

Specifications

POST, RAILS & PICKETS:	Cold Formed Steel Tubing Interior And Exterior Galvalume Coating Chromate Conversion Coating Electrostatically Applied Thermally Bonded Polyester Powder Coating Minimum Film Thickness 2.5 Mils	FITTINGS:	15 Gauge Stamp Forged Factory Finish. As Above
POSTS:	2" x 2" (51mm x 51mm) 16 Gauge Standard Post Spacing 97-1/8" (2466mm) OC.	WELDS:	Stainless Steel
POST CAP:	Pyramid, Ball or Spear	STANDARD PANEL WIDTH:	91-1/2" (2324mm)
RAILS:	1-1/4" x 1-1/4" (32mm x 32mm) 14 Gauge	AVAILABLE PANEL HEIGHTS:	48" (1219mm) (plus cap if applicable) 60" (1524mm) 72" (1828mm)
PICKETS:	5/8" x 5/8" (15mm x 15mm) 16 Gauge	NOTE:	Tamper Proof Nut Available For Brackets
		COLOURS:	Standard - High Gloss Black Optional Colours - Brown, Forest Green & Matt Black Custom Colours Available Upon Request.

<p>The following note shall apply to all drawings and associated documents:</p> <p>1. Copyright of this drawing and design is reserved by the Designer & European Wrought Iron Works Ltd. The drawing and all associated documents are an instrument of service by the Designer & European Wrought Iron Works Ltd. The drawing and the information contained therein may not be reproduced in whole or in part without prior written or verbal permission of the designer or European Wrought Iron Works Ltd.</p> <p>2. Drawings are not to be scaled for construction. All existing site conditions and dimensions required to perform the work are to be verified and any discrepancies are to be reported to the designer & European Wrought Iron Works Ltd.</p> <p>3. These drawings are not to be used for construction unless noted below as "Issued for Construction"</p> <p>4. All work to be carried out in conformance with the Code and Bylaws of the authorities having jurisdiction.</p> <p>5. The Designer of these plans and specifications gives no warranty or representation to any party about the constructability of the item represented by them.</p>	<p>CONFIDENTIAL: NOT TO BE DISCLOSED OR REPRODUCED</p> <p>EUROPEAN WROUGHT IRON WORKS</p> <p>WITHOUT THE WRITTEN PERMISSION OF EUROPEAN WROUGHT IRON WORKS LTD.</p>	<p>TOLERANCES INCHES UNLESS OTHERWISE NOTED X.XXX" ±0.005" X.XX" ±0.05" X.X" ±0.25" FRACTIONAL ±1/16" ANGULAR ±1°</p>	<p>DO NOT MODIFY OR SCALE DRAWING</p>	DRAWING & DESIGN REMAIN THE PROPERTY OF EUROPEAN WROUGHT IRON WORKS LTD.					
			PROJECT TITLE:			DESIGN:	P.D.	FINISH:	Custom
			DATE DRAWN:	June 2015	SHEET NO:	3a	DRAWING NUMBER:	RC-03a	REV
<p>TITLE: Royalty Collection Princess with Dbl. Top Rail</p>		SCALE:	NTS.	DRAWN BY:	DCM				

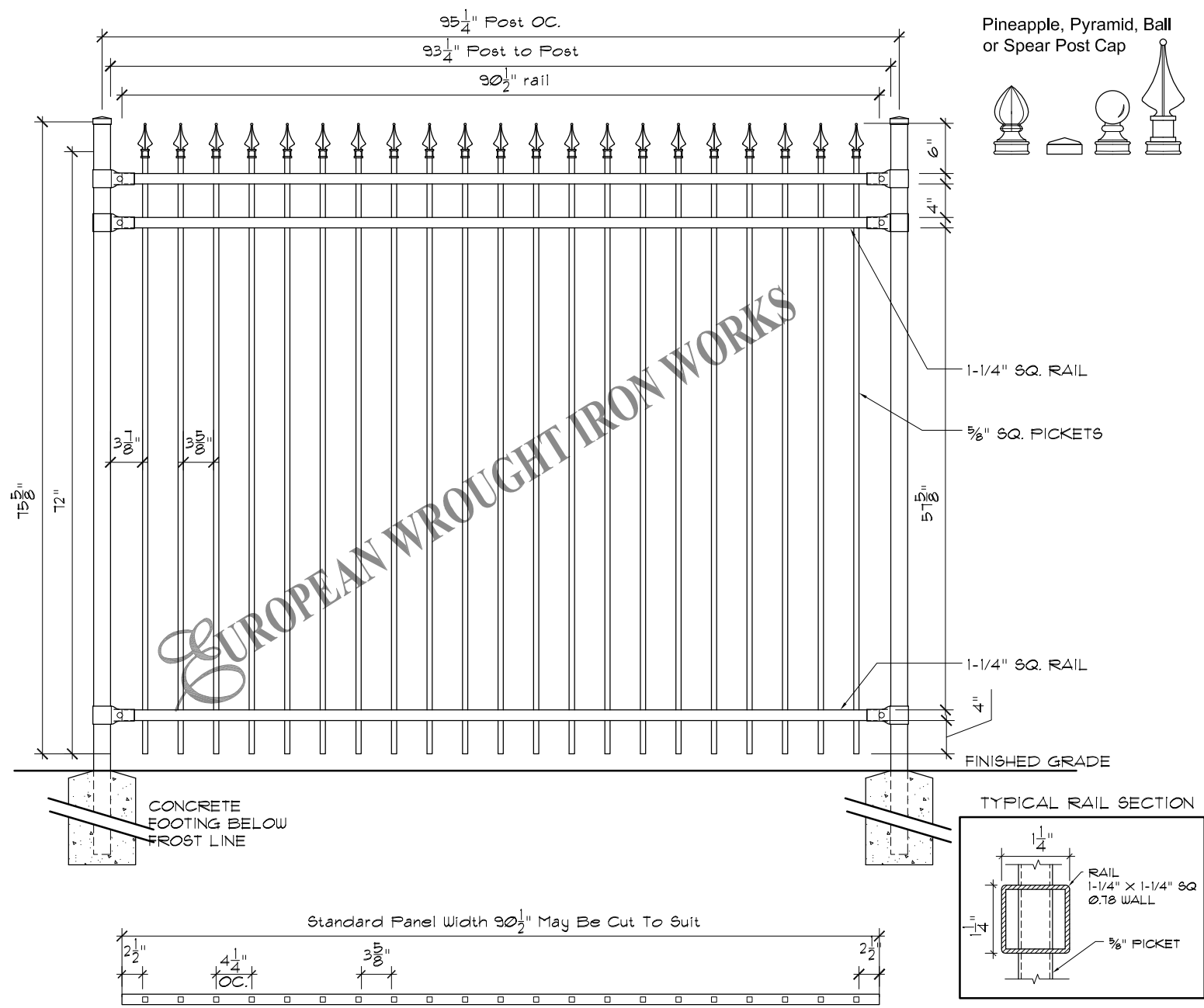

Specifications

<p>POST, RAILS & PICKETS: Cold Formed Steel Tubing Interior And Exterior Galvalume Coating Chromate Conversion Coating Electrostatically Applied Thermally Bonded Polyester Powder Coating Minimum Film Thickness 2.5 Mils</p> <p>POSTS: 2" x 2" (51mm x 51mm) 16 Gauge Standard Post Spacing 97-1/8" (2466mm) OC.</p> <p>POST CAP: Pyramid, Ball or Spear</p> <p>RAILS: 1-1/4" x 1-1/4" (32mm x 32mm) 14 Gauge</p> <p>PICKETS: 5/8" x 5/8" (15mm x 15mm) 16 Gauge</p>	<p>FITTINGS: 15 Gauge Stamp Forged Factory Finish. As Above</p> <p>WELDS: Stainless Steel</p> <p>STANDARD PANEL WIDTH: 91-1/2" (2324m)</p> <p>AVAILABLE PANEL HEIGHTS: 48" (1219mm) (plus cap if applicable) 60" (1524mm) 72" (1828mm)</p> <p>NOTE: Tamper Proof Nut Available For Brackets</p> <p>COLOURS: Standard - High Gloss Black Optional Colours - Brown, Forest Green & Matt Black Custom Colours Available Upon Request.</p>
---	--

<p>The following note shall apply to all drawings and associated documents:</p> <p>1. Copyright of this drawing and design is reserved by the Designer & European Wrought Iron Works Ltd. The drawing and all associated documents are an instrument of service by the Designer & European Wrought Iron Works Ltd. The drawing and the information contained therein may not be reproduced in whole or in part without prior written or verbal permission of the designer or European Wrought Iron Works Ltd.</p> <p>2. Drawings are not to be scaled for construction. All existing site conditions and dimensions required to perform the work are to be verified and any discrepancies are to be reported to the designer & European Wrought Iron Works Ltd.</p> <p>3. These drawings are not to be used for construction unless noted below as "Issued for Construction"</p> <p>4. All work to be carried out in conformance with the Code and Bylaws of the authorities having jurisdiction.</p> <p>5. The Designer of these plans and specifications gives no warranty or representation to any party about the constructability of the item represented by them.</p>	<p style="font-size: 8px;">CONFIDENTIAL: NOT TO BE DISCLOSED OR REPRODUCED</p> <p style="font-size: 8px;">WITHOUT THE WRITTEN PERMISSION OF EUROPEAN WROUGHT IRON WORKS LTD.</p>	<p>TOLERANCES INCHES UNLESS OTHERWISE NOTED X.XXX" ±0.005" X.XX" ±0.05" X.X" ±0.25" FRACTIONAL ±1/16" ANGULAR ±1°</p>	<p>DO NOT MODIFY OR SCALE DRAWING</p> <p>PROJECT TITLE:</p>	<p>DRAWING & DESIGN REMAIN THE PROPERTY OF EUROPEAN WROUGHT IRON WORKS LTD.</p>	<p>SCALE: NTS.</p> <p>DATE DRAWN: June 2015</p> <p>DRAWN BY: DCM</p>	<p>DESIGN: P.D.</p> <p>SHEET NO: 4a (6ft)</p>	<p>FINISH: Custom</p> <p>DRAWING NUMBER: RC-04a</p>	<p>REV 1-</p> <p>A</p>
<p>TITLE: Royalty Collection <i>Prince with Dbl. Top Rail</i></p>								

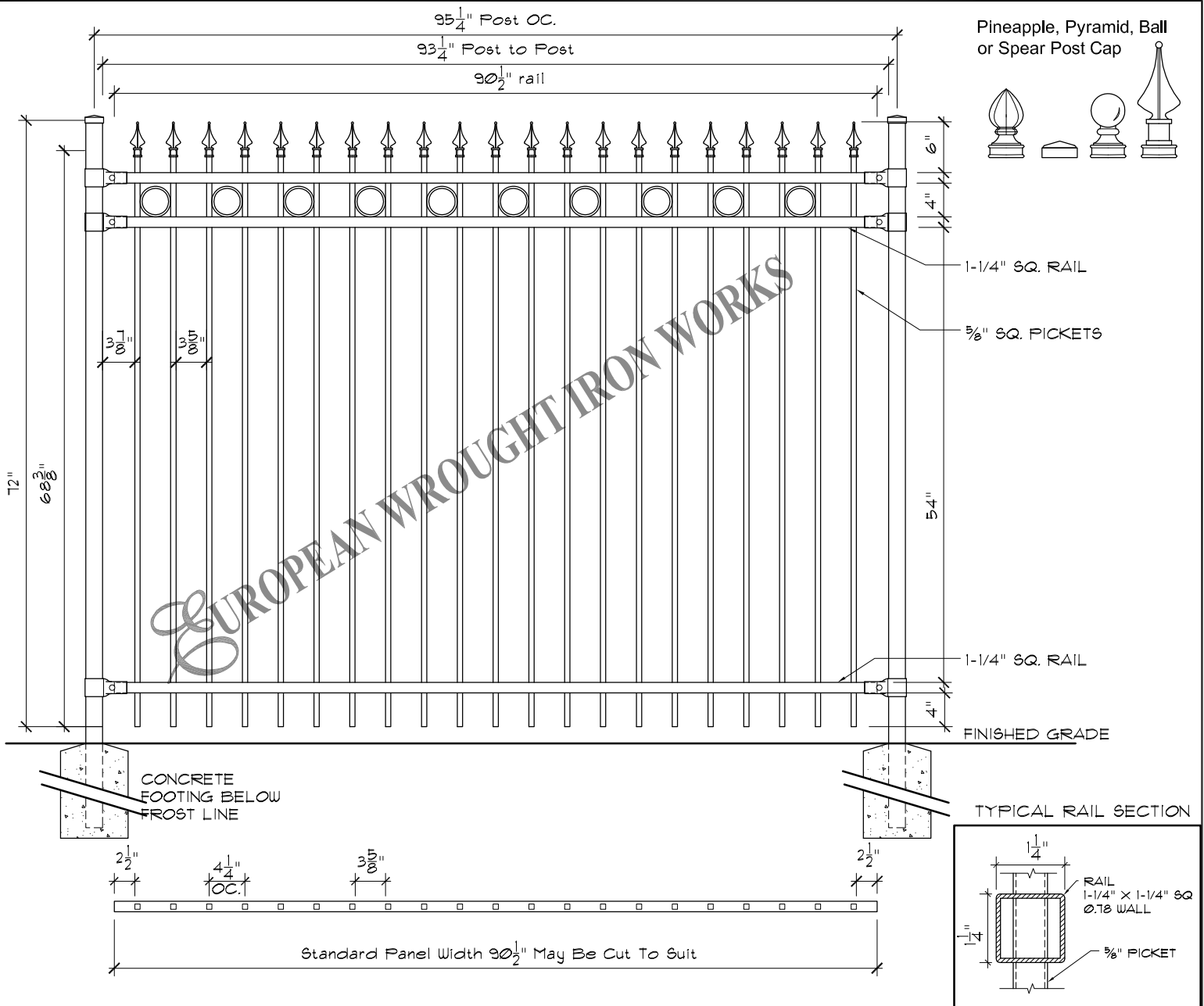

Specifications

POST, RAILS & PICKETS:	Cold Formed Steel Tubing Interior And Exterior Galvalume Coating Chromate Conversion Coating Electrostatically Applied Thermally Bonded Polyester Powder Coating Minimum Film Thickness 2.5 Mils	FITTINGS:	15 Gauge Stamp Forged Factory Finish. As Above
POSTS:	2" x 2" (51mm x 51mm) 16 Gauge Standard Post Spacing 97-1/8" (2466mm) OC.	WELDS:	Stainless Steel
POST CAP:	Pyramid, Ball or Spear	STANDARD PANEL WIDTH:	91-1/2" (2324mm)
RAILS:	1-1/4" x 1-1/4" (32mm x 32mm) 14 Gauge	AVAILABLE PANEL HEIGHTS: (plus cap if applicable)	48" (1219mm) 60" (1524mm) 72" (1828mm)
PICKETS:	5/8" x 5/8" (15mm x 15mm) 16 Gauge	NOTE:	Tamper Proof Nut Available For Brackets
		COLOURS:	Standard - High Gloss Black Optional Colours - Brown, Forest Green & Matt Black Custom Colours Available Upon Request.

The following note shall apply to all drawings and associated documents:

- Copyright of this drawing and design is reserved by the Designer & European Wrought Iron Works Ltd. The drawing and all associated documents are an instrument of service by the Designer & European Wrought Iron Works Ltd. The drawing and the information contained therein may not be reproduced in whole or in part without prior written or verbal permission of the designer or European Wrought Iron Works Ltd.
- Drawings are not to be scaled for construction. All existing site conditions and dimensions required to perform the work are to be verified and any discrepancies are to be reported to the designer & European Wrought Iron Works Ltd.
- These drawings are not to be used for construction unless noted below as "Issued for Construction"
- All work to be carried out in conformance with the Code and Bylaws of the authorities having jurisdiction.
- The Designer of these plans and specifications gives no warranty or representation to any party about the constructability of the item represented by them.

CONFIDENTIAL: NOT TO BE DISCLOSED OR REPRODUCED



TITLE: **Royalty Collection**
Prince Custom with Alt. Circle V2

TOLERANCES
INCHES
UNLESS OTHERWISE NOTED
X.XXX" ±0.005"
X.XX" ±0.05"
X.X" ±0.25"
FRACTIONAL ±1/16"
ANGULAR ±1°

SCALE: NTS.
DATE DRAWN: June 2020
DRAWN BY: DCM

DO NOT
MODIFY OR
SCALE DRAWING

PROJECT TITLE:

DRAWING & DESIGN REMAIN THE PROPERTY OF EUROPEAN WROUGHT IRON WORKS LTD.

DESIGN: P.D.
SHEET NO: 4k(ii)

FINISH: Custom
DRAWING NUMBER: RC-04k(ii)

REV 1- A

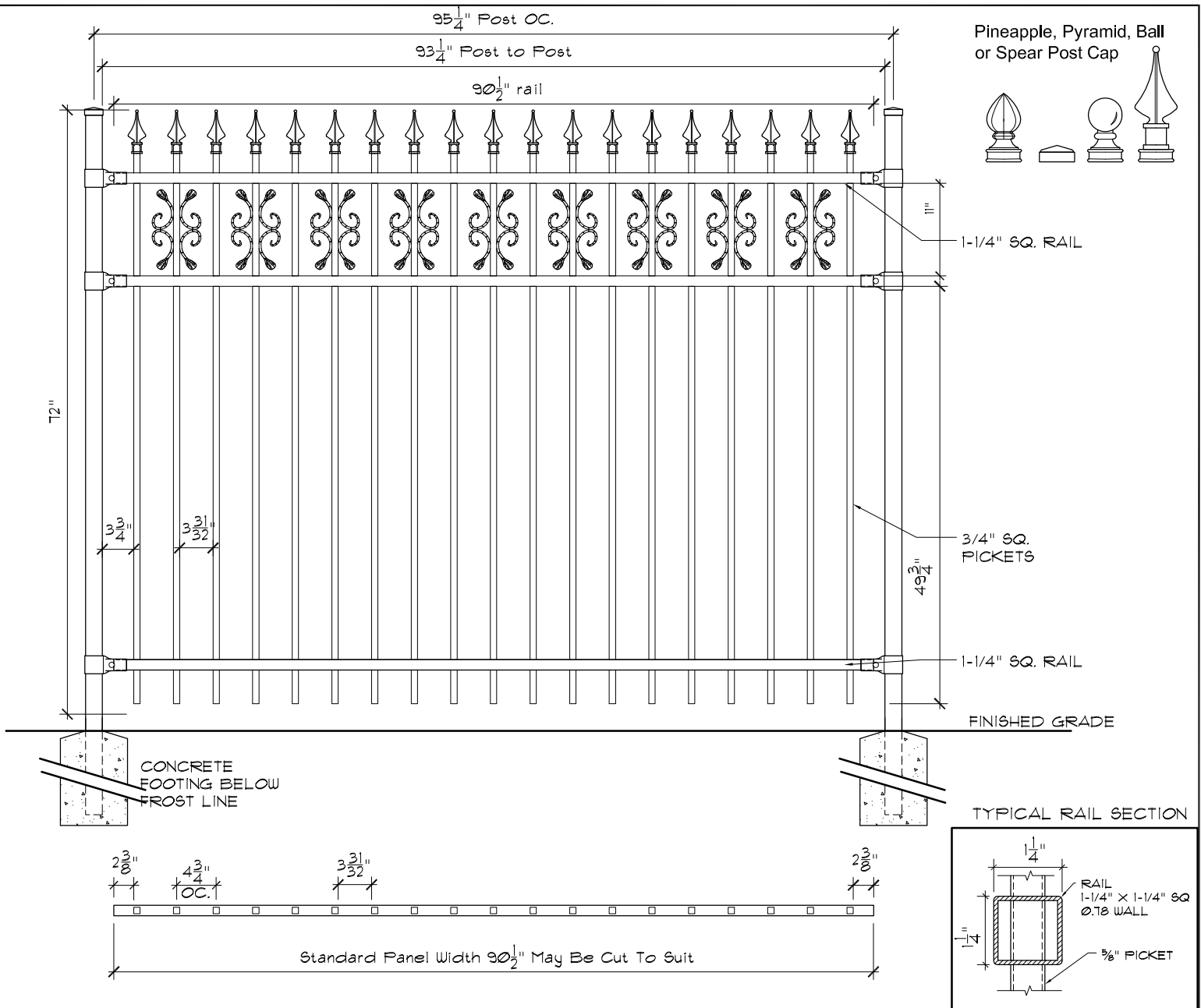

Specifications

<p>POST, RAILS & PICKETS: Cold Formed Steel Tubing Interior And Exterior Galvalume Coating Chromate Conversion Coating Electrostatically Applied Thermally Bonded Polyester Powder Coating Minimum Film Thickness 2.5 Mils</p> <p>POSTS: 2" x 2" (51mm x 51mm) 16 Gauge Standard Post Spacing 97-1/8" (2466mm) OC.</p> <p>POST CAP: Pyramid, Ball or Spear</p> <p>RAILS: 1-1/4" x 1-1/4" (32mm x 32mm) 14 Gauge</p> <p>PICKETS: 5/8" x 5/8" (15mm x 15mm) 16 Gauge</p>	<p>FITTINGS: 15 Gauge Stamp Forged Factory Finish. As Above</p> <p>WELDS: Stainless Steel</p> <p>STANDARD PANEL WIDTH: 91-1/2" (2324mm)</p> <p>AVAILABLE PANEL HEIGHTS: 48" (1219mm) (plus cap if applicable) 60" (1524mm) 72" (1828mm)</p> <p>NOTE: Tamper Proof Nut Available For Brackets</p> <p>COLOURS: Standard - High Gloss Black Optional Colours - Brown, Forest Green & Matt Black Custom Colours Available Upon Request.</p>
---	---

The following note shall apply to all drawings and associated documents:

- Copyright of this drawing and design is reserved by the Designer & European Wrought Iron Works Ltd. The drawing and all associated documents are an instrument of service by the Designer & European Wrought Iron Works Ltd. The drawing and the information contained therein may not be reproduced in whole or in part without prior written or verbal permission of the designer or European Wrought Iron Works Ltd.
- Drawings are not to be scaled for construction. All existing site conditions and dimensions required to perform the work are to be verified and any discrepancies are to be reported to the designer & European Wrought Iron Works Ltd.
- These drawings are not to be used for construction unless noted below as "Issued for Construction"
- All work to be carried out in conformance with the Code and Bylaws of the authorities having jurisdiction.
- The Designer of these plans and specifications gives no warranty or representation to any party about the constructability of the item represented by them.

CONFIDENTIAL: NOT TO BE DISCLOSED OR REPRODUCED

EUROPEAN
WROUGHT IRON WORKS

WITHOUT THE WRITTEN PERMISSION OF EUROPEAN WROUGHT IRON WORKS LTD.

TITLE: **Royalty Collection**
3/4" Prince

TOLERANCES INCHES UNLESS OTHERWISE NOTED
X.XXX" ±0.005"
X.XX" ±0.05"
X.X" ±0.25"
FRACTIONAL ±1/16"
ANGULAR ±1°

SCALE: NTS.

DATE DRAWN: Aug 2017

DRAWN BY: DCM

DO NOT MODIFY OR SCALE DRAWING

PROJECT TITLE:

DESIGN: P.D.

SHEET NO: 12sc3

DRAWING & DESIGN REMAIN THE PROPERTY OF EUROPEAN WROUGHT IRON WORKS LTD.

FINISH: Custom

DRAWING NUMBER: RC-12

REV 1- A

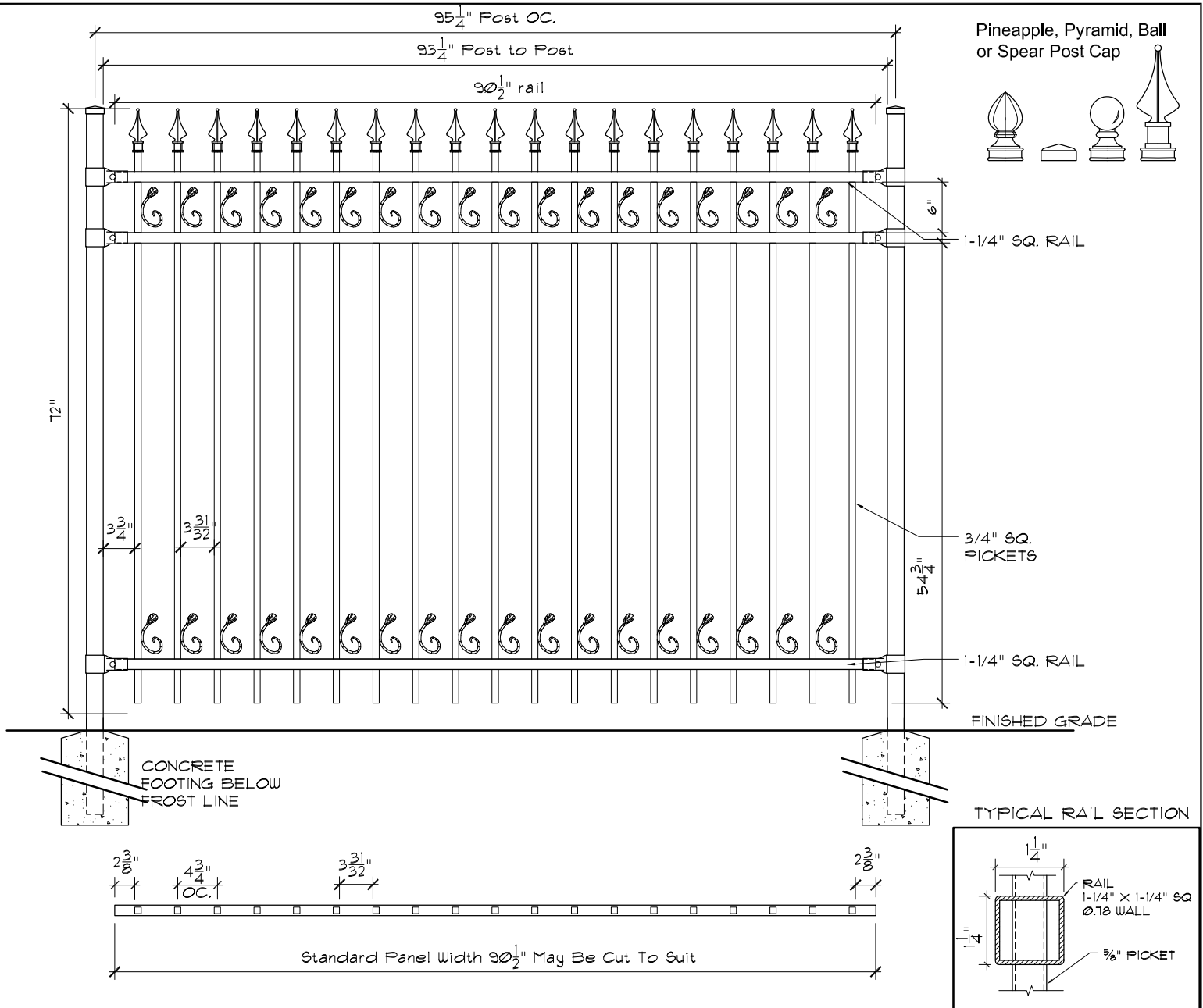

Specifications

POST, RAILS & PICKETS: Cold Formed Steel Tubing
Interior And Exterior Galvalume Coating
Chromate Conversion Coating
Electrostatically Applied
Thermally Bonded Polyester Powder Coating
Minimum Film Thickness 2.5 Mills

POSTS: 2" x 2" (51mm x 51mm) 16 Gauge
Standard Post Spacing 97-1/8" (2466mm) OC.

POST CAP: Pyramid, Ball or Spear

RAILS: 1-1/4" x 1-1/4" (32mm x 32mm) 14 Gauge

PICKETS: 5/8" x 5/8" (15mm x 15mm) 16 Gauge

FITTINGS: 15 Gauge Stamp Forged Factory Finish. As Above

WELDS: Stainless Steel

STANDARD PANEL WIDTH: 91-1/2" (2324mm)

AVAILABLE PANEL HEIGHTS: 48" (1219mm)
(plus cap if applicable) 60" (1524mm)
72" (1828mm)

NOTE: Tamper Proof Nut Available For Brackets

COLOURS: Standard - High Gloss Black
Optional Colours - Brown, Forest Green & Matt Black
Custom Colours Available Upon Request.

The following note shall apply to all drawings and associated documents:

- Copyright of this drawing and design is reserved by the Designer & European Wrought Iron Works Ltd. The drawing and all associated documents are an instrument of service by the Designer & European Wrought Iron Works Ltd. The drawing and the information contained therein may not be reproduced in whole or in part without prior written or verbal permission of the designer or European Wrought Iron Works Ltd.
- Drawings are not to be scaled for construction. All existing site conditions and dimensions required to perform the work are to be verified and any discrepancies are to be reported to the designer & European Wrought Iron Works Ltd.
- These drawings are not to be used for construction unless noted below as "Issued for Construction"
- All work to be carried out in conformance with the Code and Bylaws of the authorities having jurisdiction.
- The Designer of these plans and specifications gives no warranty or representation to any party about the constructability of the item represented by them.

CONFIDENTIAL: NOT TO BE DISCLOSED OR REPRODUCED



TITLE:
Royalty Collection
3/4" Prince

TOLERANCES
INCHES
UNLESS OTHERWISE NOTED
X.XXX" ±0.005"
X.XX" ±0.05"
X.X" ±0.25"
FRACTIONAL ±1/16"
ANGULAR ±1°

SCALE: NTS.
DATE DRAWN: Aug 2017
DRAWN BY: DCM

DO NOT
MODIFY OR
SCALE DRAWING

DRAWING & DESIGN REMAIN THE PROPERTY OF EUROPEAN WROUGHT IRON WORKS LTD.

PROJECT TITLE:

DESIGN: P.D.

FINISH: Custom

SHEET NO: 12sc4

DRAWING NUMBER: RC-12

REV
1- A

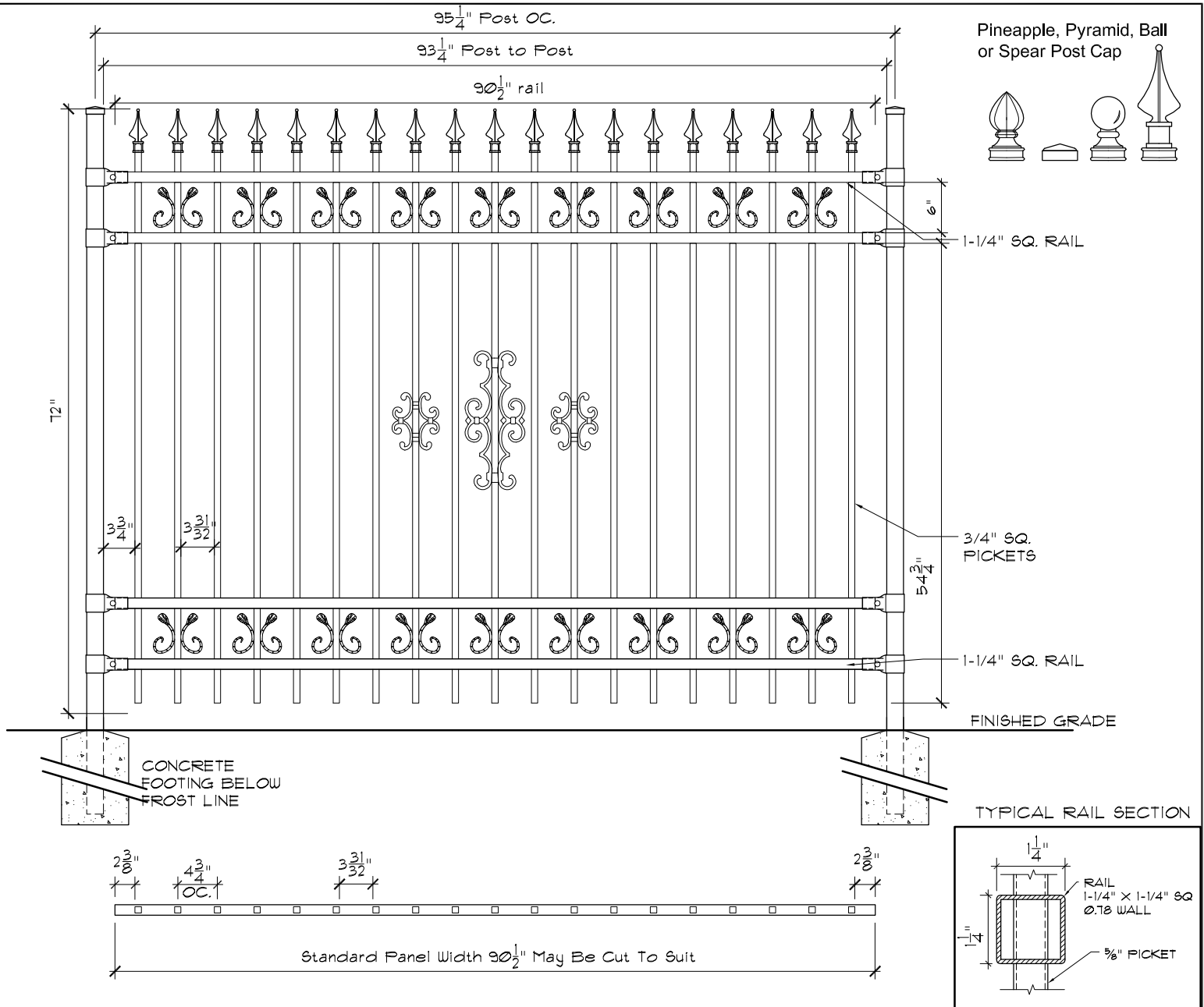

Specifications

<p>POST, RAILS & PICKETS: Cold Formed Steel Tubing Interior And Exterior Galvalume Coating Chromate Conversion Coating Electrostatically Applied Thermally Bonded Polyester Powder Coating Minimum Film Thickness 2.5 Mils</p> <p>POSTS: 2" x 2" (51mm x 51mm) 16 Gauge Standard Post Spacing 97-1/8" (2466mm) OC.</p> <p>POST CAP: Pyramid, Ball or Spear</p> <p>RAILS: 1-1/4" x 1-1/4" (32mm x 32mm) 14 Gauge</p> <p>PICKETS: 5/8" x 5/8" (15mm x 15mm) 16 Gauge</p>	<p>FITTINGS: 15 Gauge Stamp Forged Factory Finish. As Above</p> <p>WELDS: Stainless Steel</p> <p>STANDARD PANEL WIDTH: 91-1/2" (2324mm)</p> <p>AVAILABLE PANEL HEIGHTS: 48" (1219mm) (plus cap if applicable) 60" (1524mm) 72" (1828mm)</p> <p>NOTE: Tamper Proof Nut Available For Brackets</p> <p>COLOURS: Standard - High Gloss Black Optional Colours - Brown, Forest Green & Matt Black Custom Colours Available Upon Request.</p>
---	---

The following note shall apply to all drawings and associated documents:
 1. Copyright of this drawing and design is reserved by the Designer & European Wrought Iron Works Ltd. The drawing and all associated documents are an instrument of service by the Designer & European Wrought Iron Works Ltd. The drawing and the information contained therein may not be reproduced in whole or in part without prior written or verbal permission of the designer or European Wrought Iron Works Ltd.
 2. Drawings are not to be scaled for construction. All existing site conditions and dimensions required to perform the work are to be verified and any discrepancies are to be reported to the designer & European Wrought Iron Works Ltd.
 3. These drawings are not to be used for construction unless noted below as "Issued for Construction"
 4. All work to be carried out in conformance with the Code and Bylaws of the authorities having jurisdiction.
 5. The Designer of these plans and specifications gives no warranty or representation to any party about the constructability of the item represented by them.

CONFIDENTIAL: NOT TO BE DISCLOSED OR REPRODUCED

EUROPEAN
WROUGHT IRON WORKS
WITHOUT THE WRITTEN PERMISSION OF EUROPEAN WROUGHT IRON WORKS LTD.

TITLE:
Royalty Collection
3/4" Prince w. Center Scroll

TOLERANCES INCHES UNLESS OTHERWISE NOTED X.XXX" ±0.005" X.XX" ±0.05" X.X" ±0.25" FRACTIONAL ±1/16" ANGULAR ±1°	SCALE: NTS.	DATE DRAWN: Aug 2017	DRAWN BY: DCM
--	--------------------	-----------------------------	----------------------

DO NOT MODIFY OR SCALE DRAWING	PROJECT TITLE:
DESIGN: P.D.	FINISH: Custom
SHEET NO: 12sc5	DRAWING NUMBER: RC-12

DRAWING & DESIGN REMAIN THE PROPERTY OF EUROPEAN WROUGHT IRON WORKS LTD.	
REV	A

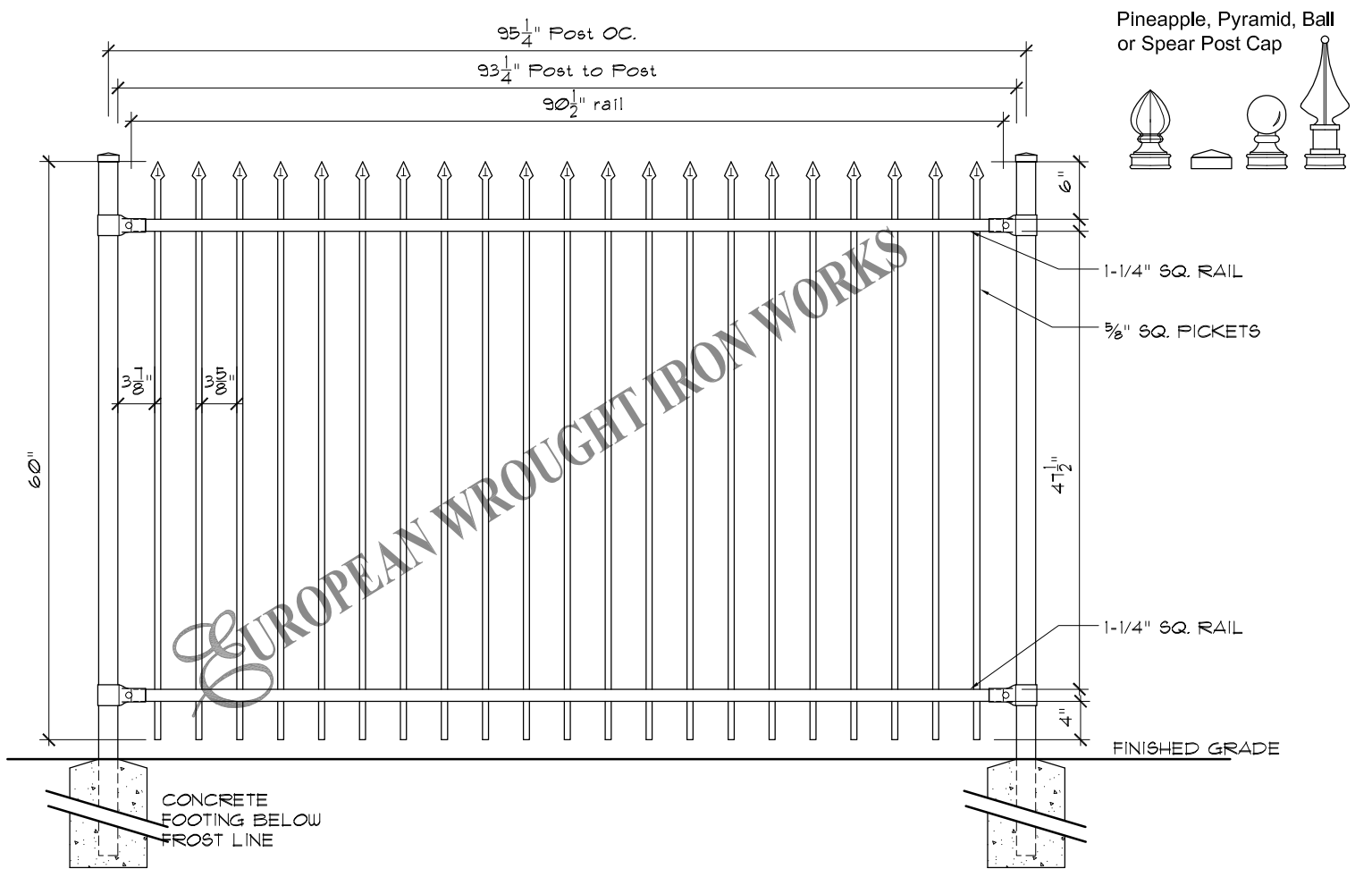

EUROPEAN WROUGHT IRON WORKS

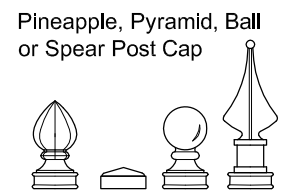

1-1/4" SQ. RAIL
5/8" SQ. PICKETS

1-1/4" SQ. RAIL
FINISHED GRADE

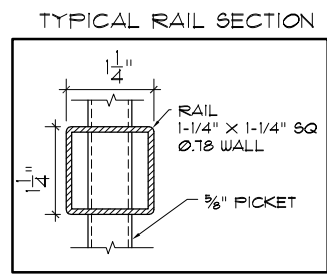
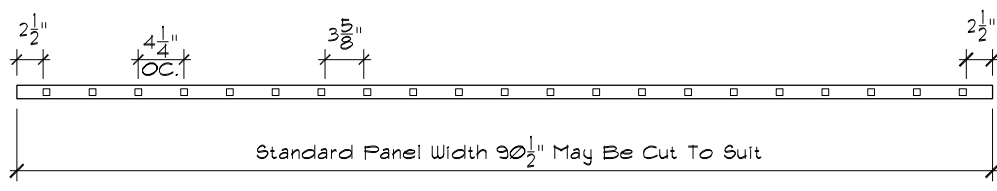

Specifications

<p>POST, RAILS & PICKETS: Cold Formed Steel Tubing Interior And Exterior Galvalume Coating Chromate Conversion Coating Electrostatically Applied Thermally Bonded Polyester Powder Coating Minimum Film Thickness 2.5 MILS</p> <p>POSTS: 2" x 2" (51mm x 51mm) 16 Gauge Standard Post Spacing 97-1/8" (2466mm) OC.</p> <p>POST CAP: Pyramid, Ball or Spear</p> <p>RAILS: 1-1/4" x 1-1/4" (32mm x 32mm) 14 Gauge</p> <p>PICKETS: 5/8" x 5/8" (15mm x 15mm) 16 Gauge</p>	<p>FITTINGS: 15 Gauge Stamp Forged Factory Finish. As Above</p> <p>WELDS: Stainless Steel</p> <p>STANDARD PANEL WIDTH: 91-1/2" (2324mm)</p> <p>AVAILABLE PANEL HEIGHTS: 48" (1219mm) (plus cap if applicable) 60" (1524mm) 72" (1828mm)</p> <p>NOTE: Tamper Proof Nut Available For Brackets</p> <p>COLOURS: Standard - High Gloss Black Optional Colours - Brown, Forest Green & Matt Black Custom Colours Available Upon Request.</p>
---	---

<p>The following note shall apply to all drawings and associated documents:</p> <p>1. Copyright of this drawing and design is reserved by the Designer & European Wrought Iron Works Ltd. The drawing and all associated documents are an instrument of service by the Designer & European Wrought Iron Works Ltd. The drawing and the information contained therein may not be reproduced in whole or in part without prior written or verbal permission of the designer or European Wrought Iron Works Ltd.</p> <p>2. Drawings are not to be scaled for construction. All existing site conditions and dimensions required to perform the work are to be verified and any discrepancies are to be reported to the designer & European Wrought Iron Works Ltd.</p> <p>3. These drawings are not to be used for construction unless noted below as "Issued for Construction"</p> <p>4. All work to be carried out in conformance with the Code and Bylaws of the authorities having jurisdiction.</p> <p>5. The Designer of these plans and specifications gives no warranty or representation to any party about the constructability of the item represented by them.</p>	<p style="font-size: 8px;">CONFIDENTIAL: NOT TO BE DISCLOSED OR REPRODUCED</p> <p style="font-size: 8px;">WITHOUT THE WRITTEN PERMISSION OF EUROPEAN WROUGHT IRON WORKS LTD.</p>	<p>TOLERANCES INCHES UNLESS OTHERWISE NOTED</p> <p>X.XXX" ±0.005" X.XX" ±0.05" X.X" ±0.25" FRACTIONAL ±1/16" ANGULAR ±1°</p>	<p>DO NOT MODIFY OR SCALE DRAWING</p> <p>PROJECT TITLE:</p>	<p>DRAWING & DESIGN REMAIN THE PROPERTY OF EUROPEAN WROUGHT IRON WORKS LTD.</p>		
<p>TITLE: Royalty Collection Princess</p>	<p>SCALE: NTS.</p> <p>DATE DRAWN: June 2015</p> <p>DRAWN BY: DCM</p>	<p>DESIGN: P.D.</p> <p>SHEET NO: 3</p>	<p>FINISH: Custom</p> <p>DRAWING NUMBER: RC-03</p>	<p>REV: 1-</p> <p>A</p>		

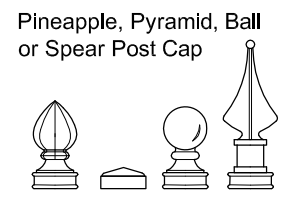
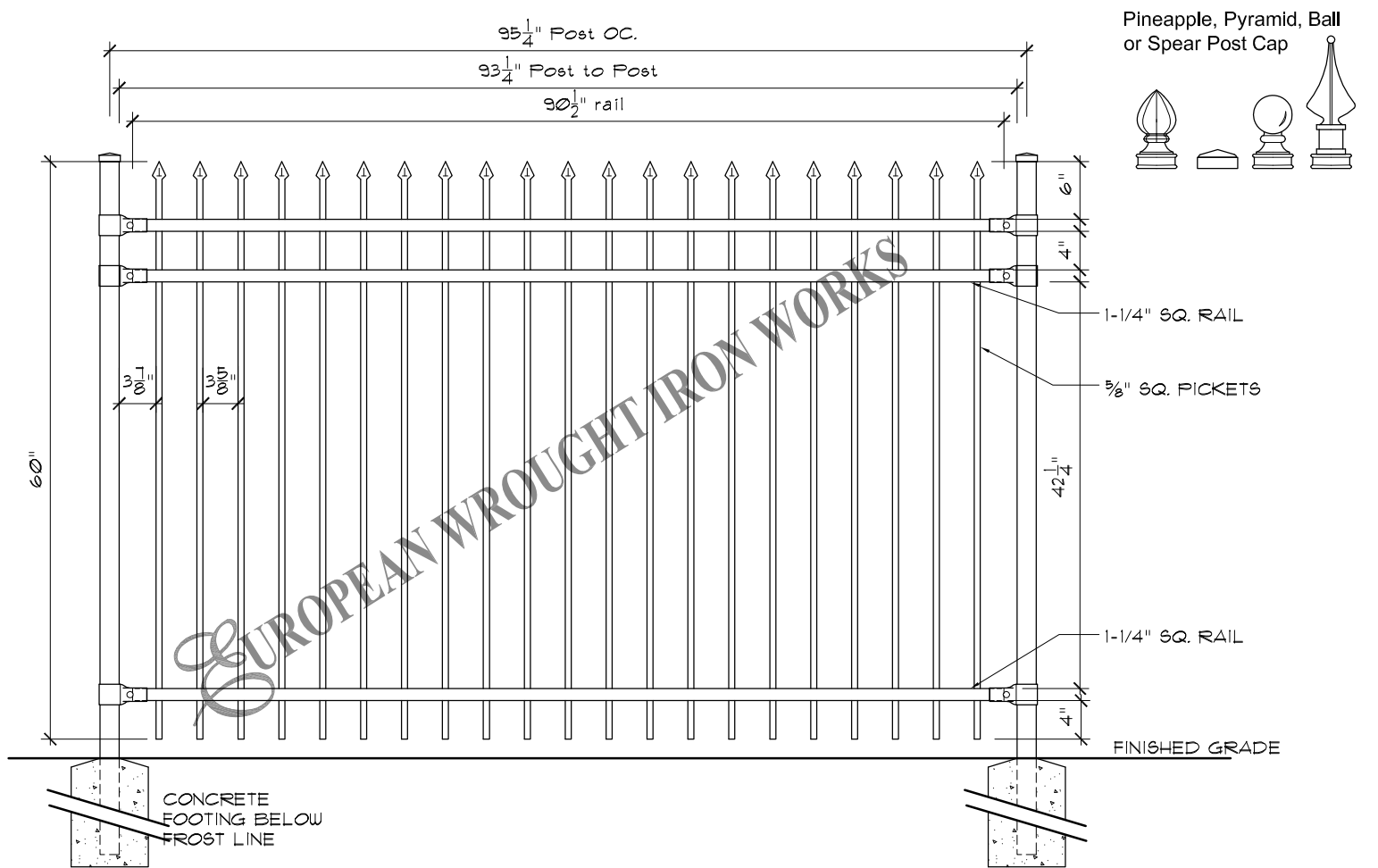

EUROPEAN WROUGHT IRON WORKS

1-1/4" SQ. RAIL
 5/8" SQ. PICKETS
 1-1/4" SQ. RAIL
 FINISHED GRADE

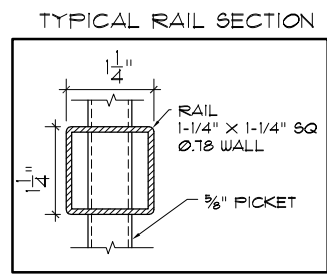
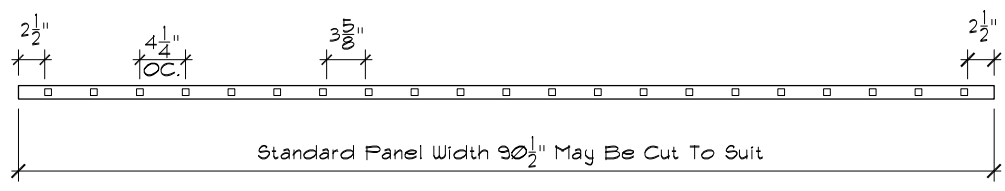

Specifications

<p>POST, RAILS & PICKETS: Cold Formed Steel Tubing Interior And Exterior Galvalume Coating Chromate Conversion Coating Electrostatically Applied Thermally Bonded Polyester Powder Coating Minimum Film Thickness 2.5 Mils</p> <p>POSTS: 2" x 2" (51mm x 51mm) 16 Gauge Standard Post Spacing 97-1/8" (2466mm) OC.</p> <p>POST CAP: Pyramid, Ball or Spear</p> <p>RAILS: 1-1/4" x 1-1/4" (32mm x 32mm) 14 Gauge</p> <p>PICKETS: 5/8" x 5/8" (15mm x 15mm) 16 Gauge</p>	<p>FITTINGS: 15 Gauge Stamp Forged Factory Finish. As Above</p> <p>WELDS: Stainless Steel</p> <p>STANDARD PANEL WIDTH: 91-1/2" (2324mm)</p> <p>AVAILABLE PANEL HEIGHTS: 48" (1219mm) (plus cap if applicable) 60" (1524mm) 72" (1828mm)</p> <p>NOTE: Tamper Proof Nut Available For Brackets</p> <p>COLOURS: Standard - High Gloss Black Optional Colours - Brown, Forest Green & Matt Black Custom Colours Available Upon Request.</p>
---	---

<p>The following note shall apply to all drawings and associated documents:</p> <p>1. Copyright of this drawing and design is reserved by the Designer & European Wrought Iron Works Ltd. The drawing and all associated documents are an instrument of service by the Designer & European Wrought Iron Works Ltd. The drawing and the information contained therein may not be reproduced in whole or in part without prior written or verbal permission of the designer or European Wrought Iron Works Ltd.</p> <p>2. Drawings are not to be scaled for construction. All existing site conditions and dimensions required to perform the work are to be verified and any discrepancies are to be reported to the designer & European Wrought Iron Works Ltd.</p> <p>3. These drawings are not to be used for construction unless noted below as "Issued for Construction"</p> <p>4. All work to be carried out in conformance with the Code and Bylaws of the authorities having jurisdiction.</p> <p>5. The Designer of these plans and specifications gives no warranty or representation to any party about the constructability of the item represented by them.</p>	<p style="font-size: 8px;">CONFIDENTIAL: NOT TO BE DISCLOSED OR REPRODUCED</p> <p style="font-size: 8px;">WITHOUT THE WRITTEN PERMISSION OF EUROPEAN WROUGHT IRON WORKS LTD.</p>	<p>TOLERANCES INCHES UNLESS OTHERWISE NOTED X.XXX" ±0.005" X.XX" ±0.05" X.X" ±0.25" FRACTIONAL ±1/16" ANGULAR ±1°</p>	<p>DO NOT MODIFY OR SCALE DRAWING</p> <p>PROJECT TITLE:</p>	<p>DRAWING & DESIGN REMAIN THE PROPERTY OF EUROPEAN WROUGHT IRON WORKS LTD.</p>		
<p>TITLE: Royalty Collection Princess with Dbl. Top Rail</p>	<p>SCALE: NTS.</p> <p>DATE DRAWN: June 2015</p> <p>DRAWN BY: DCM</p>	<p>DESIGN: P.D.</p> <p>SHEET NO: 3a</p>	<p>FINISH: Custom</p> <p>DRAWING NUMBER: RC-03a</p>	<p>REV: 1-</p> <p style="font-size: 1.5em; font-weight: bold;">A</p>		

Pineapple, Pyramid, Ball or Spear Post Cap

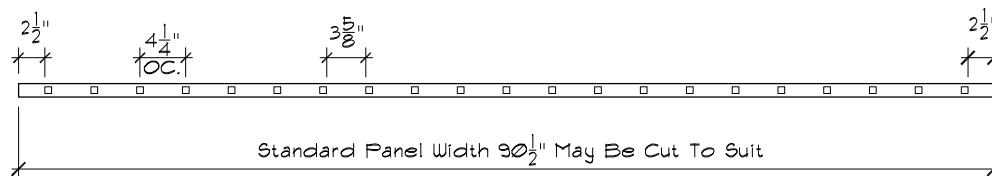
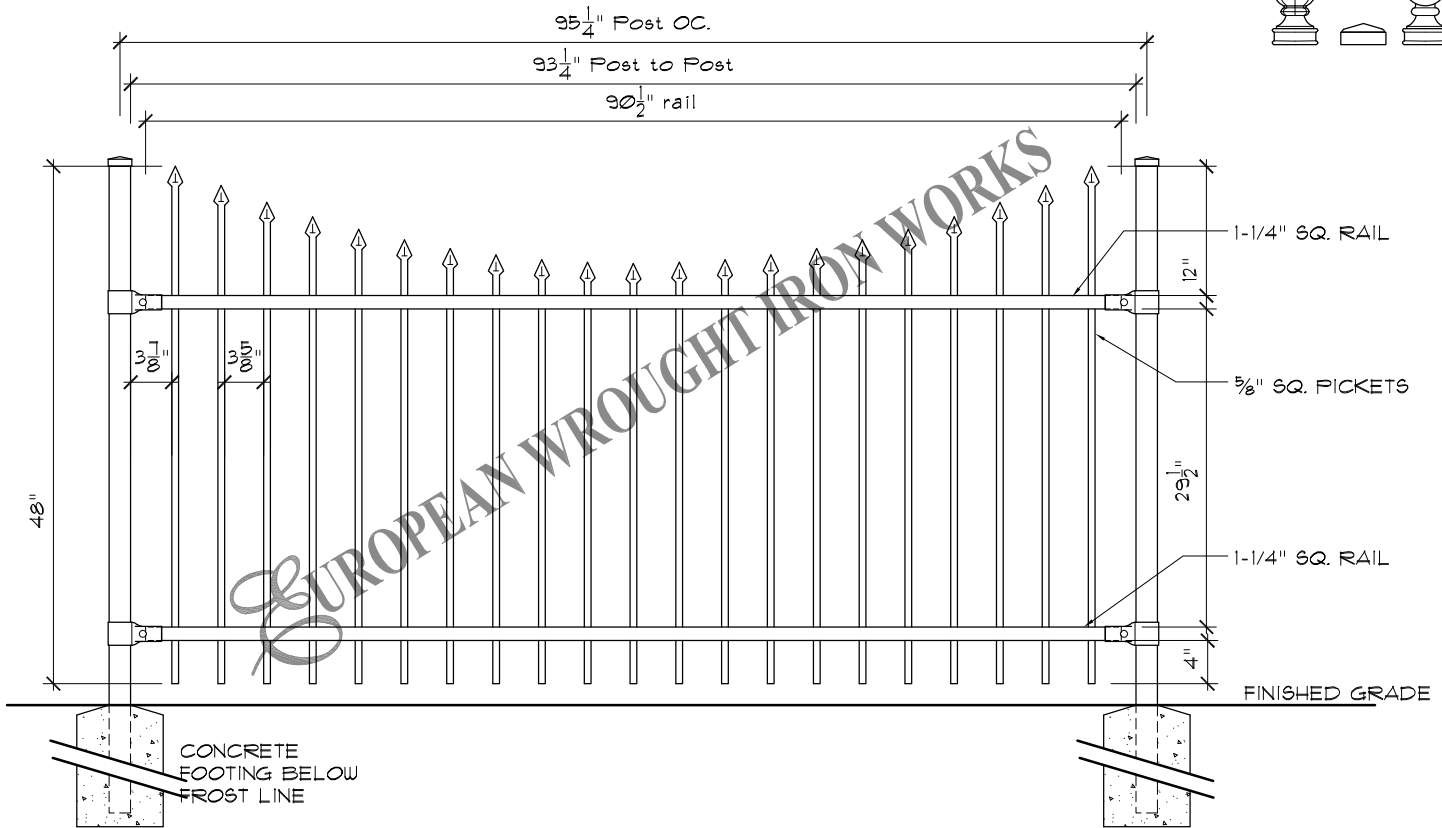
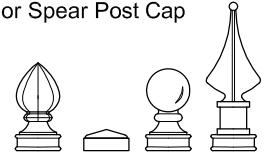

TYPICAL RAIL SECTION

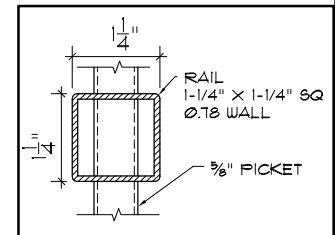

Specifications

POST, RAILS & PICKETS:	Cold Formed Steel Tubing Interior And Exterior Galvalume Coating Chromate Conversion Coating Electrostatically Applied Thermally Bonded Polyester Powder Coating Minimum Film Thickness 2.5 Mills	FITTINGS:	15 Gauge Stamp Forged Factory Finish. As Above
POSTS:	2" x 2" (51mm x 51mm) 16 Gauge Standard Post Spacing 97-1/8" (2466mm) OC.	WELDS:	Stainless Steel
POST CAP:	Pyramid, Ball or Spear	STANDARD PANEL WIDTH:	91-1/2" (2324mm)
RAILS:	1-1/4" x 1-1/4" (32mm x 32mm) 14 Gauge	AVAILABLE PANEL HEIGHTS:	48" (1219mm) (plus cap if applicable) 60" (1524mm) 72" (1828mm)
PICKETS:	5/8" x 5/8" (15mm x 15mm) 16 Gauge	NOTE:	Tamper Proof Nut Available For Brackets
		COLOURS:	Standard - High Gloss Black Optional Colours - Brown, Forest Green & Matt Black Custom Colours Available Upon Request.

The following note shall apply to all drawings and associated documents:
 1. Copyright of this drawing and design is reserved by the Designer & European Wrought Iron Works Ltd. The drawing and all associated documents are an instrument of service by the Designer & European Wrought Iron Works Ltd. The drawing and the information contained therein may not be reproduced in whole or in part without prior written or verbal permission of the designer or European Wrought Iron Works Ltd.
 2. Drawings are not to be scaled for construction. All existing site conditions and dimensions required to perform the work are to be verified and any discrepancies are to be reported to the designer & European Wrought Iron Works Ltd.
 3. These drawings are not to be used for construction unless noted below as "Issued for Construction"
 4. All work to be carried out in conformance with the Code and Bylaws of the authorities having jurisdiction.
 5. The Designer of these plans and specifications gives no warranty or representation to any party about the constructability of the item represented by them.

CONFIDENTIAL: NOT TO BE DISCLOSED OR REPRODUCED

EUROPEAN
WROUGHT IRON WORKS
WITHOUT THE WRITTEN PERMISSION OF EUROPEAN WROUGHT IRON WORKS LTD.

TITLE:
Royalty Collection
Princess with Scallop Top

TOLERANCES INCHES UNLESS OTHERWISE NOTED X.XXX" ±0.005" X.XX" ±0.05" X.X" ±0.25" FRACTIONAL ±1/16" ANGULAR ±1°	SCALE: NTS.	DATE DRAWN: June 2015	DRAWN BY: DCM
--	-----------------------	---------------------------------	-------------------------

DO NOT MODIFY OR SCALE DRAWING	PROJECT TITLE:
DESIGN: P.D.	FINISH: Custom
SHEET NO: 3b	DRAWING NUMBER: RC-03b

DRAWING & DESIGN REMAIN THE PROPERTY OF EUROPEAN WROUGHT IRON WORKS LTD.	
REV	A

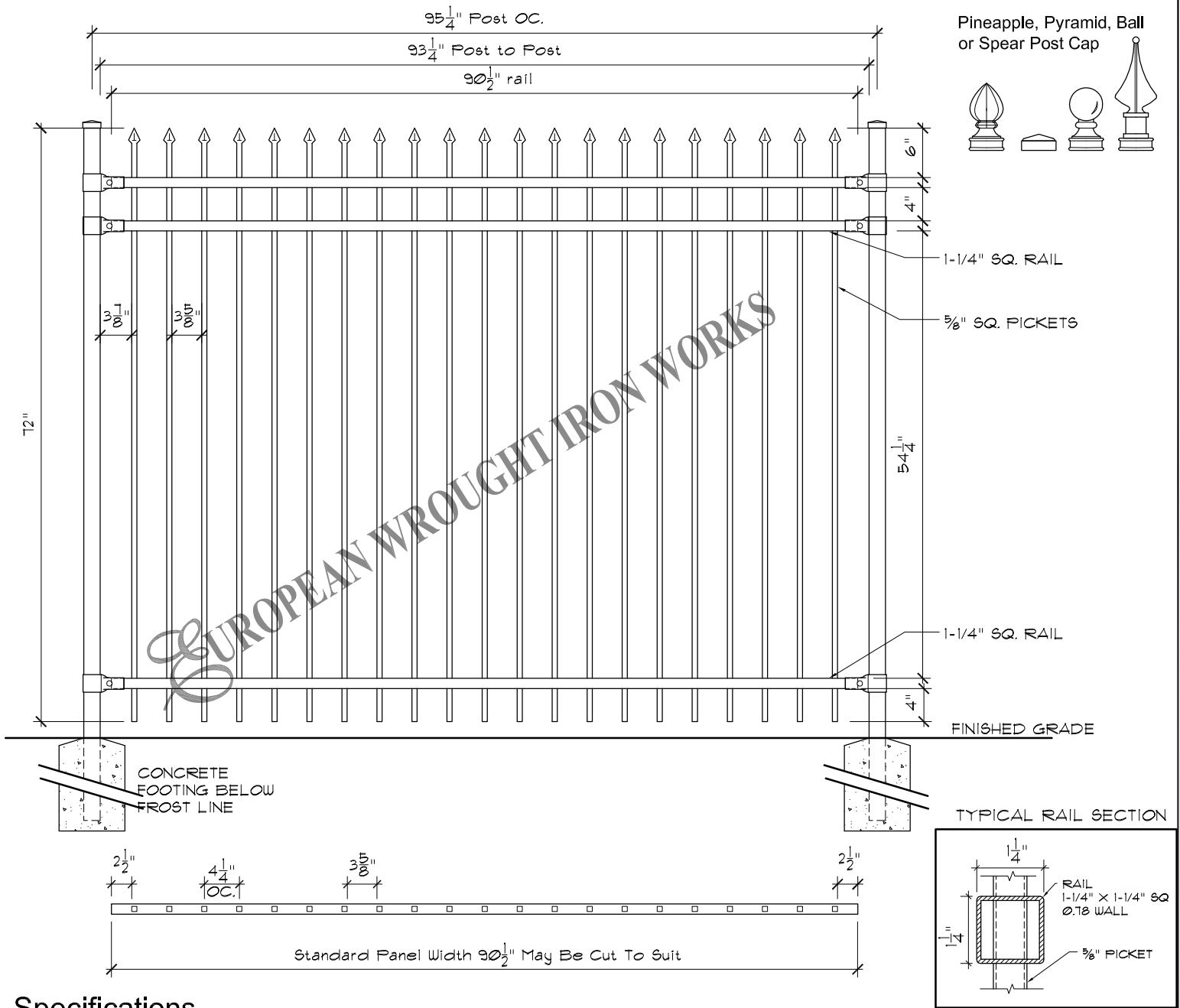

Specifications

POST, RAILS & PICKETS:	Cold Formed Steel Tubing Interior And Exterior Galvalume Coating Chromate Conversion Coating Electrostatically Applied Thermally Bonded Polyester Powder Coating Minimum Film Thickness 2.5 Mils	FITTINGS:	15 Gauge Stamp Forged Factory Finish. As Above
POSTS:	2" x 2" (51mm x 51mm) 16 Gauge Standard Post Spacing 97-1/8" (2466mm) OC.	WELDS:	Stainless Steel
POST CAP:	Pyramid, Ball or Spear	STANDARD PANEL WIDTH:	91-1/2" (2324mm)
RAILS:	1-1/4" x 1-1/4" (32mm x 32mm) 14 Gauge	AVAILABLE PANEL HEIGHTS:	48" (1219mm) (plus cap if applicable) 60" (1524mm) 72" (1828mm)
PICKETS:	5/8" x 5/8" (15mm x 15mm) 16 Gauge	NOTE:	Tamper Proof Nut Available For Brackets
		COLOURS:	Standard - High Gloss Black Optional Colours - Brown, Forest Green & Matt Black Custom Colours Available Upon Request.

The following note shall apply to all drawings and associated documents:

- Copyright of this drawing and design is reserved by the Designer & European Wrought Iron Works Ltd. The drawing and all associated documents are an instrument of service by the Designer & European Wrought Iron Works Ltd. The drawing and the information contained therein may not be reproduced in whole or in part without prior written or verbal permission of the designer or European Wrought Iron Works Ltd.
- Drawings are not to be scaled for construction. All existing site conditions and dimensions required to perform the work are to be verified and any discrepancies are to be reported to the designer & European Wrought Iron Works Ltd.
- These drawings are not to be used for construction unless noted below as "Issued for Construction"
- All work to be carried out in conformance with the Code and Bylaws of the authorities having jurisdiction.
- The Designer of these plans and specifications gives no warranty or representation to any party about the constructability of the item represented by them.

CONFIDENTIAL: NOT TO BE DISCLOSED OR REPRODUCED



TITLE: **Royalty Collection**
Princess with Dbl. Top Rail

TOLERANCES INCHES
UNLESS OTHERWISE NOTED
X.XXX" ±0.005"
X.XX" ±0.05"
X.X" ±0.25"
FRACTIONAL ±1/16"
ANGULAR ±1°

SCALE: NTS.
DATE DRAWN: June 2015
DRAWN BY: DCM

DO NOT MODIFY OR SCALE DRAWING

PROJECT TITLE:
DESIGN: P.D.
SHEET NO: 3a

DRAWING & DESIGN REMAIN THE PROPERTY OF EUROPEAN WROUGHT IRON WORKS LTD.

FINISH: Custom
DRAWING NUMBER: RC-03c
REV: 1- A

Pineapple, Pyramid, Ball or Spear Post Cap

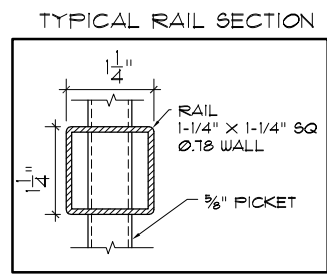
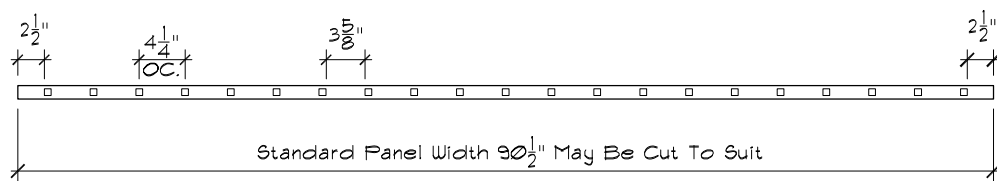
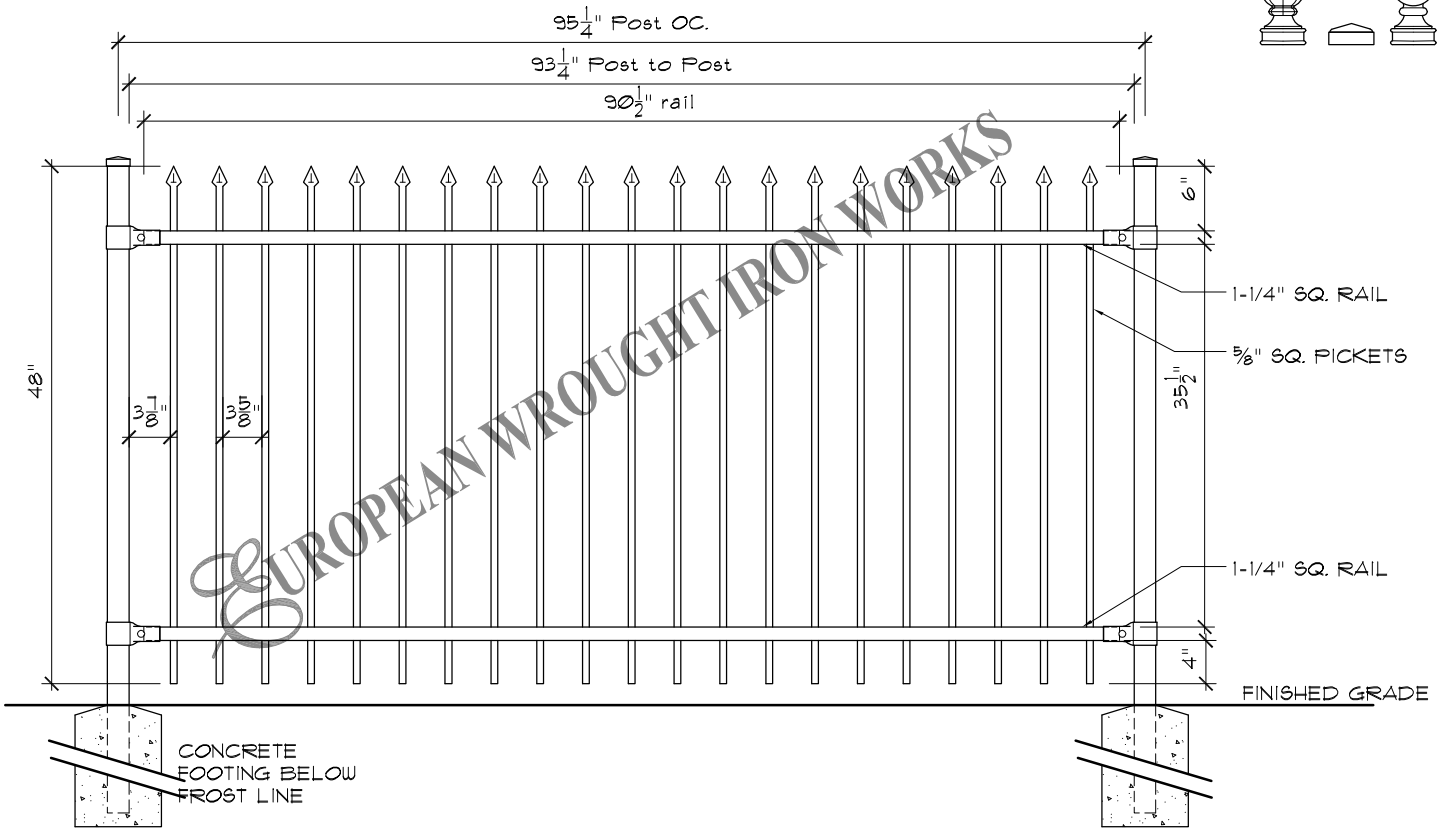
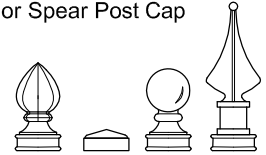

Specifications

POST, RAILS & PICKETS:	Cold Formed Steel Tubing Interior And Exterior Galvalume Coating Chromate Conversion Coating Electrostatically Applied Thermally Bonded Polyester Powder Coating Minimum Film Thickness 2.5 MILS	FITTINGS:	15 Gauge Stamp Forged Factory Finish. As Above
POSTS:	2" x 2" (51mm x 51mm) 16 Gauge Standard Post Spacing 97-1/8" (2466mm) OC.	WELDS:	Stainless Steel
POST CAP:	Pyramid, Ball or Spear	STANDARD PANEL WIDTH:	91-1/2" (2324mm)
RAILS:	1-1/4" x 1-1/4" (32mm x 32mm) 14 Gauge	AVAILABLE PANEL HEIGHTS:	48" (1219mm) (plus cap if applicable) 60" (1524mm) 72" (1828mm)
PICKETS:	5/8" x 5/8" (15mm x 15mm) 16 Gauge	NOTE:	Tamper Proof Nut Available For Brackets
		COLOURS:	Standard - High Gloss Black Optional Colours - Brown, Forest Green & Matt Black Custom Colours Available Upon Request.

The following note shall apply to all drawings and associated documents:
1. Copyright of this drawing and design is reserved by the Designer & European Wrought Iron Works Ltd. The drawing and all associated documents are an instrument of service by the Designer & European Wrought Iron Works Ltd. The drawing and the information contained therein may not be reproduced in whole or in part without prior written or verbal permission of the designer or European Wrought Iron Works Ltd.
2. Drawings are not to be scaled for construction. All existing site conditions and dimensions required to perform the work are to be verified and any discrepancies are to be reported to the designer & European Wrought Iron Works Ltd.
3. These drawings are not to be used for construction unless noted below as "Issued for Construction"
4. All work to be carried out in conformance with the Code and Bylaws of the authorities having jurisdiction.
5. The Designer of these plans and specifications gives no warranty or representation to any party about the constructability of the item represented by them.

CONFIDENTIAL: NOT TO BE DISCLOSED OR REPRODUCED

WITHOUT THE WRITTEN PERMISSION OF EUROPEAN WROUGHT IRON WORKS LTD.

TITLE: **Royalty Collection**
Princess with Scallop Top

TOLERANCES INCHES UNLESS OTHERWISE NOTED X.XXX" ±0.005" X.XX" ±0.05" X.X" ±0.25" FRACTIONAL ±1/16" ANGULAR ±1°	SCALE: NTS.	DATE DRAWN: June 2015	DRAWN BY: DCM
---	-------------	-----------------------	---------------

DO NOT MODIFY OR SCALE DRAWING	PROJECT TITLE:
DESIGN: P.D.	SHEET NO: 3b

DRAWING & DESIGN REMAIN THE PROPERTY OF EUROPEAN WROUGHT IRON WORKS LTD.	
FINISH: Custom	DRAWING NUMBER: RC-03e
REV 1-	A

Pineapple, Pyramid, Ball or Spear Post Cap

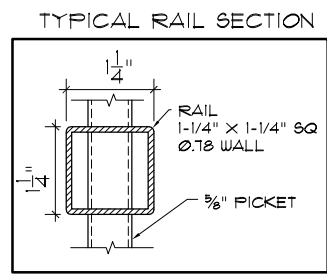
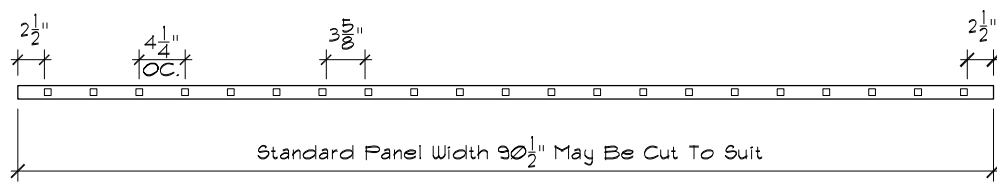
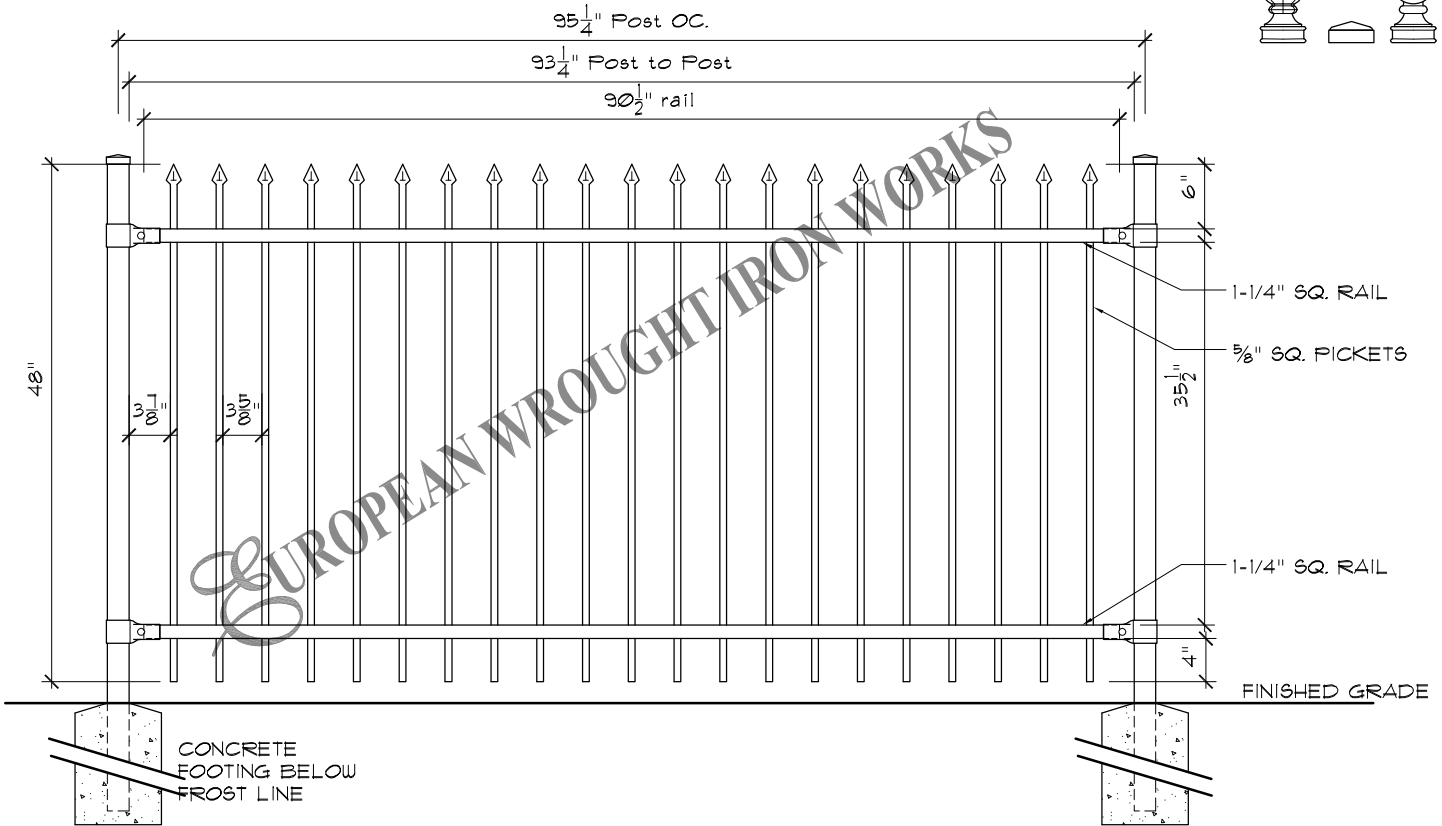
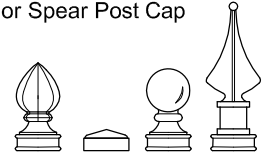

Specifications

<p>POST, RAILS & PICKETS: Cold Formed Steel Tubing Interior And Exterior Galvalume Coating Chromate Conversion Coating Electrostatically Applied Thermally Bonded Polyester Powder Coating Minimum Film Thickness 2.5 MILS</p> <p>POSTS: 2" x 2" (51mm x 51mm) 16 Gauge Standard Post Spacing 97-1/8" (2466mm) OC.</p> <p>POST CAP: Pyramid, Ball or Spear</p> <p>RAILS: 1-1/4" x 1-1/4" (32mm x 32mm) 14 Gauge</p> <p>PICKETS: 5/8" x 5/8" (15mm x 15mm) 16 Gauge</p>	<p>FITTINGS: 15 Gauge Stamp Forged Factory Finish. As Above</p> <p>WELDS: Stainless Steel</p> <p>STANDARD PANEL WIDTH: 91-1/2" (2324mm)</p> <p>AVAILABLE PANEL HEIGHTS: 48" (1219mm) (plus cap if applicable) 60" (1524mm) 72" (1828mm)</p> <p>NOTE: Tamper Proof Nut Available For Brackets</p> <p>COLOURS: Standard - High Gloss Black Optional Colours - Brown, Forest Green & Matt Black Custom Colours Available Upon Request.</p>
---	---

The following note shall apply to all drawings and associated documents:
1. Copyright of this drawing and design is reserved by the Designer & European Wrought Iron Works Ltd. The drawing and all associated documents are an instrument of service by the Designer & European Wrought Iron Works Ltd. The drawing and the information contained therein may not be reproduced in whole or in part without prior written or verbal permission of the designer or European Wrought Iron Works Ltd.
2. Drawings are not to be scaled for construction. All existing site conditions and dimensions required to perform the work are to be verified and any discrepancies are to be reported to the designer & European Wrought Iron Works Ltd.
3. These drawings are not to be used for construction unless noted below as "Issued for Construction"
4. All work to be carried out in conformance with the Code and Bylaws of the authorities having jurisdiction.
5. The Designer of these plans and specifications gives no warranty or representation to any party about the constructability of the item represented by them.

CONFIDENTIAL: NOT TO BE DISCLOSED OR REPRODUCED

EUROPEAN
WROUGHT IRON WORKS

WITHOUT THE WRITTEN PERMISSION OF EUROPEAN WROUGHT IRON WORKS LTD.

TITLE:
Royalty Collection
Princess

TOLERANCES INCHES UNLESS OTHERWISE NOTED	X.XXX" ±0.005" X.XX" ±0.05" X.X" ±0.25" FRACTIONAL ±1/16" ANGULAR ±1°
SCALE:	NTS.
DATE DRAWN:	June 2015
DRAWN BY:	DCM

DO NOT MODIFY OR SCALE DRAWING	PROJECT TITLE:
DESIGN: P.D.	FINISH: Custom
SHEET NO: 3e	DRAWING NUMBER: RC-03e

DRAWING & DESIGN REMAIN THE PROPERTY OF EUROPEAN WROUGHT IRON WORKS LTD.	
REV	A

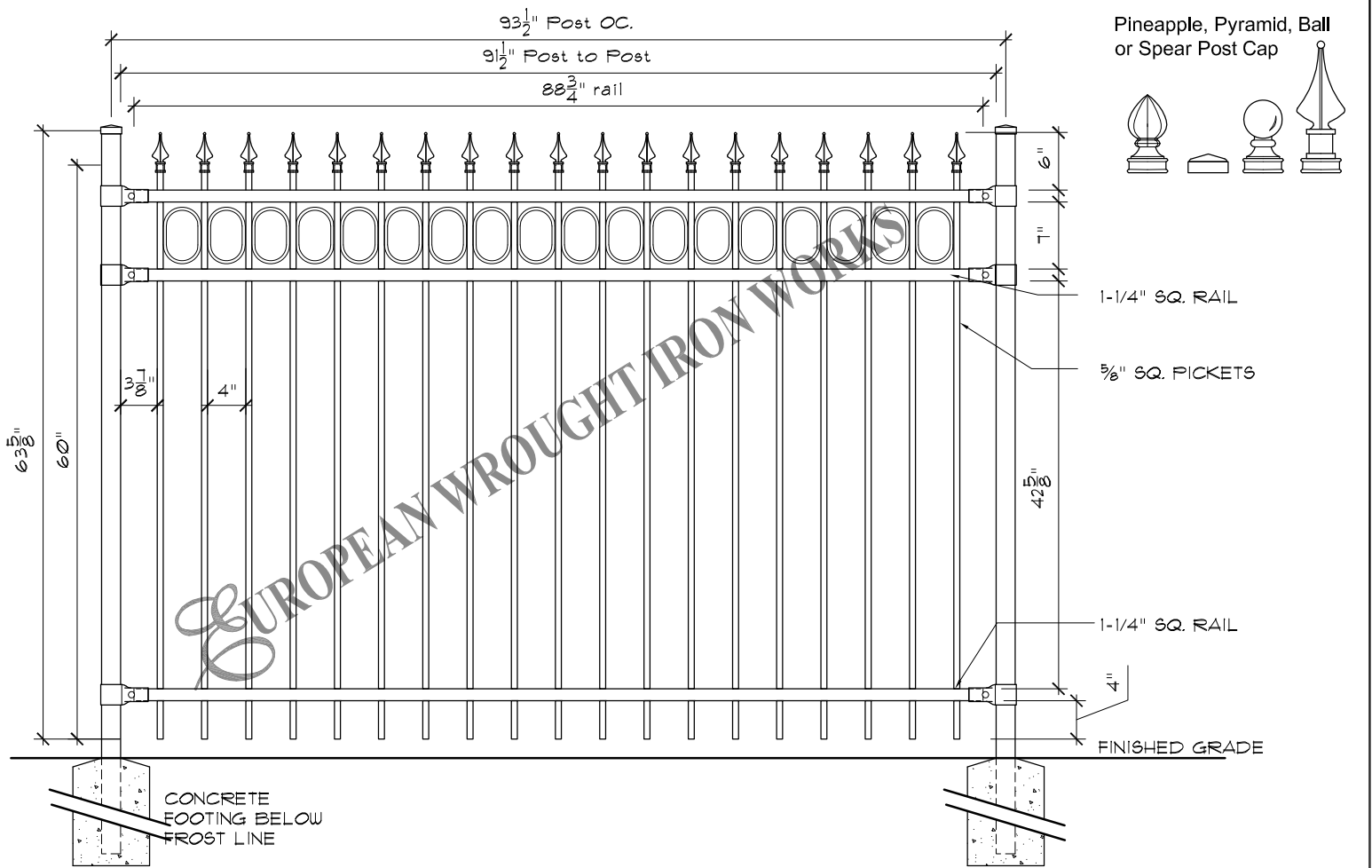

Pineapple, Pyramid, Ball or Spear Post Cap

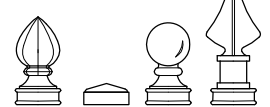

1-1/4" SQ. RAIL
5/8" SQ. PICKETS

1-1/4" SQ. RAIL
4"
FINISHED GRADE

EUROPEAN WROUGHT IRON WORKS

TYPICAL RAIL SECTION

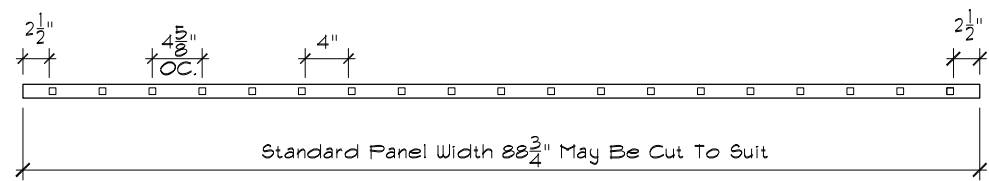
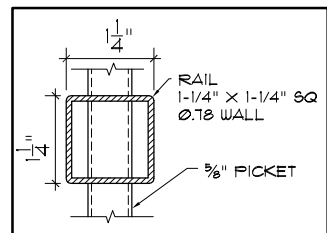

Specifications

<p>POST, RAILS & PICKETS: Cold Formed Steel Tubing Interior And Exterior Galvalume Coating Chromate Conversion Coating Electrostatically Applied Thermally Bonded Polyester Powder Coating Minimum Film Thickness 2.5 Mils</p> <p>POSTS: 2" x 2" (51mm x 51mm) 16 Gauge Standard Post Spacing 97-1/8" (2466mm) OC.</p> <p>POST CAP: Pyramid, Ball or Spear</p> <p>RAILS: 1-1/4" x 1-1/4" (32mm x 32mm) 14 Gauge</p> <p>PICKETS: 5/8" x 5/8" (15mm x 15mm) 16 Gauge</p>	<p>FITTINGS: 15 Gauge Stamp Forged Factory Finish. As Above</p> <p>WELDS: Stainless Steel</p> <p>STANDARD PANEL WIDTH: 88-3/4" (2254mm)</p> <p>AVAILABLE PANEL HEIGHTS: 48" (1219mm) (plus cap if applicable) 60" (1524mm) 72" (1828mm)</p> <p>NOTE: Tamper Proof Nut Available For Brackets</p> <p>COLOURS: Standard - High Gloss Black Optional Colours - Brown, Forest Green & Matt Black Custom Colours Available Upon Request.</p>
---	---

The following note shall apply to all drawings and associated documents:
1. Copyright of this drawing and design is reserved by the Designer & European Wrought Iron Works Ltd. The drawing and all associated documents are an instrument of service by the Designer & European Wrought Iron Works Ltd. The drawing and the information contained therein may not be reproduced in whole or in part without prior written or verbal permission of the designer or European Wrought Iron Works Ltd.
2. Drawings are not to be scaled for construction. All existing site conditions and dimensions required to perform the work are to be verified and any discrepancies are to be reported to the designer & European Wrought Iron Works Ltd.
3. These drawings are not to be used for construction unless noted below as "Issued for Construction"
4. All work to be carried out in conformance with the Code and Bylaws of the authorities having jurisdiction.
5. The Designer of these plans and specifications gives no warranty or representation to any party about the constructability of the item represented by them.

CONFIDENTIAL: NOT TO BE DISCLOSED OR REPRODUCED



ROYALTY COLLECTION
Prince

TITLE: **Royalty Collection Prince**

TOLERANCES INCHES UNLESS OTHERWISE NOTED
X.XXX" ±0.005"
X.XX" ±0.05"
X.X" ±0.25"
FRACTIONAL ±1/16"
ANGULAR ±1°

SCALE: NTS.

DATE DRAWN: June 2015

DRAWN BY: DCM

DO NOT MODIFY OR SCALE DRAWING

PROJECT TITLE:

DESIGN: P.D.

SHEET NO: 4

DRAWING & DESIGN REMAIN THE PROPERTY OF EUROPEAN WROUGHT IRON WORKS LTD.

FINISH: Custom

DRAWING NUMBER: RC-04

REV 1- A

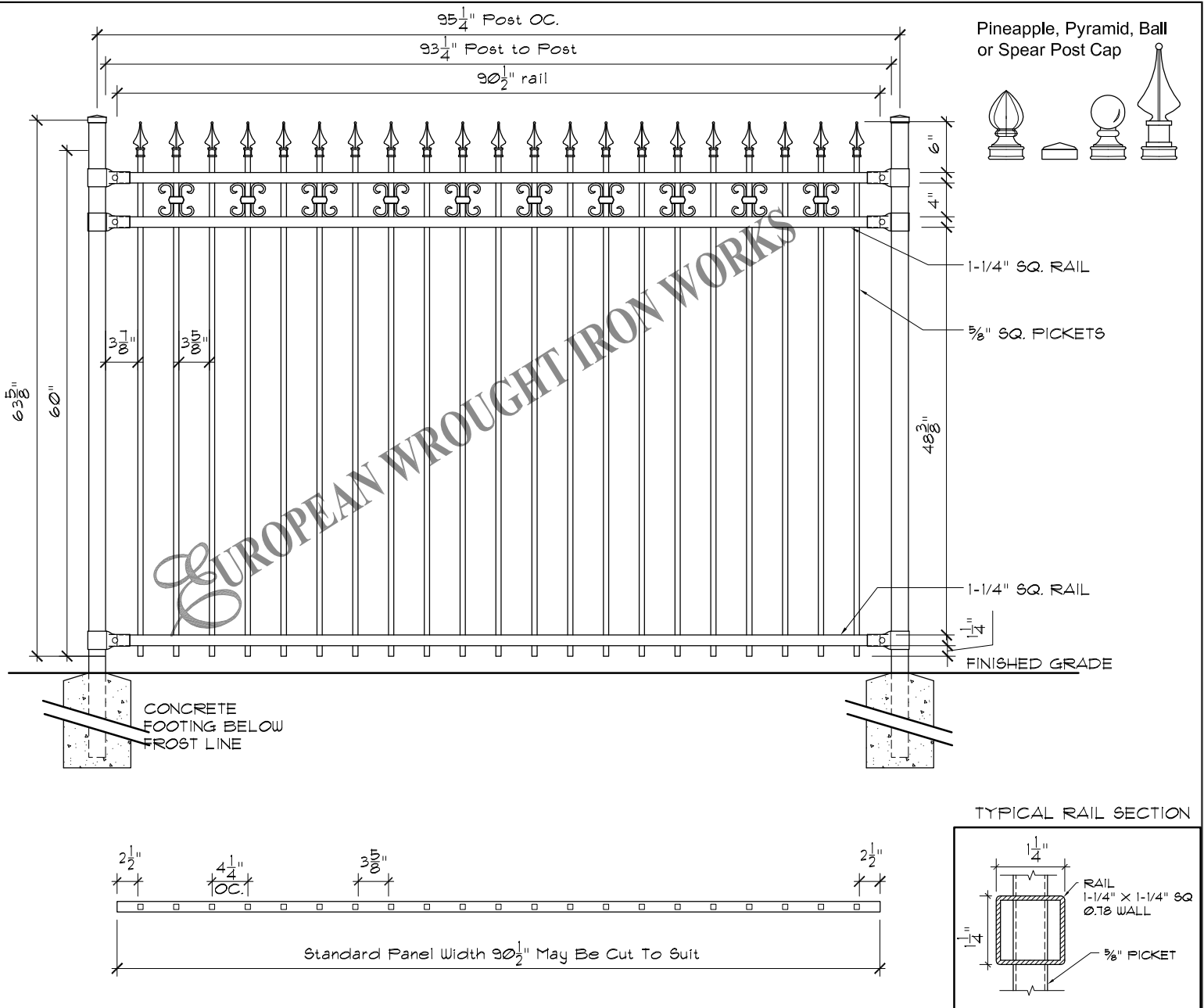

Specifications

POST, RAILS & PICKETS: Cold Formed Steel Tubing
Interior And Exterior Galvalume Coating
Chromate Conversion Coating
Electrostatically Applied
Thermally Bonded Polyester Powder Coating
Minimum Film Thickness 2.5 Mils

POSTS: 2" x 2" (51mm x 51mm) 16 Gauge
Standard Post Spacing 97-1/8" (2466mm) OC.

POST CAP: Pyramid, Ball or Spear

RAILS: 1-1/4" x 1-1/4" (32mm x 32mm) 14 Gauge

PICKETS: 5/8" x 5/8" (15mm x 15mm) 16 Gauge

FITTINGS: 15 Gauge Stamp Forged Factory Finish. As Above

WELDS: Stainless Steel

STANDARD PANEL WIDTH: 91-1/2" (2324m)

AVAILABLE PANEL HEIGHTS: 48" (1219mm)
(plus cap if applicable)
60" (1524mm)
72" (1828mm)

NOTE: Tamper Proof Nut Available For Brackets

COLOURS: Standard - High Gloss Black
Optional Colours - Brown, Forest Green & Matt Black
Custom Colours Available Upon Request.

The following note shall apply to all drawings and associated documents:

- Copyright of this drawing and design is reserved by the Designer & European Wrought Iron Works Ltd. The drawing and all associated documents are an instrument of service by the Designer & European Wrought Iron Works Ltd. The drawing and the information contained therein may not be reproduced in whole or in part without prior written or verbal permission of the designer or European Wrought Iron Works Ltd.
- Drawings are not to be scaled for construction. All existing site conditions and dimensions required to perform the work are to be verified and any discrepancies are to be reported to the designer & European Wrought Iron Works Ltd.
- These drawings are not to be used for construction unless noted below as "Issued for Construction"
- All work to be carried out in conformance with the Code and Bylaws of the authorities having jurisdiction.
- The Designer of these plans and specifications gives no warranty or representation to any party about the constructability of the item represented by them.

CONFIDENTIAL: NOT TO BE DISCLOSED OR REPRODUCED

EUROPEAN
WROUGHT IRON WORKS
WITHOUT THE WRITTEN PERMISSION OF EUROPEAN WROUGHT IRON WORKS LTD.

TITLE:

Royalty Collection
Prince Custom PS.

TOLERANCES
INCHES
UNLESS OTHERWISE NOTED
X.XXX" ±0.005"
X.XX" ±0.05"
X.X" ±0.25"
FRACTIONAL ±1/16"
ANGULAR ±1°

SCALE: NTS.
DATE DRAWN: June 2015
DRAWN BY: DCM

DO NOT
MODIFY OR
SCALE DRAWING

PROJECT TITLE:

DESIGN: P.D.
SHEET NO: 4i

DRAWING & DESIGN REMAIN THE PROPERTY OF EUROPEAN WROUGHT IRON WORKS LTD.

FINISH: Custom
DRAWING NUMBER: RC-04i

REV 1- A

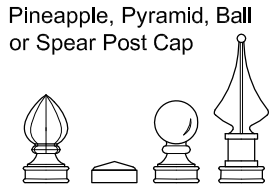
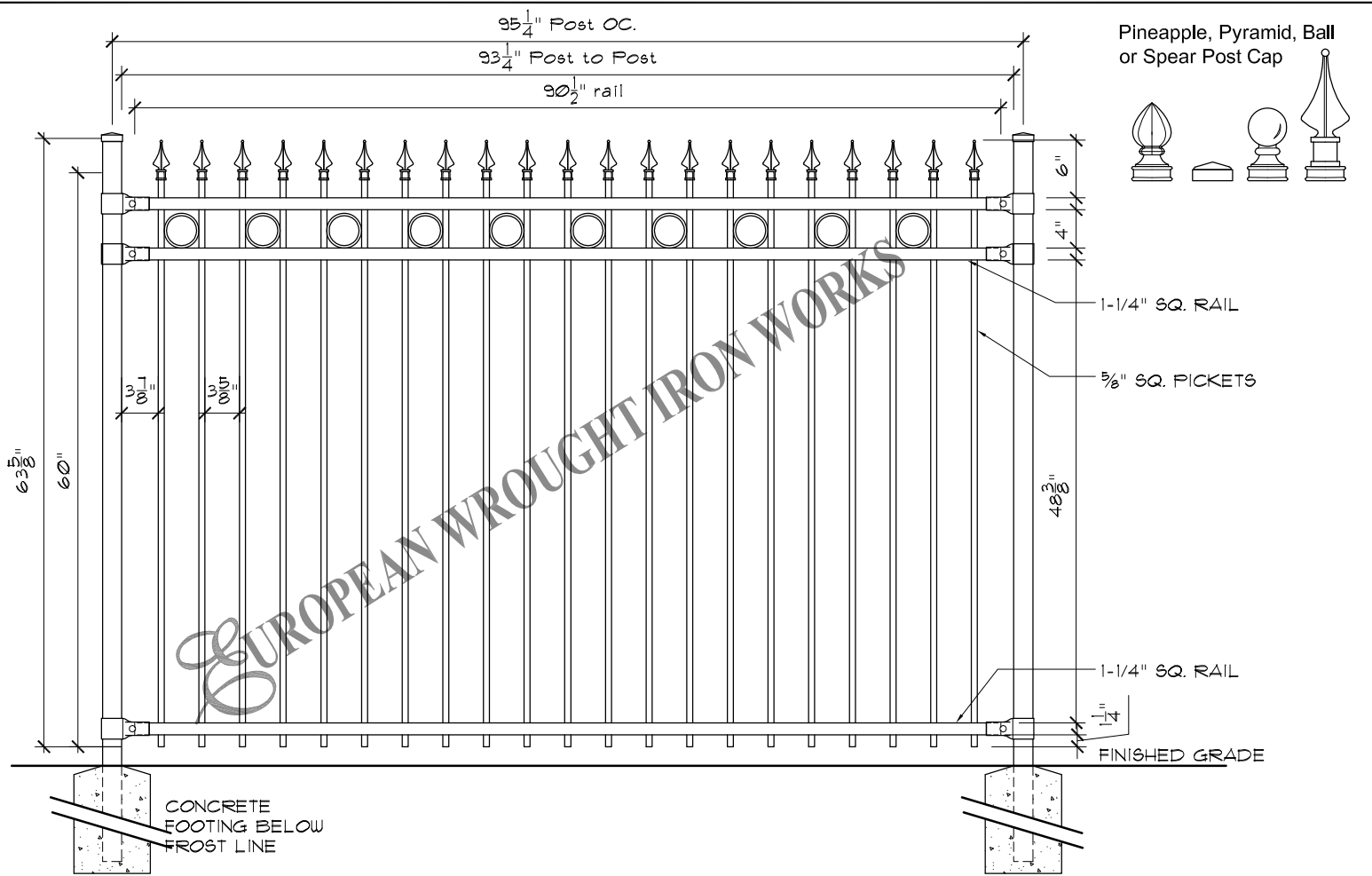

EUROPEAN WROUGHT IRON WORKS

TYPICAL RAIL SECTION

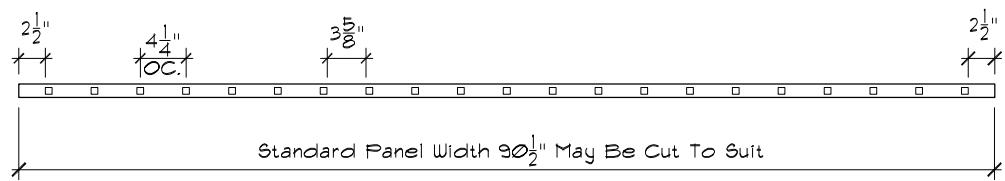
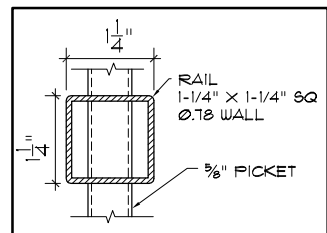

Specifications

<p>POST, RAILS & PICKETS: Cold Formed Steel Tubing Interior And Exterior Galvalume Coating Chromate Conversion Coating Electrostatically Applied Thermally Bonded Polyester Powder Coating Minimum Film Thickness 2.5 Mils</p> <p>POSTS: 2" x 2" (51mm x 51mm) 16 Gauge Standard Post Spacing 97-1/8" (2466mm) OC.</p> <p>POST CAP: Pyramid, Ball or Spear</p> <p>RAILS: 1-1/4" x 1-1/4" (32mm x 32mm) 14 Gauge</p> <p>PICKETS: 5/8" x 5/8" (15mm x 15mm) 16 Gauge</p>	<p>FITTINGS: 15 Gauge Stamp Forged Factory Finish. As Above</p> <p>WELDS: Stainless Steel</p> <p>STANDARD PANEL WIDTH: 91-1/2" (2324mm)</p> <p>AVAILABLE PANEL HEIGHTS: 48" (1219mm) (plus cap if applicable) 60" (1524mm) 72" (1828mm)</p> <p>NOTE: Tamper Proof Nut Available For Brackets</p> <p>COLOURS: Standard - High Gloss Black Optional Colours - Brown, Forest Green & Matt Black Custom Colours Available Upon Request.</p>
---	---

<p>The following note shall apply to all drawings and associated documents:</p> <p>1. Copyright of this drawing and design is reserved by the Designer & European Wrought Iron Works Ltd. The drawing and all associated documents are an instrument of service by the Designer & European Wrought Iron Works Ltd. The drawing and the information contained therein may not be reproduced in whole or in part without prior written or verbal permission of the designer or European Wrought Iron Works Ltd.</p> <p>2. Drawings are not to be scaled for construction. All existing site conditions and dimensions required to perform the work are to be verified and any discrepancies are to be reported to the designer & European Wrought Iron Works Ltd.</p> <p>3. These drawings are not to be used for construction unless noted below as "Issued for Construction"</p> <p>4. All work to be carried out in conformance with the Code and Bylaws of the authorities having jurisdiction.</p> <p>5. The Designer of these plans and specifications gives no warranty or representation to any party about the constructability of the item represented by them.</p>	<p style="font-size: 8px;">CONFIDENTIAL: NOT TO BE DISCLOSED OR REPRODUCED</p> <p style="font-size: 8px;">WITHOUT THE WRITTEN PERMISSION OF EUROPEAN WROUGHT IRON WORKS LTD.</p>	<p>TOLERANCES INCHES UNLESS OTHERWISE NOTED X.XXX" ±0.005" X.XX" ±0.05" X.X" ±0.25" FRACTIONAL ±1/16" ANGULAR ±1°</p>	<p>DO NOT MODIFY OR SCALE DRAWING</p>	<p>DRAWING & DESIGN REMAIN THE PROPERTY OF EUROPEAN WROUGHT IRON WORKS LTD.</p> <p>PROJECT TITLE:</p>
<p>TITLE: Royalty Collection <i>Prince Custom with Alt. Circle</i></p>	<p>SCALE: NTS.</p> <p>DATE DRAWN: June 2020</p> <p>DRAWN BY: DCM</p>	<p>DESIGN: P.D.</p> <p>SHEET NO: 4k(i)</p>	<p>FINISH: Custom</p> <p>DRAWING NUMBER: RC-04k(i)</p>	<p>REV: 1- A</p>

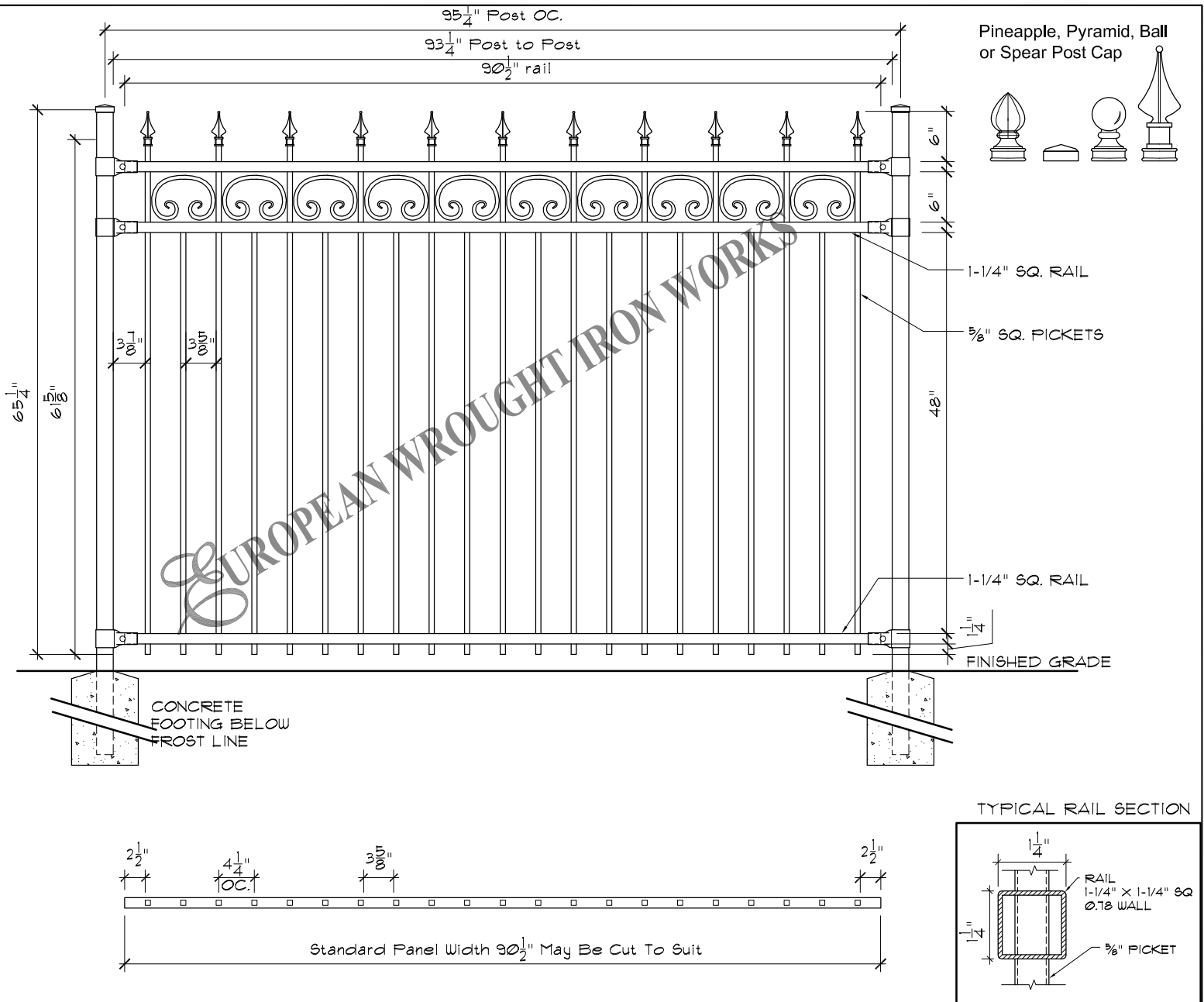

Specifications

POST, RAILS & PICKETS: Cold Formed Steel Tubing
Interior And Exterior Galvalume Coating
Chromate Conversion Coating
Electrostatically Applied
Thermally Bonded Polyester Powder Coating
Minimum Film Thickness 2.5 Mils

POSTS: 2" x 2" (51mm x 51mm) 16 Gauge
Standard Post Spacing 97-1/8" (2466mm) OC.

POST CAP: Pyramid, Ball or Spear

RAILS: 1-1/4" x 1-1/4" (32mm x 32mm) 14 Gauge

PICKETS: 5/8" x 5/8" (15mm x 15mm) 16 Gauge

FITTINGS: 15 Gauge Stamp Forged Factory Finish. As Above

WELDS: Stainless Steel

STANDARD PANEL WIDTH: 91-1/2" (2324mm)

AVAILABLE PANEL HEIGHTS: 48" (1219mm)
(plus cap if applicable)
60" (1524mm)
72" (1828mm)

NOTE: Tamper Proof Nut Available For Brackets

COLOURS: Standard - High Gloss Black
Optional Colours - Brown, Forest Green & Matt Black
Custom Colours Available Upon Request.

The following note shall apply to all drawings and associated documents:

- Copyright of this drawing and design is reserved by the Designer & European Wrought Iron Works Ltd. The drawing and all associated documents are an instrument of service by the Designer & European Wrought Iron Works Ltd. The drawing and the information contained therein may not be reproduced in whole or in part without prior written or verbal permission of the designer or European Wrought Iron Works Ltd.
- Drawings are not to be scaled for construction. All existing site conditions and dimensions required to perform the work are to be verified and any discrepancies are to be reported to the designer & European Wrought Iron Works Ltd.
- These drawings are not to be used for construction unless noted below as "Issued for Construction"
- All work to be carried out in conformance with the Code and Bylaws of the authorities having jurisdiction.
- The Designer of these plans and specifications gives no warranty or representation to any party about the constructability of the item represented by them.

CONFIDENTIAL: NOT TO BE DISCLOSED OR REPRODUCED

EUROPEAN
WROUGHT IRON WORKS
WITHOUT THE WRITTEN PERMISSION OF EUROPEAN WROUGHT IRON WORKS LTD.

TITLE: **Royalty Collection**
Prince Custom with Scroll (Q)

TOLERANCES
INCHES
UNLESS OTHERWISE NOTED
X.XXX" ±0.005"
X.XX" ±0.05"
X.X" ±0.25"
FRACTIONAL ±1/16"
ANGULAR ±1°

SCALE: NTS.
DATE DRAWN: Sep 2017
DRAWN BY: DCM

DO NOT
MODIFY OR
SCALE DRAWING

PROJECT TITLE:

DRAWING & DESIGN REMAIN THE PROPERTY OF EUROPEAN WROUGHT IRON WORKS LTD.

DESIGN: P.D.
SHEET NO: 4q

FINISH: Custom
DRAWING NUMBER: RC-04q

REV 1- A

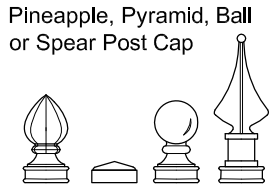
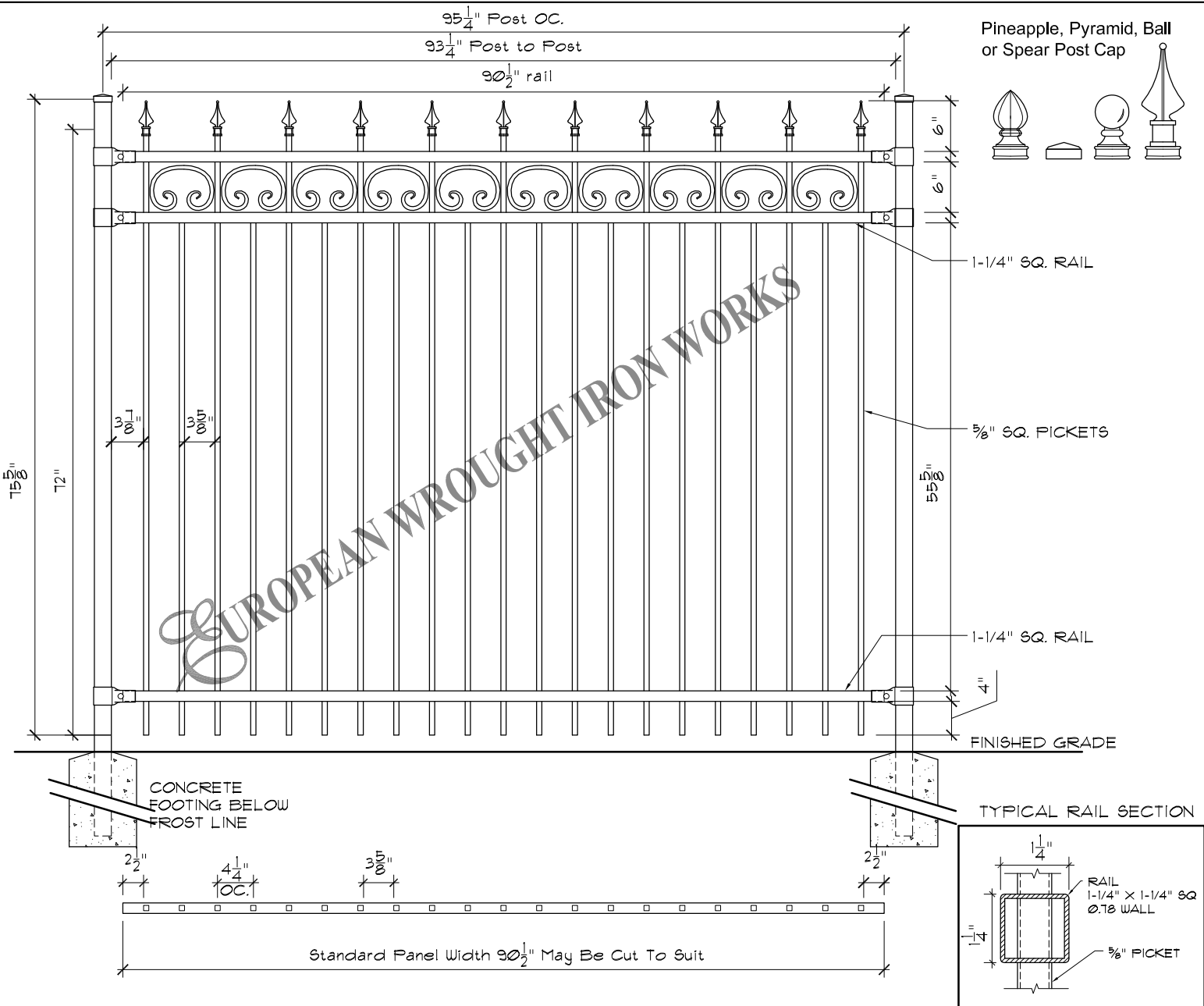

Specifications

<p>POST, RAILS & PICKETS: Cold Formed Steel Tubing Interior And Exterior Galvalume Coating Chromate Conversion Coating Electrostatically Applied Thermally Bonded Polyester Powder Coating Minimum Film Thickness 2.5 Mills</p> <p>POSTS: 2" x 2" (51mm x 51mm) 16 Gauge Standard Post Spacing 97-1/8" (2466mm) OC.</p> <p>POST CAP: Pyramid, Ball or Spear</p> <p>RAILS: 1-1/4" x 1-1/4" (32mm x 32mm) 14 Gauge</p> <p>PICKETS: 5/8" x 5/8" (15mm x 15mm) 16 Gauge</p>	<p>FITTINGS: 15 Gauge Stamp Forged Factory Finish. As Above</p> <p>WELDS: Stainless Steel</p> <p>STANDARD PANEL WIDTH: 91-1/2" (2324mm)</p> <p>AVAILABLE PANEL HEIGHTS: 48" (1219mm) (plus cap if applicable) 60" (1524mm) 72" (1828mm)</p> <p>NOTE: Tamper Proof Nut Available For Brackets</p> <p>COLOURS: Standard - High Gloss Black Optional Colours - Brown, Forest Green & Matt Black Custom Colours Available Upon Request.</p>
--	---

<p>The following note shall apply to all drawings and associated documents:</p> <p>1. Copyright of this drawing and design is reserved by the Designer & European Wrought Iron Works Ltd. The drawing and all associated documents are an instrument of service by the Designer & European Wrought Iron Works Ltd. The drawing and the information contained therein may not be reproduced in whole or in part without prior written or verbal permission of the designer or European Wrought Iron Works Ltd.</p> <p>2. Drawings are not to be scaled for construction. All existing site conditions and dimensions required to perform the work are to be verified and any discrepancies are to be reported to the designer & European Wrought Iron Works Ltd.</p> <p>3. These drawings are not to be used for construction unless noted below as "Issued for Construction"</p> <p>4. All work to be carried out in conformance with the Code and Bylaws of the authorities having jurisdiction.</p> <p>5. The Designer of these plans and specifications gives no warranty or representation to any party about the constructability of the item represented by them.</p>	<p style="font-size: 8px;">CONFIDENTIAL: NOT TO BE DISCLOSED OR REPRODUCED</p> <p style="font-size: 8px;">WITHOUT THE WRITTEN PERMISSION OF EUROPEAN WROUGHT IRON WORKS LTD.</p>	<p>TOLERANCES INCHES UNLESS OTHERWISE NOTED X.XXX" ±0.005" X.XX" ±0.05" X.X" ±0.25" FRACTIONAL ±1/16" ANGULAR ±1°</p>	<p>DO NOT MODIFY OR SCALE DRAWING</p> <p>PROJECT TITLE:</p>	<p>DRAWING & DESIGN REMAIN THE PROPERTY OF EUROPEAN WROUGHT IRON WORKS LTD.</p>
<p>TITLE: Royalty Collection <i>Prince Custom with Scroll (R)</i></p>	<p>SCALE: NTS.</p> <p>DATE DRAWN: Sep 2017</p> <p>DRAWN BY: DCM</p>	<p>DESIGN: P.D.</p> <p>SHEET NO: 4r</p>	<p>FINISH: Custom</p> <p>DRAWING NUMBER: RC-04r</p>	<p>REV 1- A</p>

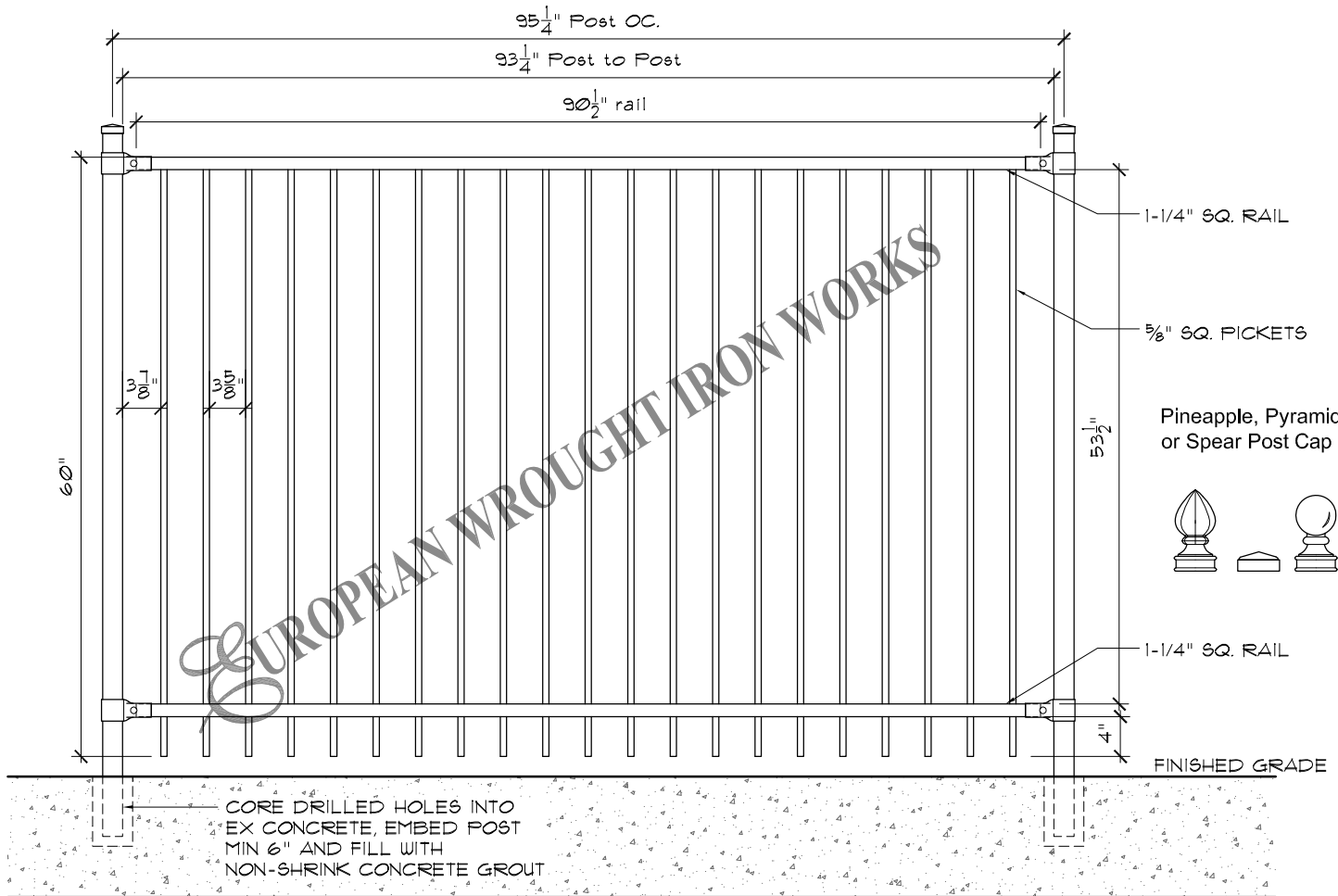

TYPICAL RAIL SECTION

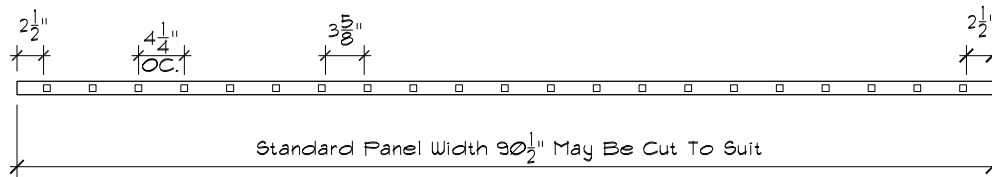
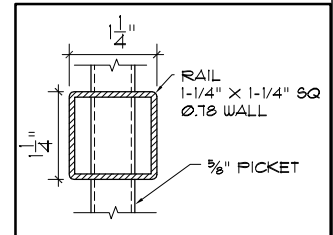

Specifications

<p>POST, RAILS & PICKETS: Cold Formed Steel Tubing Interior And Exterior Galvalume Coating Chromate Conversion Coating Electrostatically Applied Thermally Bonded Polyester Powder Coating Minimum Film Thickness 2.5 Mils</p> <p>POSTS: 2" x 2" (51mm x 51mm) 16 Gauge Standard Post Spacing 97-1/8" (2466mm) OC.</p> <p>POST CAP: Pyramid, Ball or Spear</p> <p>RAILS: 1-1/4" x 1-1/4" (32mm x 32mm) 14 Gauge</p> <p>PICKETS: 5/8" x 5/8" (15mm x 15mm) 16 Gauge</p>	<p>FITTINGS: 15 Gauge Stamp Forged Factory Finish. As Above</p> <p>WELDS: Stainless Steel</p> <p>STANDARD PANEL WIDTH: 91-1/2" (2324mm)</p> <p>AVAILABLE PANEL HEIGHTS: 48" (1219mm) (plus cap if applicable) 60" (1524mm) 72" (1828mm)</p> <p>NOTE: Tamper Proof Nut Available For Brackets</p> <p>COLOURS: Standard - High Gloss Black Optional Colours - Brown, Forest Green & Matt Black Custom Colours Available Upon Request.</p>
---	---

The following note shall apply to all drawings and associated documents:
 1. Copyright of this drawing and design is reserved by the Designer & European Wrought Iron Works Ltd. The drawing and all associated documents are an instrument of service by the Designer & European Wrought Iron Works Ltd. The drawing and the information contained therein may not be reproduced in whole or in part without prior written or verbal permission of the designer or European Wrought Iron Works Ltd.
 2. Drawings are not to be scaled for construction. All existing site conditions and dimensions required to perform the work are to be verified and any discrepancies are to be reported to the designer & European Wrought Iron Works Ltd.
 3. These drawings are not to be used for construction unless noted below as "Issued for Construction"
 4. All work to be carried out in conformance with the Code and Bylaws of the authorities having jurisdiction.
 5. The Designer of these plans and specifications gives no warranty or representation to any party about the constructability of the item represented by them.

CONFIDENTIAL: NOT TO BE DISCLOSED OR REPRODUCED

EUROPEAN
WROUGHT IRON WORKS
WITHOUT THE WRITTEN PERMISSION OF EUROPEAN WROUGHT IRON WORKS LTD.

TITLE:
Royalty Collection
Lord Custom with Dbl. Top Rail

TOLERANCES
INCHES
UNLESS OTHERWISE NOTED
X.XXX" ±0.005"
X.XX" ±0.05"
X.X" ±0.25"
FRACTIONAL ±1/16"
ANGULAR ±1°

SCALE: NTS.

DATE DRAWN: July 2021

DRAWN BY: DCM

DO NOT MODIFY OR SCALE DRAWING

PROJECT TITLE:

DESIGN: P.D.

SHEET NO: 5r

DRAWING & DESIGN REMAIN THE PROPERTY OF EUROPEAN WROUGHT IRON WORKS LTD.

FINISH: Custom

DRAWING NUMBER: RC-05s

REV
1- A

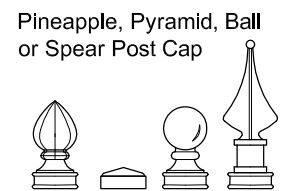
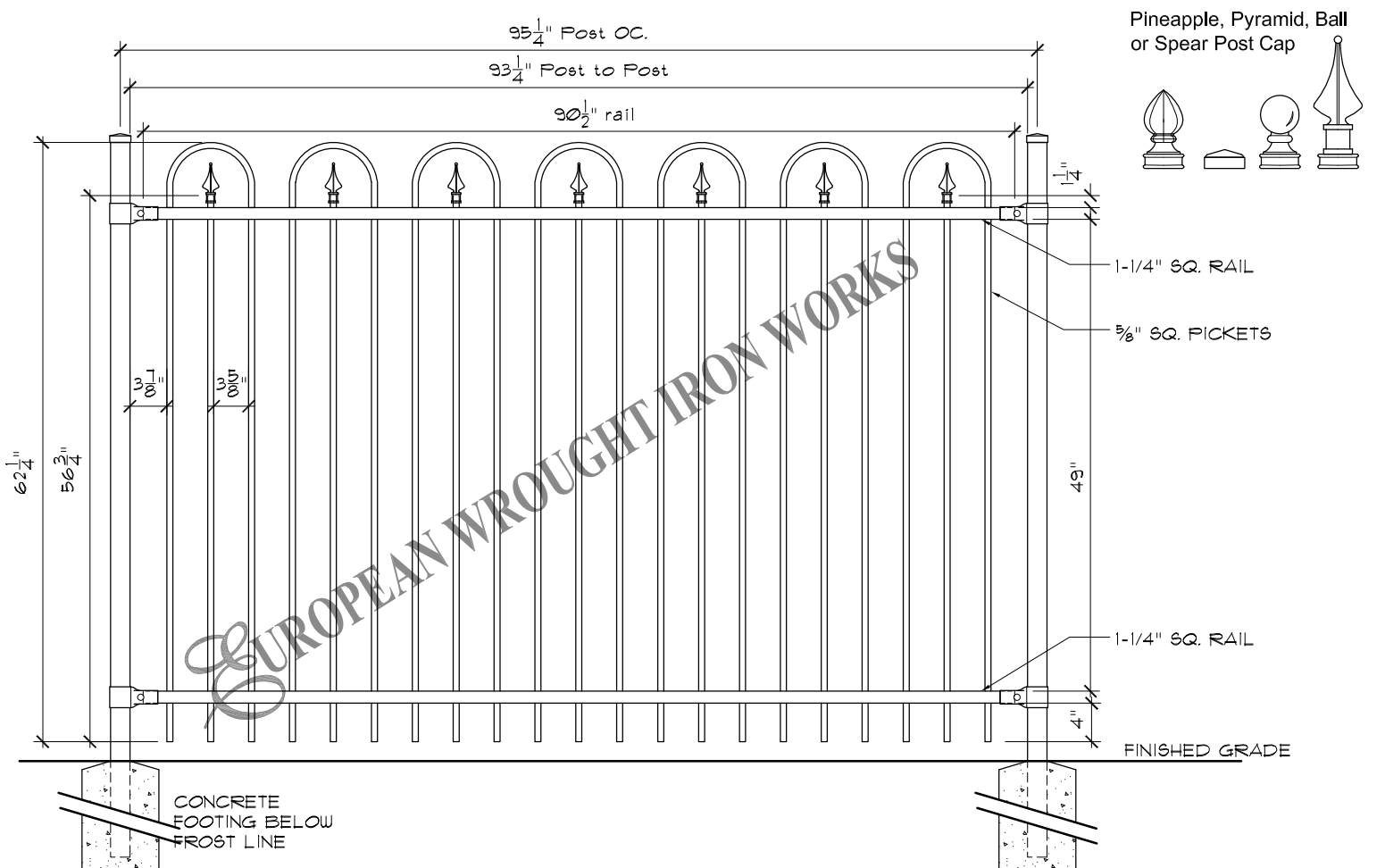

1-1/4" SQ. RAIL
5/8" SQ. PICKETS

1-1/4" SQ. RAIL
FINISHED GRADE

CONCRETE FOOTING BELOW FROST LINE

TYPICAL RAIL SECTION

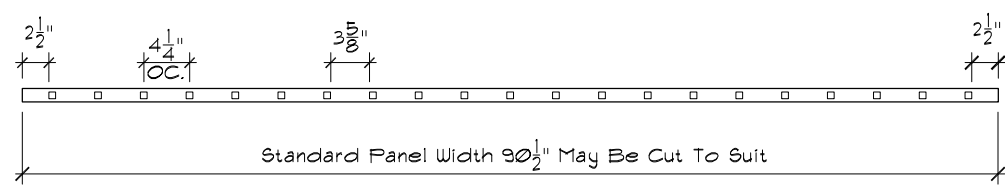
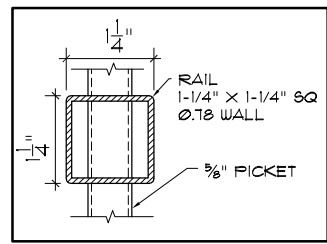

Specifications

<p>POST, RAILS & PICKETS: Cold Formed Steel Tubing Interior And Exterior Galvalume Coating Chromate Conversion Coating Electrostatically Applied Thermally Bonded Polyester Powder Coating Minimum Film Thickness 2.5 Mils</p> <p>POSTS: 2" x 2" (51mm x 51mm) 16 Gauge Standard Post Spacing 97-1/8" (2466mm) OC.</p> <p>POST CAP: Pyramid, Ball or Spear</p> <p>RAILS: 1-1/4" x 1-1/4" (32mm x 32mm) 14 Gauge</p> <p>PICKETS: 5/8" x 5/8" (15mm x 15mm) 16 Gauge</p>	<p>FITTINGS: 15 Gauge Stamp Forged Factory Finish. As Above</p> <p>WELDS: Stainless Steel</p> <p>STANDARD PANEL WIDTH: 91-1/2" (2324mm)</p> <p>AVAILABLE PANEL HEIGHTS: 48" (1219mm) (plus cap if applicable) 60" (1524mm) 72" (1828mm)</p> <p>NOTE: Tamper Proof Nut Available For Brackets</p> <p>COLOURS: Standard - High Gloss Black Optional Colours - Brown, Forest Green & Matt Black Custom Colours Available Upon Request.</p>
---	---

The following note shall apply to all drawings and associated documents:
1. Copyright of this drawing and design is reserved by the Designer & European Wrought Iron Works Ltd. The drawing and all associated documents are an instrument of service by the Designer & European Wrought Iron Works Ltd. The drawing and the information contained therein may not be reproduced in whole or in part without prior written or verbal permission of the designer or European Wrought Iron Works Ltd.
2. Drawings are not to be scaled for construction. All existing site conditions and dimensions required to perform the work are to be verified and any discrepancies are to be reported to the designer & European Wrought Iron Works Ltd.
3. These drawings are not to be used for construction unless noted below as "Issued for Construction"
4. All work to be carried out in conformance with the Code and Bylaws of the authorities having jurisdiction.
5. The Designer of these plans and specifications gives no warranty or representation to any party about the constructability of the item represented by them.

CONFIDENTIAL: NOT TO BE DISCLOSED OR REPRODUCED



WITHOUT THE WRITTEN PERMISSION OF EUROPEAN WROUGHT IRON WORKS LTD.

TITLE:
Royalty Collection
Conqueror

TOLERANCES INCHES UNLESS OTHERWISE NOTED	
X.XXX" ±0.005"	
X.XX" ±0.05"	
X.X" ±0.25"	
FRACTIONAL ±1/16"	
ANGULAR ±1°	
SCALE:	NTS.
DATE DRAWN:	June 2015
DRAWN BY:	DCM

DO NOT MODIFY OR SCALE DRAWING	DRAWING & DESIGN REMAIN THE PROPERTY OF EUROPEAN WROUGHT IRON WORKS LTD.		
PROJECT TITLE:			
DESIGN:	P.D.	FINISH:	Custom
SHEET NO:	6	DRAWING NUMBER:	RC-06
		REV	1- A

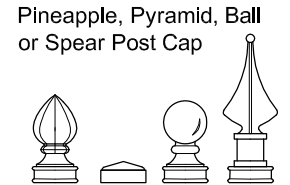
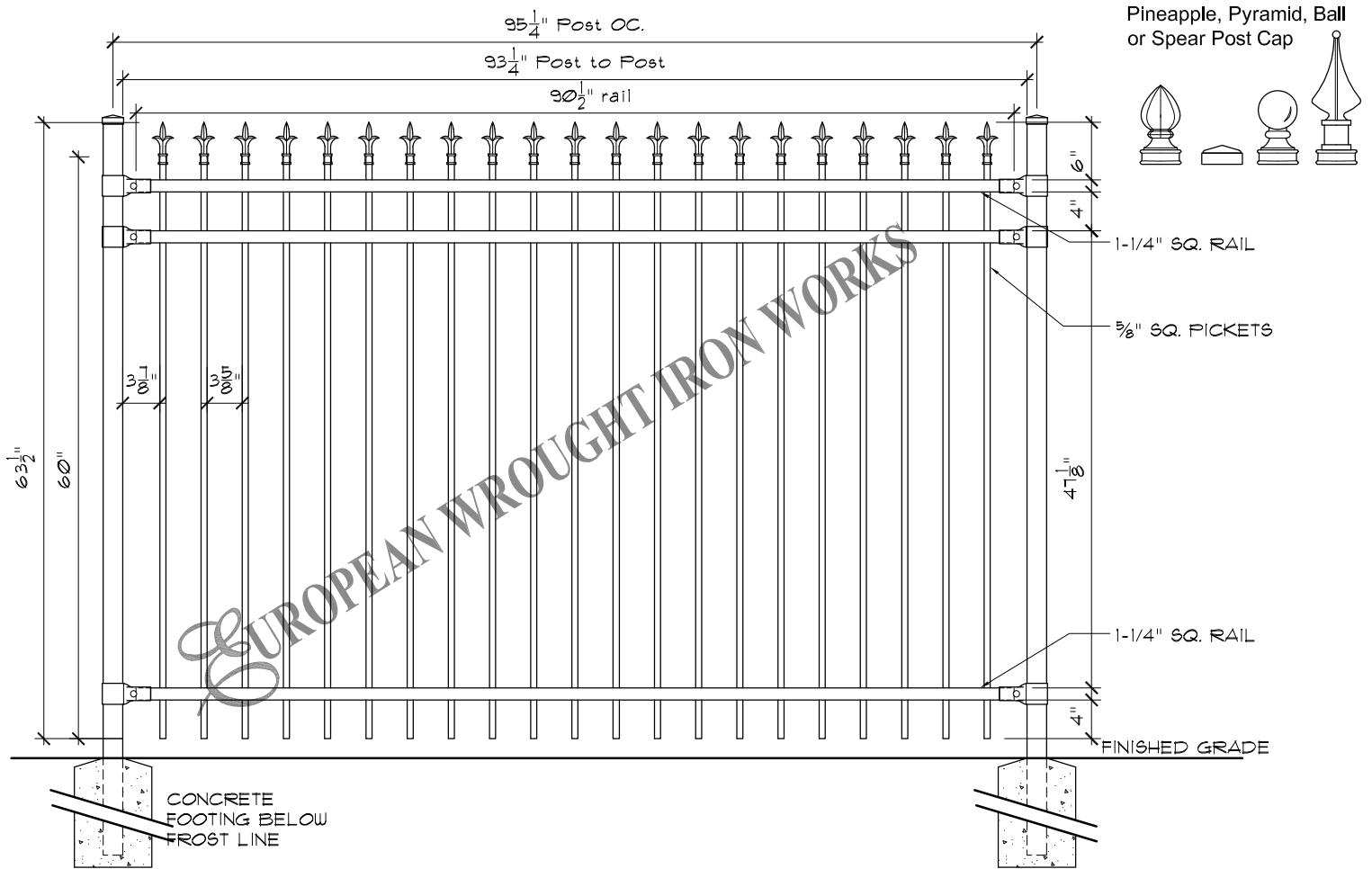

EUROPEAN WROUGHT IRON WORKS

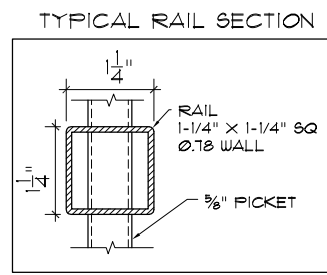
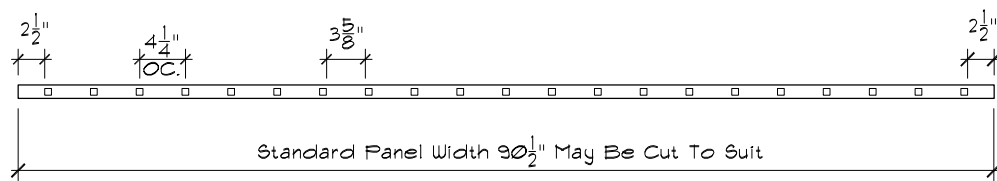

Specifications

POST, RAILS & PICKETS: Cold Formed Steel Tubing
Interior And Exterior Galvalume Coating
Chromate Conversion Coating
Electrostatically Applied
Thermally Bonded Polyester Powder Coating
Minimum Film Thickness 2.5 Mils

POSTS: 2" x 2" (51mm x 51mm) 16 Gauge
Standard Post Spacing 97-1/8" (2466mm) OC.

POST CAP: Pyramid, Ball or Spear

RAILS: 1-1/4" x 1-1/4" (32mm x 32mm) 14 Gauge

PICKETS: 5/8" x 5/8" (15mm x 15mm) 16 Gauge

FITTINGS: 15 Gauge Stamp Forged Factory Finish. As Above

WELDS: Stainless Steel

STANDARD PANEL WIDTH: 91-1/2" (2324mm)

AVAILABLE PANEL HEIGHTS: 48" (1219mm)
(plus cap if applicable) 60" (1524mm)
72" (1828mm)

NOTE: Tamper Proof Nut Available For Brackets

COLOURS: Standard - High Gloss Black
Optional Colours - Brown, Forest Green & Matt Black
Custom Colours Available Upon Request.

Information subject to change without notice

The following note shall apply to all drawings and associated documents:
1. Copyright of this drawing and design is reserved by the Designer & European Wrought Iron Works Ltd. The drawing and all associated documents are an instrument of service by the Designer & European Wrought Iron Works Ltd. The drawing and the information contained therein may not be reproduced in whole or in part without prior written or verbal permission of the designer or European Wrought Iron Works Ltd.
2. Drawings are not to be scaled for construction. All existing site conditions and dimensions required to perform the work are to be verified and any discrepancies are to be reported to the designer & European Wrought Iron Works Ltd.
3. These drawings are not to be used for construction unless noted below as "Issued for Construction"
4. All work to be carried out in conformance with the Code and Bylaws of the authorities having jurisdiction.
5. The Designer of these plans and specifications gives no warranty or representation to any party about the constructability of the item represented by them.

CONFIDENTIAL: NOT TO BE DISCLOSED OR REPRODUCED

EUROPEAN
WROUGHT IRON WORKS
WITHOUT THE WRITTEN PERMISSION OF EUROPEAN WROUGHT IRON WORKS LTD.

TITLE:
Royalty Collection
Emperor with Dbl. Top Rail

TOLERANCES
INCHES
UNLESS OTHERWISE NOTED
X.XXX" ±0.005"
X.XX" ±0.05"
X.X" ±0.25"
FRACTIONAL ±1/16"
ANGULAR ±1°

SCALE: NTS.

DATE DRAWN: June 2015

DRAWN BY: DCM

DO NOT MODIFY OR SCALE DRAWING

PROJECT TITLE:

DESIGN: P.D.

SHEET NO: 8a

DRAWING & DESIGN REMAIN THE PROPERTY OF EUROPEAN WROUGHT IRON WORKS LTD.

FINISH: Custom

DRAWING NUMBER: RC-08a

REV
1- A

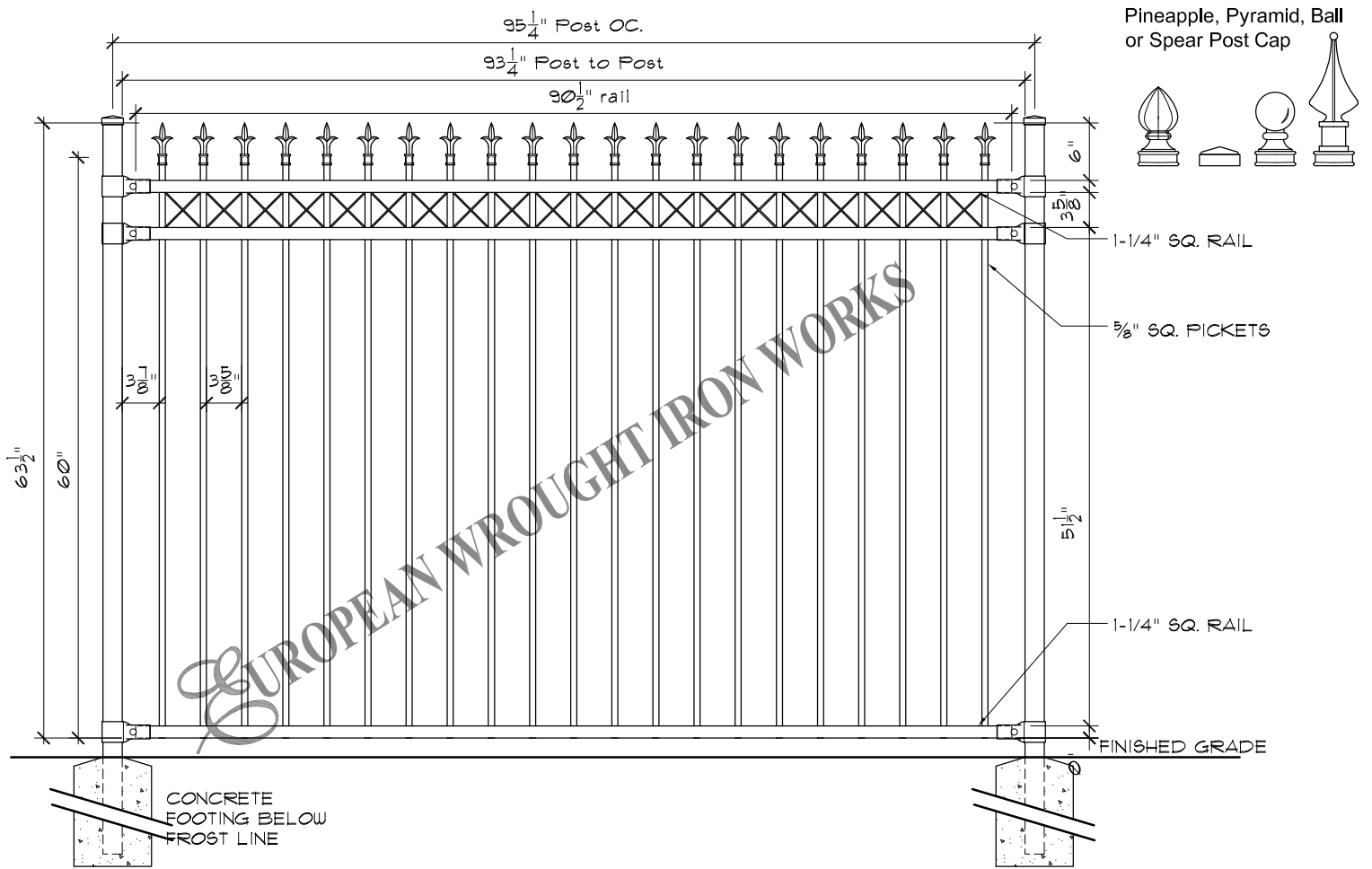

Pineapple, Pyramid, Ball or Spear Post Cap

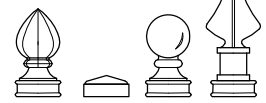

1-1/4" SQ. RAIL

5/8" SQ. PICKETS

1-1/4" SQ. RAIL

FINISHED GRADE

CONCRETE FOOTING BELOW FROST LINE

TYPICAL RAIL SECTION

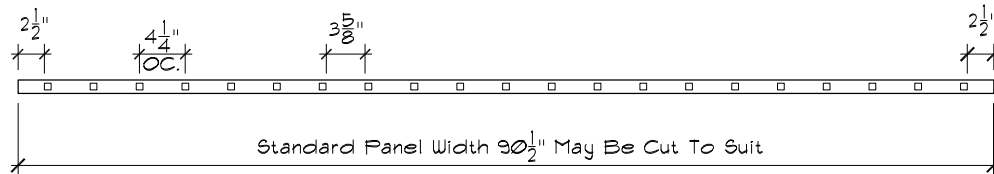
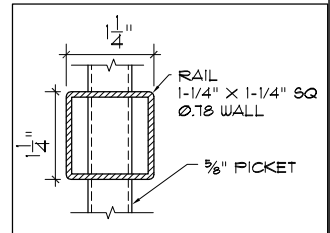

Specifications

<p>POST, RAILS & PICKETS: Cold Formed Steel Tubing Interior And Exterior Galvalume Coating Chromate Conversion Coating Electrostatically Applied Thermally Bonded Polyester Powder Coating Minimum Film Thickness 2.5 Mils</p> <p>POSTS: 2" x 2" (51mm x 51mm) 16 Gauge Standard Post Spacing 97-1/8" (2466mm) OC.</p> <p>POST CAP: Pyramid, Ball or Spear</p> <p>RAILS: 1-1/4" x 1-1/4" (32mm x 32mm) 14 Gauge</p> <p>PICKETS: 5/8" x 5/8" (15mm x 15mm) 16 Gauge</p>	<p>FITTINGS: 15 Gauge Stamp Forged Factory Finish. As Above</p> <p>WELDS: Stainless Steel</p> <p>STANDARD PANEL WIDTH: 91-1/2" (2324m)</p> <p>AVAILABLE PANEL HEIGHTS: 48" (1219mm) (plus cap if applicable) 60" (1524mm) 72" (1828mm)</p> <p>NOTE: Tamper Proof Nut Available For Brackets</p> <p>COLOURS: Standard - High Gloss Black Optional Colours - Brown, Forest Green & Matt Black Custom Colours Available Upon Request.</p>
---	--

Information subject to change without notice

The following note shall apply to all drawings and associated documents:
1. Copyright of this drawing and design is reserved by the Designer & European Wrought Iron Works Ltd. The drawing and all associated documents are an instrument of service by the Designer & European Wrought Iron Works Ltd. The drawing and the information contained therein may not be reproduced in whole or in part without prior written or verbal permission of the designer or European Wrought Iron Works Ltd.
2. Drawings are not to be scaled for construction. All existing site conditions and dimensions required to perform the work are to be verified and any discrepancies are to be reported to the designer & European Wrought Iron Works Ltd.
3. These drawings are not to be used for construction unless noted below as "Issued for Construction"
4. All work to be carried out in conformance with the Code and Bylaws of the authorities having jurisdiction.
5. The Designer of these plans and specifications gives no warranty or representation to any party about the constructability of the item represented by them.

CONFIDENTIAL: NOT TO BE DISCLOSED OR REPRODUCED

ROYALTY COLLECTION
Emperor Custom with Cross

TITLE: **Royalty Collection**
Emperor Custom with Cross

TOLERANCES INCHES UNLESS OTHERWISE NOTED
X.XXX" ±0.005"
X.XX" ±0.05"
X.X" ±0.25"
FRACTIONAL ±1/16"
ANGULAR ±1°

SCALE: NTS.

DATE DRAWN: June 2015

DRAWN BY: DCM

DO NOT MODIFY OR SCALE DRAWING

PROJECT TITLE:

DESIGN: P.D.

SHEET NO: 8b

DRAWING & DESIGN REMAIN THE PROPERTY OF EUROPEAN WROUGHT IRON WORKS LTD.

FINISH: Custom

DRAWING NUMBER: RC-08b

REV 1- A

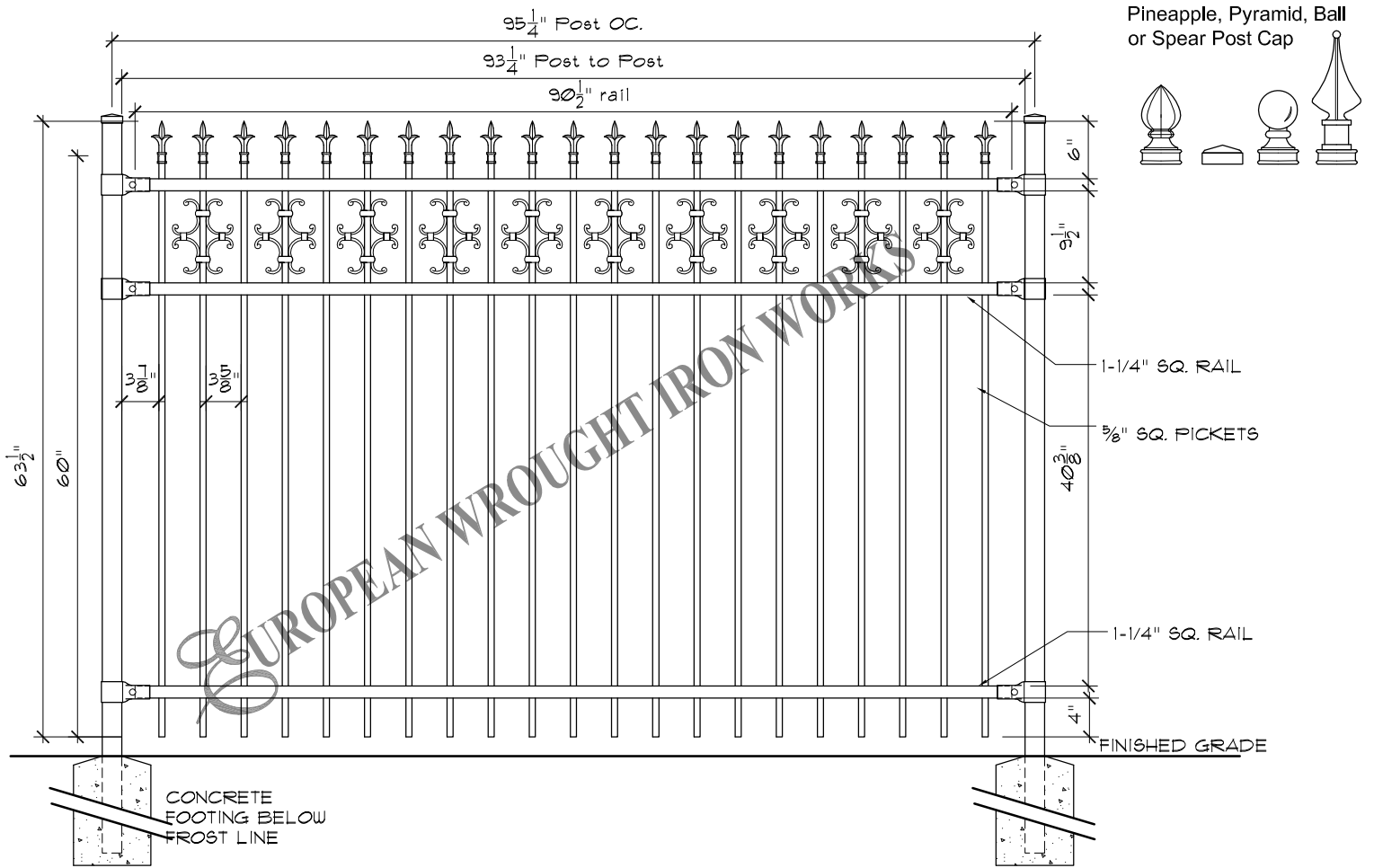

EUROPEAN WROUGHT IRON WORKS

TYPICAL RAIL SECTION

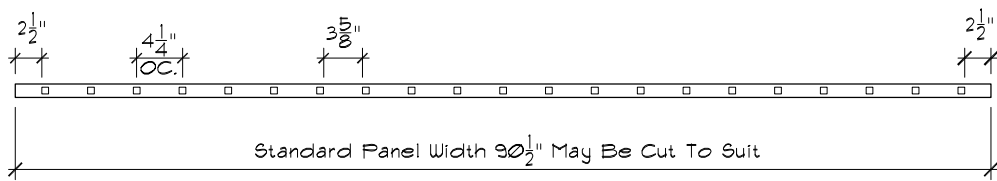
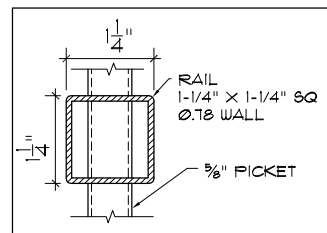

Specifications

<p>POST, RAILS & PICKETS: Cold Formed Steel Tubing Interior And Exterior Galvalume Coating Chromate Conversion Coating Electrostatically Applied Thermally Bonded Polyester Powder Coating Minimum Film Thickness 2.5 Mils</p> <p>POSTS: 2" x 2" (51mm x 51mm) 16 Gauge Standard Post Spacing 97-1/8" (2466mm) OC.</p> <p>POST CAP: Pyramid, Ball or Spear</p> <p>RAILS: 1-1/4" x 1-1/4" (32mm x 32mm) 14 Gauge</p> <p>PICKETS: 5/8" x 5/8" (15mm x 15mm) 16 Gauge</p>	<p>FITTINGS: 15 Gauge Stamp Forged Factory Finish. As Above</p> <p>WELDS: Stainless Steel</p> <p>STANDARD PANEL WIDTH: 91-1/2" (2324mm)</p> <p>AVAILABLE PANEL HEIGHTS: 48" (1219mm) (plus cap if applicable) 60" (1524mm) 72" (1828mm)</p> <p>NOTE: Tamper Proof Nut Available For Brackets</p> <p>COLOURS: Standard - High Gloss Black Optional Colours - Brown, Forest Green & Matt Black Custom Colours Available Upon Request.</p>
---	---

Information subject to change without notice

<p>The following note shall apply to all drawings and associated documents: 1. Copyright of this drawing and design is reserved by the Designer & European Wrought Iron Works Ltd. The drawing and all associated documents are an instrument of service by the Designer & European Wrought Iron Works Ltd. The drawing and the information contained therein may not be reproduced in whole or in part without prior written or verbal permission of the designer or European Wrought Iron Works Ltd. 2. Drawings are not to be scaled for construction. All existing site conditions and dimensions required to perform the work are to be verified and any discrepancies are to be reported to the designer & European Wrought Iron Works Ltd. 3. These drawings are not to be used for construction unless noted below as "Issued for Construction" 4. All work to be carried out in conformance with the Code and Bylaws of the authorities having jurisdiction. 5. The Designer of these plans and specifications gives no warranty or representation to any party about the constructability of the item represented by them.</p>	<p style="font-size: 8px;">CONFIDENTIAL: NOT TO BE DISCLOSED OR REPRODUCED</p> <p style="font-size: 8px;">WITHOUT THE WRITTEN PERMISSION OF EUROPEAN WROUGHT IRON WORKS LTD.</p>	<p>TOLERANCES INCHES UNLESS OTHERWISE NOTED ".XXX" ±0.005" ".X.X" ±0.05" ".X.X" ±0.25" FRACTIONAL ±1/16" ANGULAR ±1°</p>	<p>DO NOT MODIFY OR SCALE DRAWING</p>	<p>PROJECT TITLE:</p>	<p>DRAWING & DESIGN REMAIN THE PROPERTY OF EUROPEAN WROUGHT IRON WORKS LTD.</p>
<p>TITLE: Royalty Collection Emperor Custom with Casting</p>	<p>SCALE: NTS.</p> <p>DATE DRAWN: June 2015</p> <p>DRAWN BY: DCM</p>	<p>DESIGN: P.D.</p> <p>SHEET NO: 8c</p>	<p>FINISH: Custom</p> <p>DRAWING NUMBER: RC-08c</p>	<p>REV 1- A</p>	

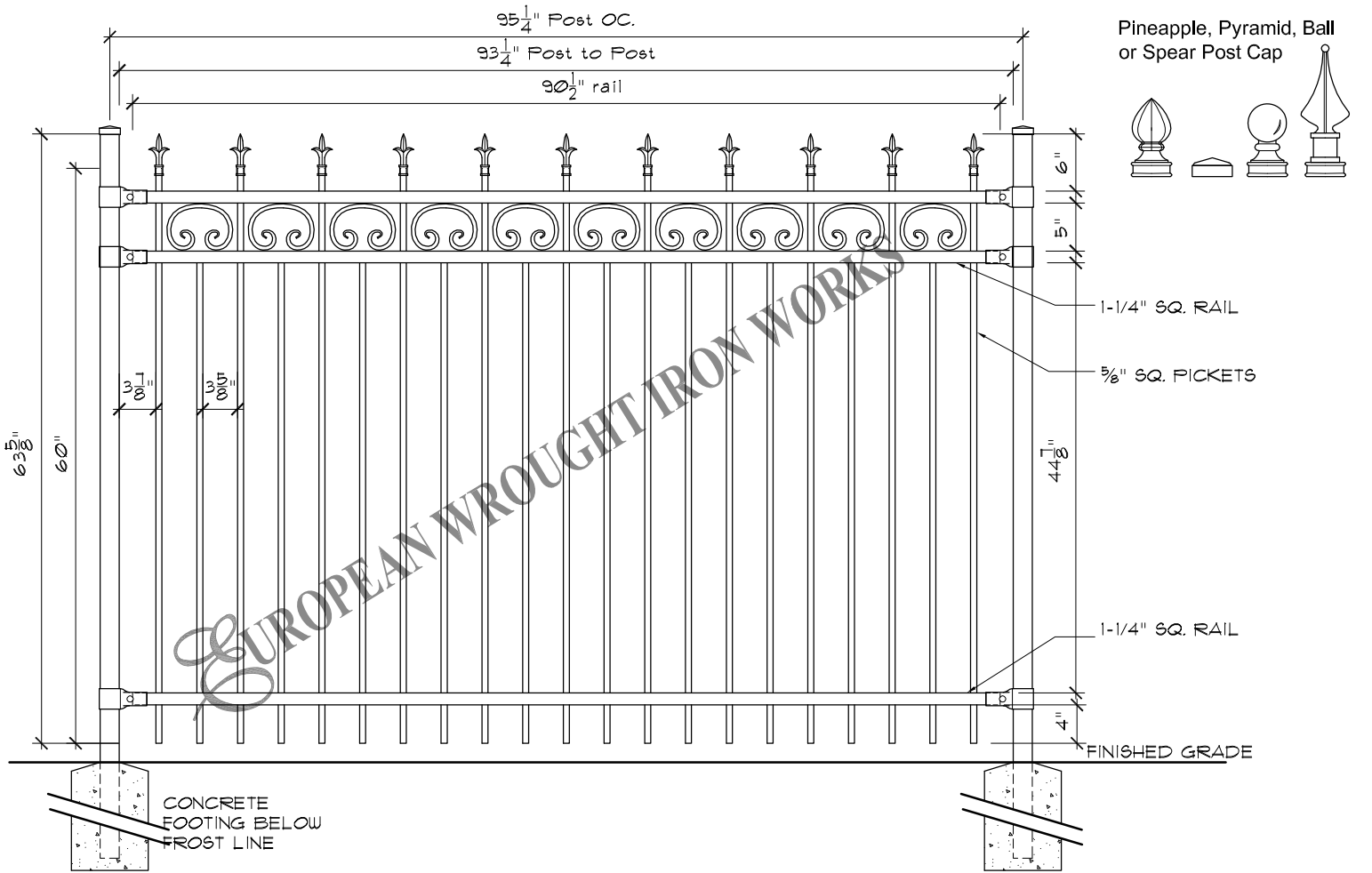

EUROPEAN WROUGHT IRON WORKS

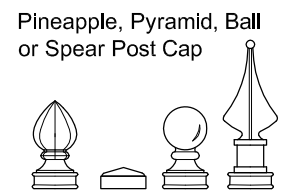

1-1/4" SQ. RAIL
5/8" SQ. PICKETS

1-1/4" SQ. RAIL

FINISHED GRADE

CONCRETE FOOTING BELOW FROST LINE

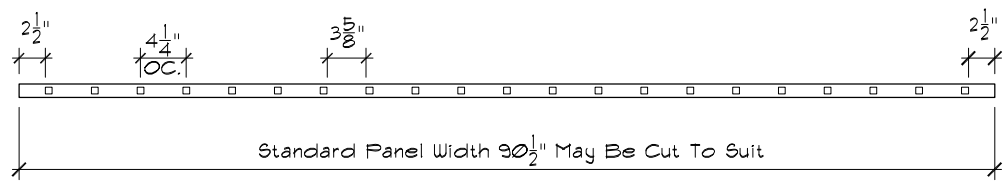

TYPICAL RAIL SECTION

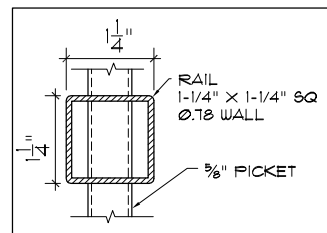

Specifications

<p>POST, RAILS & PICKETS: Cold Formed Steel Tubing Interior And Exterior Galvalume Coating Chromate Conversion Coating Electrostatically Applied Thermally Bonded Polyester Powder Coating Minimum Film Thickness 2.5 Mils</p> <p>POSTS: 2" x 2" (51mm x 51mm) 16 Gauge Standard Post Spacing 97-1/8" (2466mm) OC.</p> <p>POST CAP: Pyramid, Ball or Spear</p> <p>RAILS: 1-1/4" x 1-1/4" (32mm x 32mm) 14 Gauge</p> <p>PICKETS: 5/8" x 5/8" (15mm x 15mm) 16 Gauge</p>	<p>FITTINGS: 15 Gauge Stamp Forged Factory Finish. As Above</p> <p>WELDS: Stainless Steel</p> <p>STANDARD PANEL WIDTH: 91-1/2" (2324mm)</p> <p>AVAILABLE PANEL HEIGHTS: 48" (1219mm) (plus cap if applicable) 60" (1524mm) 72" (1828mm)</p> <p>NOTE: Tamper Proof Nut Available For Brackets</p> <p>COLOURS: Standard - High Gloss Black Optional Colours - Brown, Forest Green & Matt Black Custom Colours Available Upon Request.</p>
---	---

Information subject to change without notice

<p>The following note shall apply to all drawings and associated documents:</p> <p>1. Copyright of this drawing and design is reserved by the Designer & European Wrought Iron Works Ltd. The drawing and all associated documents are an instrument of service by the Designer & European Wrought Iron Works Ltd. The drawing and the information contained therein may not be reproduced in whole or in part without prior written or verbal permission of the designer or European Wrought Iron Works Ltd.</p> <p>2. Drawings are not to be scaled for construction. All existing site conditions and dimensions required to perform the work are to be verified and any discrepancies are to be reported to the designer & European Wrought Iron Works Ltd.</p> <p>3. These drawings are not to be used for construction unless noted below as "Issued for Construction"</p> <p>4. All work to be carried out in conformance with the Code and Bylaws of the authorities having jurisdiction.</p> <p>5. The Designer of these plans and specifications gives no warranty or representation to any party about the constructability of the item represented by them.</p>	<p style="font-size: 8px;">CONFIDENTIAL: NOT TO BE DISCLOSED OR REPRODUCED</p> <p style="font-size: 8px;">WITHOUT THE WRITTEN PERMISSION OF EUROPEAN WROUGHT IRON WORKS LTD.</p>	<p>TOLERANCES INCHES UNLESS OTHERWISE NOTED X.XXX" ±0.005" X.XX" ±0.05" X.X" ±0.25" FRACTIONAL ±1/16" ANGULAR ±1°</p>	<p>DO NOT MODIFY OR SCALE DRAWING</p>	<p>DRAWING & DESIGN REMAIN THE PROPERTY OF EUROPEAN WROUGHT IRON WORKS LTD.</p> <p>PROJECT TITLE:</p>		
<p>TITLE: Royalty Collection <i>Emperor Custom with Scroll</i></p>	<p>SCALE: NTS.</p> <p>DATE DRAWN: June 2015</p> <p>DRAWN BY: DCM</p>	<p>DESIGN: P.D.</p> <p>SHEET NO: 8d</p>	<p>FINISH: Custom</p> <p>DRAWING NUMBER: RC-08d</p>	<p>REV 1-</p>	<p>A</p>	

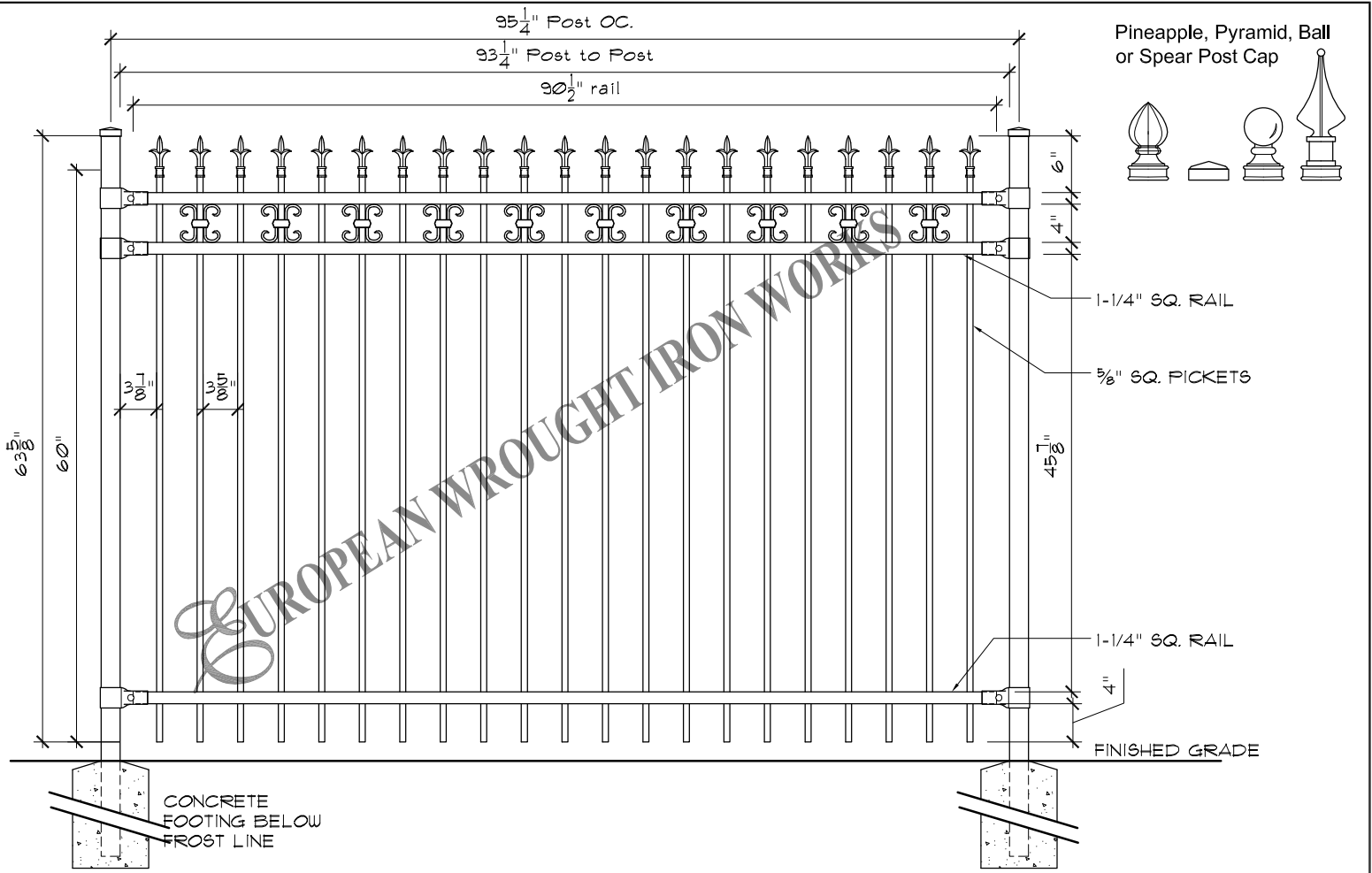

Pineapple, Pyramid, Ball or Spear Post Cap

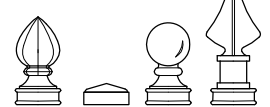

1-1/4" SQ. RAIL
5/8" SQ. PICKETS

1-1/4" SQ. RAIL
FINISHED GRADE

CONCRETE FOOTING BELOW FROST LINE

TYPICAL RAIL SECTION

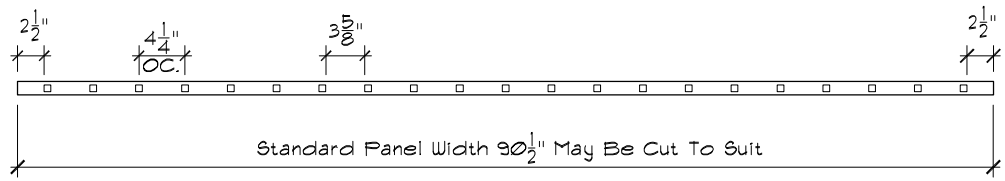
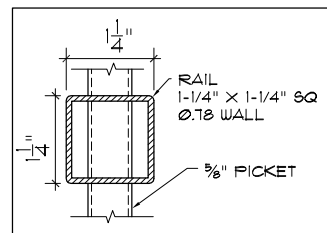

Specifications

POST, RAILS & PICKETS:	Cold Formed Steel Tubing Interior And Exterior Galvalume Coating Chromate Conversion Coating Electrostatically Applied Thermally Bonded Polyester Powder Coating Minimum Film Thickness 2.5 Mils	FITTINGS:	15 Gauge Stamp Forged Factory Finish. As Above
POSTS:	2" x 2" (51mm x 51mm) 16 Gauge Standard Post Spacing 97-1/8" (2466mm) OC.	WELDS:	Stainless Steel
POST CAP:	Pyramid, Ball or Spear	STANDARD PANEL WIDTH:	91-1/2" (2324mm)
RAILS:	1-1/4" x 1-1/4" (32mm x 32mm) 14 Gauge	AVAILABLE PANEL HEIGHTS:	48" (1219mm) (plus cap if applicable) 60" (1524mm) 72" (1828mm)
PICKETS:	5/8" x 5/8" (15mm x 15mm) 16 Gauge	NOTE:	Tamper Proof Nut Available For Brackets
		COLOURS:	Standard - High Gloss Black Optional Colours - Brown, Forest Green & Matt Black Custom Colours Available Upon Request.

Information subject to change without notice

<p>The following note shall apply to all drawings and associated documents:</p> <p>1. Copyright of this drawing and design is reserved by the Designer & European Wrought Iron Works Ltd. The drawing and all associated documents are an instrument of service by the Designer & European Wrought Iron Works Ltd. The drawing and the information contained therein may not be reproduced in whole or in part without prior written or verbal permission of the designer or European Wrought Iron Works Ltd.</p> <p>2. Drawings are not to be scaled for construction. All existing site conditions and dimensions required to perform the work are to be verified and any discrepancies are to be reported to the designer & European Wrought Iron Works Ltd.</p> <p>3. These drawings are not to be used for construction unless noted below as "Issued for Construction"</p> <p>4. All work to be carried out in conformance with the Code and Bylaws of the authorities having jurisdiction.</p> <p>5. The Designer of these plans and specifications gives no warranty or representation to any party about the constructability of the item represented by them.</p>	<p>CONFIDENTIAL: NOT TO BE DISCLOSED OR REPRODUCED</p> <p>WITHOUT THE WRITTEN PERMISSION OF EUROPEAN WROUGHT IRON WORKS LTD.</p>	<p>TOLERANCES INCHES UNLESS OTHERWISE NOTED X.XXX" ±0.005" X.XX" ±0.05" X.X" ±0.25" FRACTIONAL ±1/16" ANGULAR ±1°</p>	<p>DO NOT MODIFY OR SCALE DRAWING</p>	DRAWING & DESIGN REMAIN THE PROPERTY OF EUROPEAN WROUGHT IRON WORKS LTD.			
			<p>PROJECT TITLE:</p>	<p>DESIGN: P.D.</p>	<p>FINISH: Custom</p>	<p>SHEET NO: 8e</p>	<p>DRAWING NUMBER: RC-08e</p>
<p>TITLE: Royalty Collection Emperor Custom</p>		<p>SCALE: NTS.</p>	<p>DATE DRAWN: June 2015</p>	<p>DRAWN BY: DCM</p>			

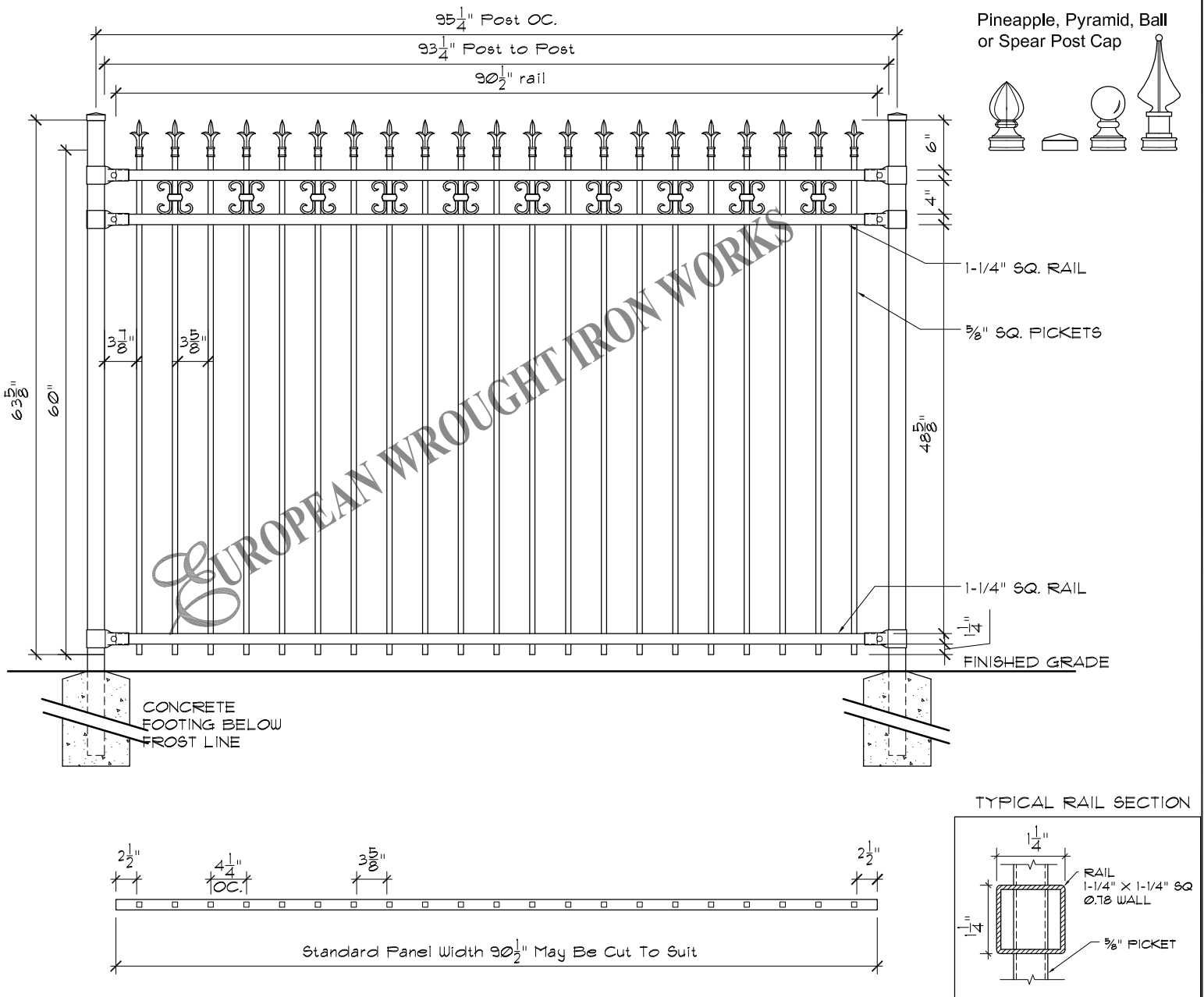

Specifications

POST, RAILS & PICKETS: Cold Formed Steel Tubing
Interior And Exterior Galvalume Coating
Chromate Conversion Coating
Electrostatically Applied
Thermally Bonded Polyester Powder Coating
Minimum Film Thickness 2.5 Mils

POSTS: 2" x 2" (51mm x 51mm) 16 Gauge
Standard Post Spacing 97-1/8" (2466mm) OC.

POST CAP: Pyramid, Ball or Spear

RAILS: 1-1/4" x 1-1/4" (32mm x 32mm) 14 Gauge

PICKETS: 5/8" x 5/8" (15mm x 15mm) 16 Gauge

FITTINGS: 15 Gauge Stamp Forged Factory Finish. As Above

WELDS: Stainless Steel

STANDARD PANEL WIDTH: 91-1/2" (2324mm)

AVAILABLE PANEL HEIGHTS: 48" (1219mm)
(plus cap if applicable)
60" (1524mm)
72" (1828mm)

NOTE: Tamper Proof Nut Available For Brackets

COLOURS: Standard - High Gloss Black
Optional Colours - Brown, Forest Green & Matt Black
Custom Colours Available Upon Request.

Information subject to change without notice

The following note shall apply to all drawings and associated documents:

- Copyright of this drawing and design is reserved by the Designer & European Wrought Iron Works Ltd. The drawing and all associated documents are an instrument of service by the Designer & European Wrought Iron Works Ltd. The drawing and the information contained therein may not be reproduced in whole or in part without prior written or verbal permission of the designer or European Wrought Iron Works Ltd.
- Drawings are not to be scaled for construction. All existing site conditions and dimensions required to perform the work are to be verified and any discrepancies are to be reported to the designer & European Wrought Iron Works Ltd.
- These drawings are not to be used for construction unless noted below as "Issued for Construction"
- All work to be carried out in conformance with the Code and Bylaws of the authorities having jurisdiction.
- The Designer of these plans and specifications gives no warranty or representation to any party about the constructability of the item represented by them.

CONFIDENTIAL: NOT TO BE DISCLOSED OR REPRODUCED

EUROPEAN
WROUGHT IRON WORKS

WITHOUT THE WRITTEN PERMISSION OF EUROPEAN WROUGHT IRON WORKS LTD.

TITLE:
Royalty Collection
Emperor Custom PS.

TOLERANCES
INCHES
UNLESS OTHERWISE NOTED
X.XXX" ±0.005"
X.XX" ±0.05"
X.X" ±0.25"
FRACTIONAL ±1/16"
ANGULAR ±1°

SCALE: NTS.

DATE DRAWN: June 2015

DRAWN BY: DCM

DO NOT MODIFY OR SCALE DRAWING

PROJECT TITLE:

DESIGN: P.D.

SHEET NO: 8f

DRAWING & DESIGN REMAIN THE PROPERTY OF EUROPEAN WROUGHT IRON WORKS LTD.

FINISH: Custom

DRAWING NUMBER: RC-08f

REV
1- A

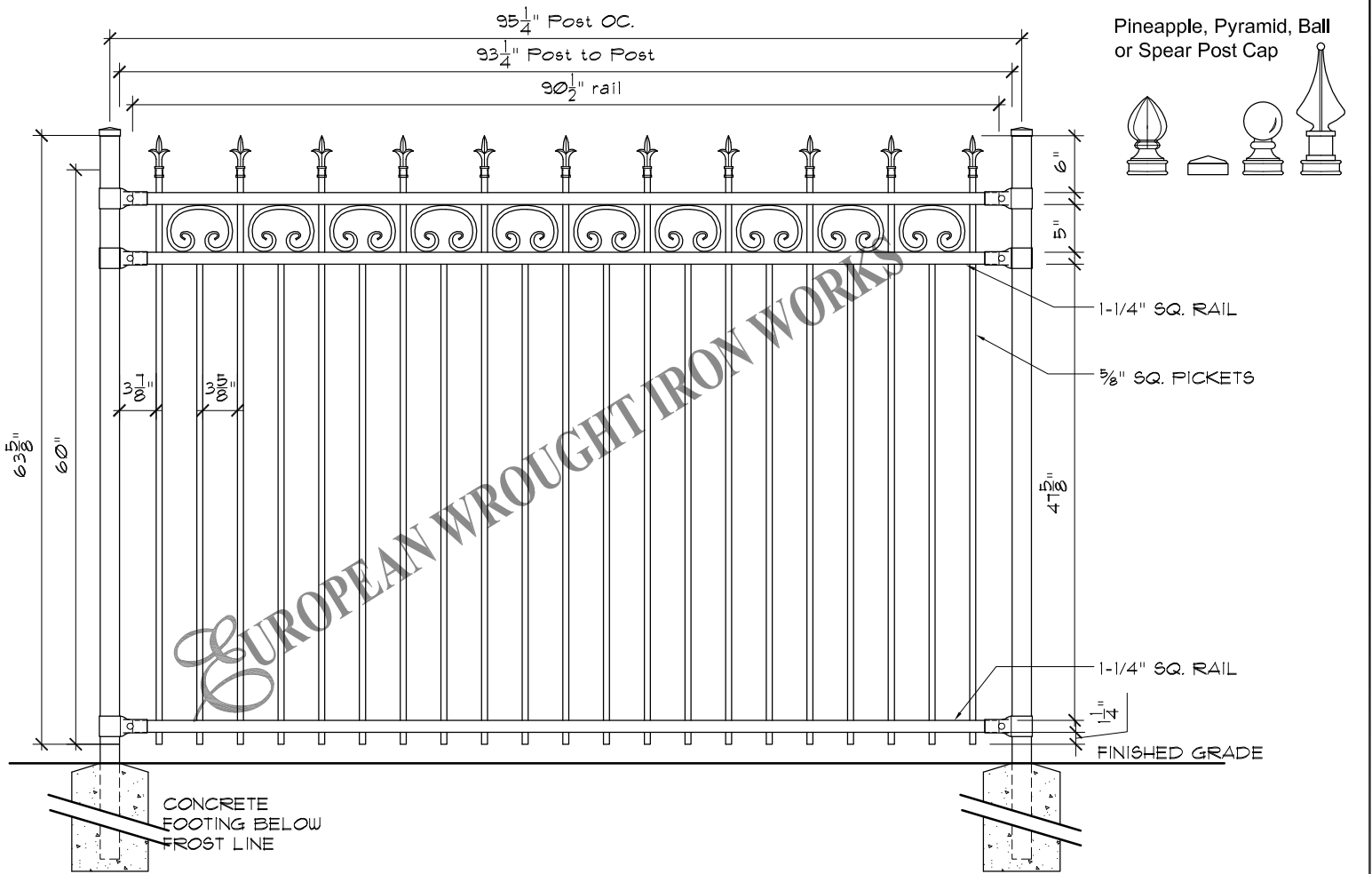

Pineapple, Pyramid, Ball or Spear Post Cap

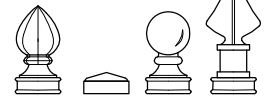

EUROPEAN WROUGHT IRON WORKS

TYPICAL RAIL SECTION

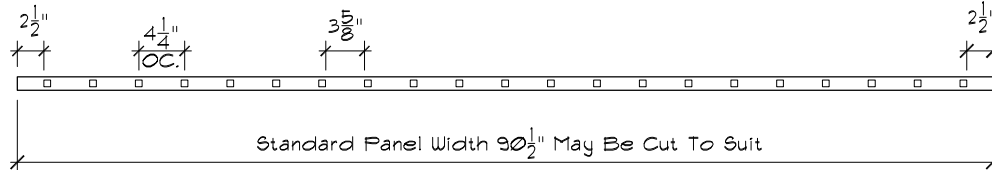
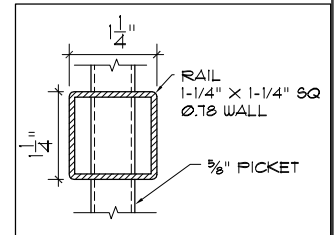

Specifications

<p>POST, RAILS & PICKETS: Cold Formed Steel Tubing Interior And Exterior Galvalume Coating Chromate Conversion Coating Electrostatically Applied Thermally Bonded Polyester Powder Coating Minimum Film Thickness 2.5 Mils</p> <p>POSTS: 2" x 2" (51mm x 51mm) 16 Gauge Standard Post Spacing 97-1/8" (2466mm) OC.</p> <p>POST CAP: Pyramid, Ball or Spear</p> <p>RAILS: 1-1/4" x 1-1/4" (32mm x 32mm) 14 Gauge</p> <p>PICKETS: 5/8" x 5/8" (15mm x 15mm) 16 Gauge</p>	<p>FITTINGS: 15 Gauge Stamp Forged Factory Finish. As Above</p> <p>WELDS: Stainless Steel</p> <p>STANDARD PANEL WIDTH: 91-1/2" (2324mm)</p> <p>AVAILABLE PANEL HEIGHTS: 48" (1219mm) (plus cap if applicable) 60" (1524mm) 72" (1828mm)</p> <p>NOTE: Tamper Proof Nut Available For Brackets</p> <p>COLOURS: Standard - High Gloss Black Optional Colours - Brown, Forest Green & Matt Black Custom Colours Available Upon Request.</p>
---	---

Information subject to change without notice

The following note shall apply to all drawings and associated documents:
 1. Copyright of this drawing and design is reserved by the Designer & European Wrought Iron Works Ltd. The drawing and all associated documents are an instrument of service by the Designer & European Wrought Iron Works Ltd. The drawing and the information contained therein may not be reproduced in whole or in part without prior written or verbal permission of the designer or European Wrought Iron Works Ltd.
 2. Drawings are not to be scaled for construction. All existing site conditions and dimensions required to perform the work are to be verified and any discrepancies are to be reported to the designer & European Wrought Iron Works Ltd.
 3. These drawings are not to be used for construction unless noted below as "Issued for Construction"
 4. All work to be carried out in conformance with the Code and Bylaws of the authorities having jurisdiction.
 5. The Designer of these plans and specifications gives no warranty or representation to any party about the constructability of the item represented by them.

CONFIDENTIAL: NOT TO BE DISCLOSED OR REPRODUCED



ROYALTY COLLECTION
Emperor Custom with Scrolls PS.

WITHOUT THE WRITTEN PERMISSION OF EUROPEAN WROUGHT IRON WORKS LTD.

TITLE: **Royalty Collection**
Emperor Custom with Scrolls PS.

TOLERANCES INCHES UNLESS OTHERWISE NOTED X.XXX" ±0.005" X.XX" ±0.05" X.X" ±0.25" FRACTIONAL ±1/16" ANGULAR ±1°	SCALE: NTS.	DATE DRAWN: June 2015	DRAWN BY: DCM
---	-------------	-----------------------	---------------

DO NOT MODIFY OR SCALE DRAWING	PROJECT TITLE:
DESIGN: P.D.	SHEET NO: 8g

DRAWING & DESIGN REMAIN THE PROPERTY OF EUROPEAN WROUGHT IRON WORKS LTD.	FINISH: Custom	REV 1-	A
DRAWING NUMBER: RC-08g			

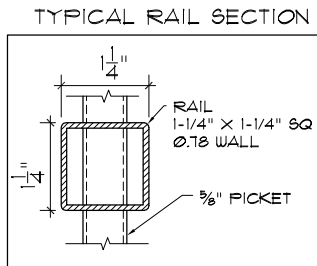
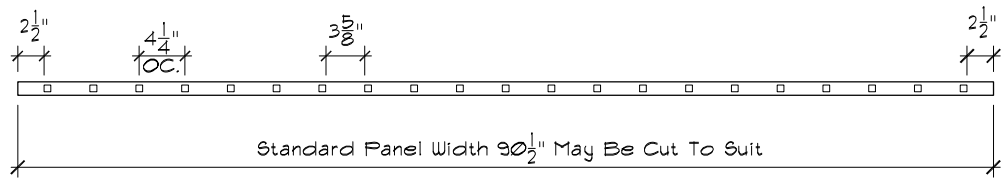
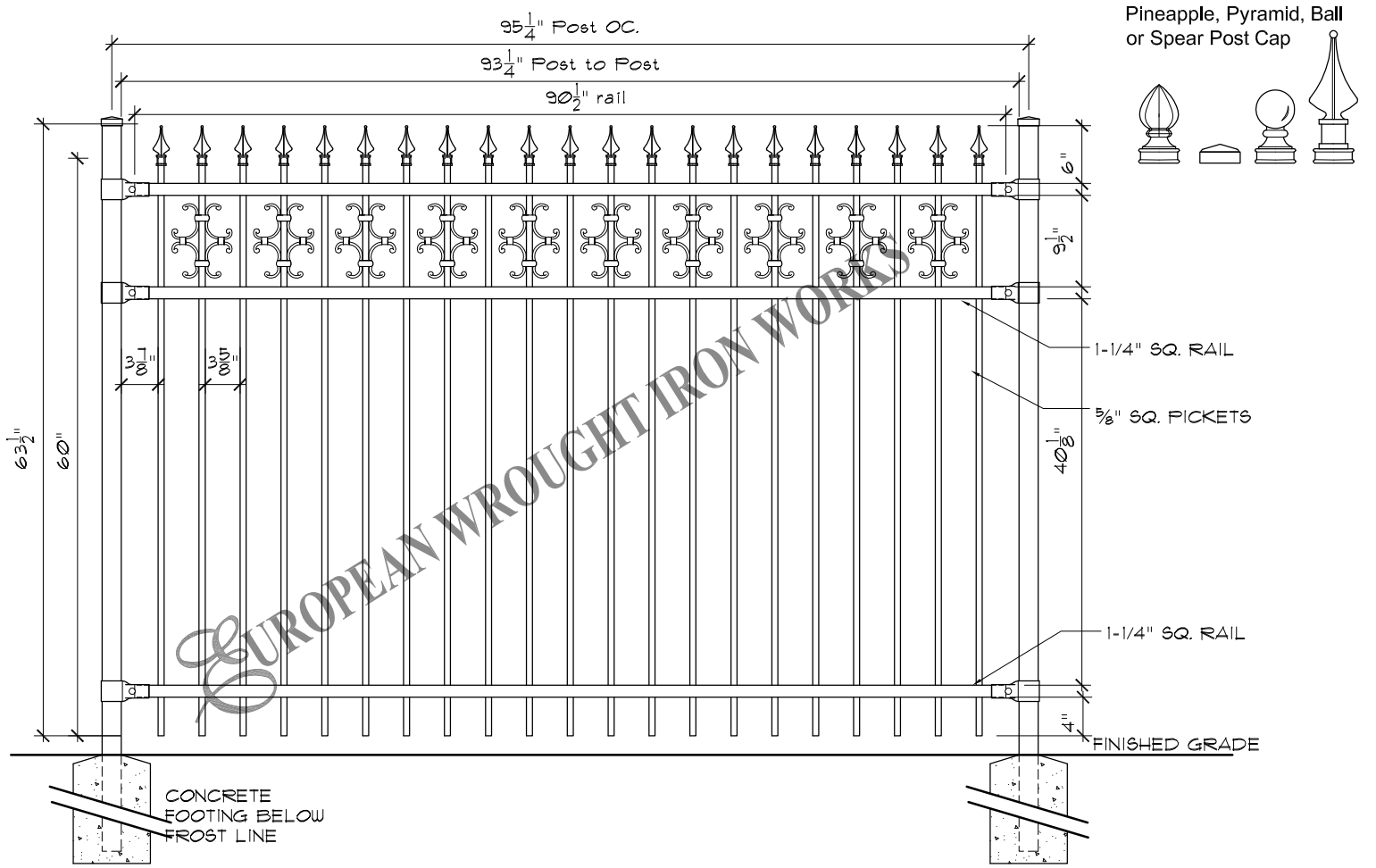

Specifications

<p>POST, RAILS & PICKETS: Cold Formed Steel Tubing Interior And Exterior Galvalume Coating Chromate Conversion Coating Electrostatically Applied Thermally Bonded Polyester Powder Coating Minimum Film Thickness 2.5 Mils</p> <p>POSTS: 2" x 2" (51mm x 51mm) 16 Gauge Standard Post Spacing 97-1/8" (2466mm) OC.</p> <p>POST CAP: Pyramid, Ball or Spear</p> <p>RAILS: 1-1/4" x 1-1/4" (32mm x 32mm) 14 Gauge</p> <p>PICKETS: 5/8" x 5/8" (15mm x 15mm) 16 Gauge</p>	<p>FITTINGS: 15 Gauge Stamp Forged Factory Finish. As Above</p> <p>WELDS: Stainless Steel</p> <p>STANDARD PANEL WIDTH: 91-1/2" (2324mm)</p> <p>AVAILABLE PANEL HEIGHTS: 48" (1219mm) (plus cap if applicable) 60" (1524mm) 72" (1828mm)</p> <p>NOTE: Tamper Proof Nut Available For Brackets</p> <p>COLOURS: Standard - High Gloss Black Optional Colours - Brown, Forest Green & Matt Black Custom Colours Available Upon Request.</p>
---	---

Information subject to change without notice

<p>The following note shall apply to all drawings and associated documents:</p> <p>1. Copyright of this drawing and design is reserved by the Designer & European Wrought Iron Works Ltd. The drawing and all associated documents are an instrument of service by the Designer & European Wrought Iron Works Ltd. The drawing and the information contained therein may not be reproduced in whole or in part without prior written or verbal permission of the designer or European Wrought Iron Works Ltd.</p> <p>2. Drawings are not to be scaled for construction. All existing site conditions and dimensions required to perform the work are to be verified and any discrepancies are to be reported to the designer & European Wrought Iron Works Ltd.</p> <p>3. These drawings are not to be used for construction unless noted below as "Issued for Construction"</p> <p>4. All work to be carried out in conformance with the Code and Bylaws of the authorities having jurisdiction.</p> <p>5. The Designer of these plans and specifications gives no warranty or representation to any party about the constructability of the item represented by them.</p>	<p style="font-size: 8px;">CONFIDENTIAL: NOT TO BE DISCLOSED OR REPRODUCED</p> <p style="font-size: 8px;">WITHOUT THE WRITTEN PERMISSION OF EUROPEAN WROUGHT IRON WORKS LTD.</p>	<p>TOLERANCES UNLESS OTHERWISE NOTED</p> <p>INCHES X.XXX" ±0.005" X.XX" ±0.05" X.X" ±0.25" FRACTIONAL ±1/16" ANGULAR ±1°</p>	<p>DO NOT MODIFY OR SCALE DRAWING</p> <p>PROJECT TITLE:</p>	<p>DRAWING & DESIGN REMAIN THE PROPERTY OF EUROPEAN WROUGHT IRON WORKS LTD.</p>	<p>SCALE: NTS.</p> <p>DATE DRAWN: June 2015</p> <p>DRAWN BY: DCM</p>	<p>DESIGN: P.D.</p> <p>SHEET NO: 8h</p>	<p>FINISH: Custom</p> <p>DRAWING NUMBER: RC-08g</p>	<p>REV 1-</p>	<p>A</p>
<p>TITLE: Royalty Collection <i>Emperor Custom with Scrolls.</i></p>									

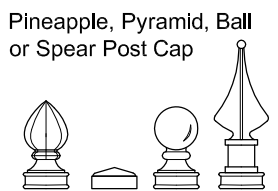
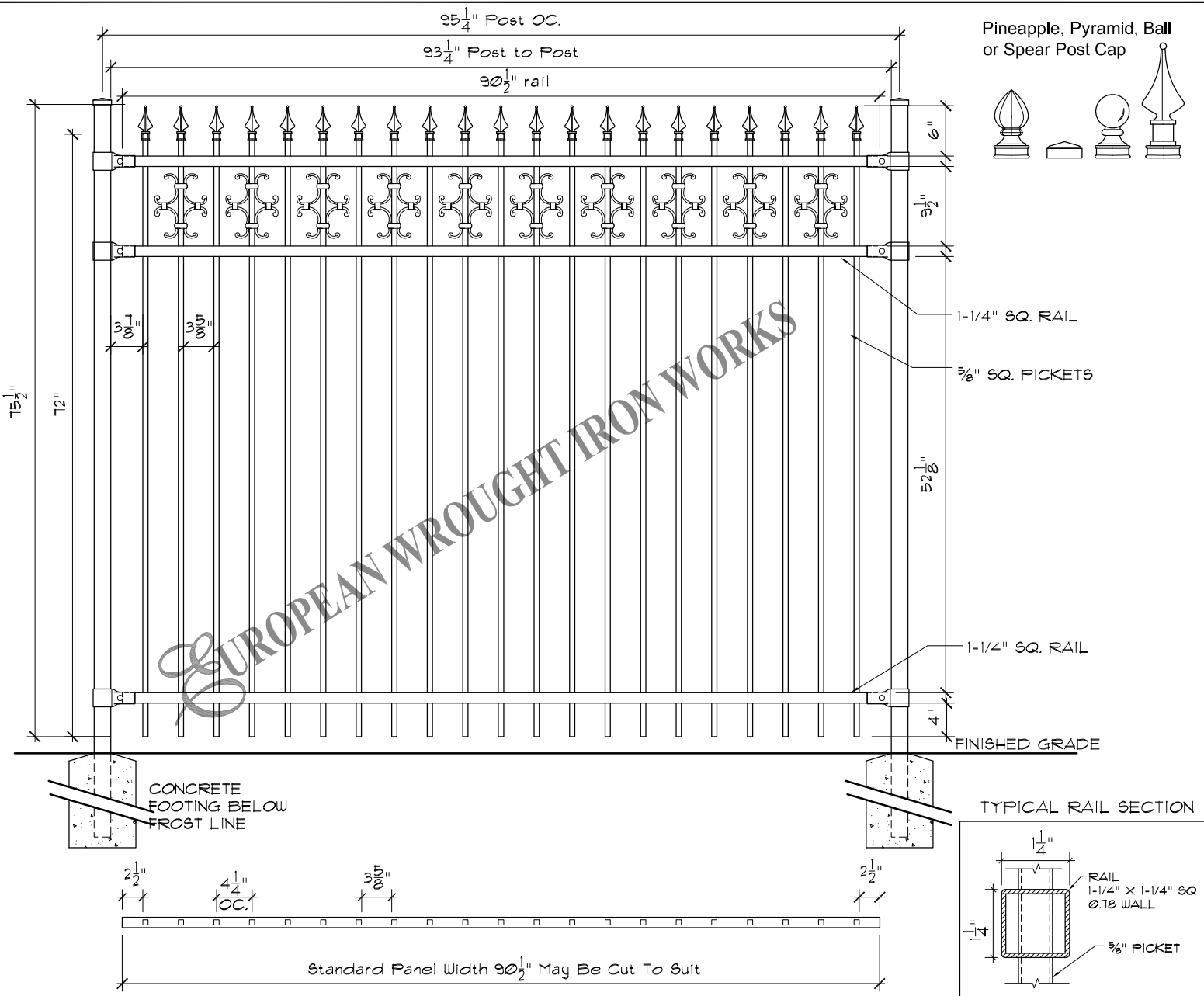

Specifications

POST, RAILS & PICKETS:	Cold Formed Steel Tubing Interior And Exterior Galvalume Coating Chromate Conversion Coating Electrostatically Applied Thermally Bonded Polyester Powder Coating Minimum Film Thickness 2.5 Mils	FITTINGS:	15 Gauge Stamp Forged Factory Finish. As Above
POSTS:	2" x 2" (51mm x 51mm) 16 Gauge Standard Post Spacing 97-1/8" (2466mm) OC.	WELDS:	Stainless Steel
POST CAP:	Pyramid, Ball or Spear	STANDARD PANEL WIDTH:	91-1/2" (2324mm)
RAILS:	1-1/4" x 1-1/4" (32mm x 32mm) 14 Gauge	AVAILABLE PANEL HEIGHTS:	48" (1219mm) (plus cap if applicable) 60" (1524mm) 72" (1828mm)
PICKETS:	5/8" x 5/8" (15mm x 15mm) 16 Gauge	NOTE:	Tamper Proof Nut Available For Brackets
		COLOURS:	Standard - High Gloss Black Optional Colours - Brown, Forest Green & Matt Black Custom Colours Available Upon Request.

Information subject to change without notice

<p>The following note shall apply to all drawings and associated documents:</p> <p>1. Copyright of this drawing and design is reserved by the Designer & European Wrought Iron Works Ltd. The drawing and all associated documents are an instrument of service by the Designer & European Wrought Iron Works Ltd. The drawing and the information contained therein may not be reproduced in whole or in part without prior written or verbal permission of the designer or European Wrought Iron Works Ltd.</p> <p>2. Drawings are not to be scaled for construction. All existing site conditions and dimensions required to perform the work are to be verified and any discrepancies are to be reported to the designer & European Wrought Iron Works Ltd.</p> <p>3. These drawings are not to be used for construction unless noted below as "Issued for Construction"</p> <p>4. All work to be carried out in conformance with the Code and Bylaws of the authorities having jurisdiction.</p> <p>5. The Designer of these plans and specifications gives no warranty or representation to any party about the constructability of the item represented by them.</p>	<p>CONFIDENTIAL: NOT TO BE DISCLOSED OR REPRODUCED</p> <p>WITHOUT THE WRITTEN PERMISSION OF EUROPEAN WROUGHT IRON WORKS LTD.</p>		<p>TOLERANCES INCHES UNLESS OTHERWISE NOTED X.XXX" ±0.005" X.XX" ±0.05" X.X" ±0.25" FRACTIONAL ±1/16" ANGULAR ±1°</p>		<p>DO NOT MODIFY OR SCALE DRAWING</p>		<p>DRAWING & DESIGN REMAIN THE PROPERTY OF EUROPEAN WROUGHT IRON WORKS LTD.</p>	
	<p>TITLE: Royalty Collection <i>Emperor Custom with Scrolls PS.</i></p>		<p>SCALE: NTS.</p>	<p>DESIGN: P.D.</p>	<p>FINISH: Custom</p>		<p>PROJECT TITLE:</p>	
<p>DATE DRAWN: June 2015</p> <p>DRAWN BY: DCM</p>		<p>SHEET NO: 8i</p>	<p>DRAWING NUMBER: RC-08g</p>		<p>REV: 1-</p>	<p>A</p>		

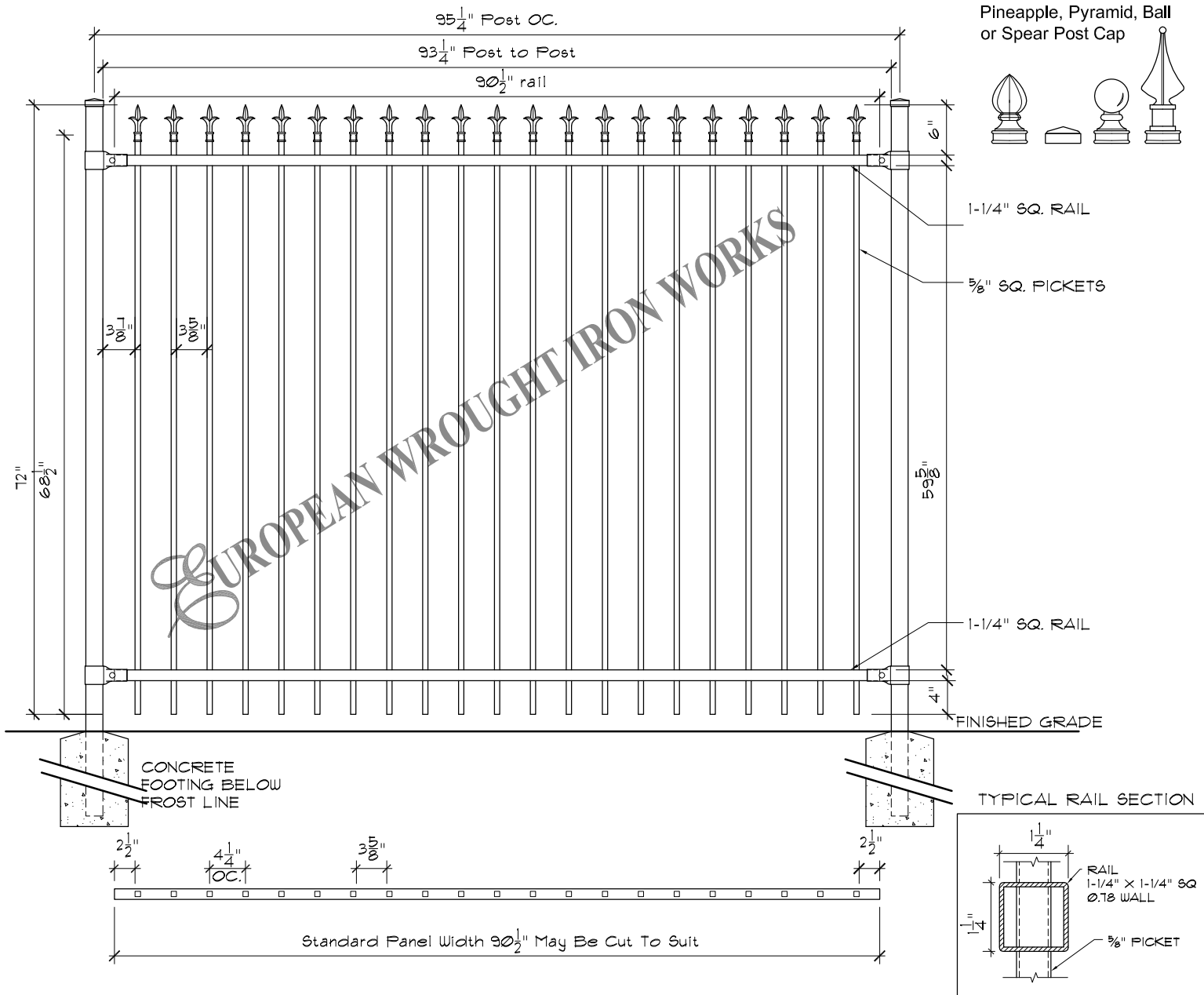

Pineapple, Pyramid, Ball or Spear Post Cap

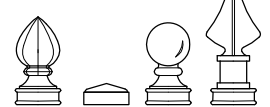

Specifications

<p>POST, RAILS & PICKETS: Cold Formed Steel Tubing Interior And Exterior Galvalume Coating Chromate Conversion Coating Electrostatically Applied Thermally Bonded Polyester Powder Coating Minimum Film Thickness 2.5 Mils</p> <p>POSTS: 2" x 2" (51mm x 51mm) 16 Gauge Standard Post Spacing 97-1/8" (2466mm) OC.</p> <p>POST CAP: Pyramid, Ball or Spear</p> <p>RAILS: 1-1/4" x 1-1/4" (32mm x 32mm) 14 Gauge</p> <p>PICKETS: 5/8" x 5/8" (15mm x 15mm) 16 Gauge</p>	<p>FITTINGS: 15 Gauge Stamp Forged Factory Finish. As Above</p> <p>WELDS: Stainless Steel</p> <p>STANDARD PANEL WIDTH: 91-1/2" (2324m)</p> <p>AVAILABLE PANEL HEIGHTS: 48" (1219mm) (plus cap if applicable) 60" (1524mm) 72" (1828mm)</p> <p>NOTE: Tamper Proof Nut Available For Brackets</p> <p>COLOURS: Standard - High Gloss Black Optional Colours - Brown, Forest Green & Matt Black Custom Colours Available Upon Request.</p>
---	--

Information subject to change without notice

<p>The following note shall apply to all drawings and associated documents:</p> <p>1. Copyright of this drawing and design is reserved by the Designer & European Wrought Iron Works Ltd. The drawing and all associated documents are an instrument of service by the Designer & European Wrought Iron Works Ltd. The drawing and the information contained therein may not be reproduced in whole or in part without prior written or verbal permission of the designer or European Wrought Iron Works Ltd.</p> <p>2. Drawings are not to be scaled for construction. All existing site conditions and dimensions required to perform the work are to be verified and any discrepancies are to be reported to the designer & European Wrought Iron Works Ltd.</p> <p>3. These drawings are not to be used for construction unless noted below as "Issued for Construction"</p> <p>4. All work to be carried out in conformance with the Code and Bylaws of the authorities having jurisdiction.</p> <p>5. The Designer of these plans and specifications gives no warranty or representation to any party about the constructability of the item represented by them.</p>	<p style="font-size: 8px;">CONFIDENTIAL: NOT TO BE DISCLOSED OR REPRODUCED</p> <p style="font-size: 8px;">WITHOUT THE WRITTEN PERMISSION OF EUROPEAN WROUGHT IRON WORKS LTD.</p>	<p>TOLERANCES INCHES UNLESS OTHERWISE NOTED X.XXX" ±0.005" X.XX" ±0.05" X.X" ±0.25" FRACTIONAL ±1/16" ANGULAR ±1°</p>	<p>DO NOT MODIFY OR SCALE DRAWING</p>	<p>PROJECT TITLE:</p>	<p>DRAWING & DESIGN REMAIN THE PROPERTY OF EUROPEAN WROUGHT IRON WORKS LTD.</p>
<p>TITLE: Royalty Collection <i>Emperor 6ft</i></p>	<p>SCALE: NTS.</p> <p>DATE DRAWN: May 2024</p> <p>DRAWN BY: DCM</p>	<p>DESIGN: P.D.</p> <p>SHEET NO: 8j</p>	<p>FINISH: Custom</p> <p>DRAWING NUMBER: RC-08g</p>	<p>REV 1- A</p>	

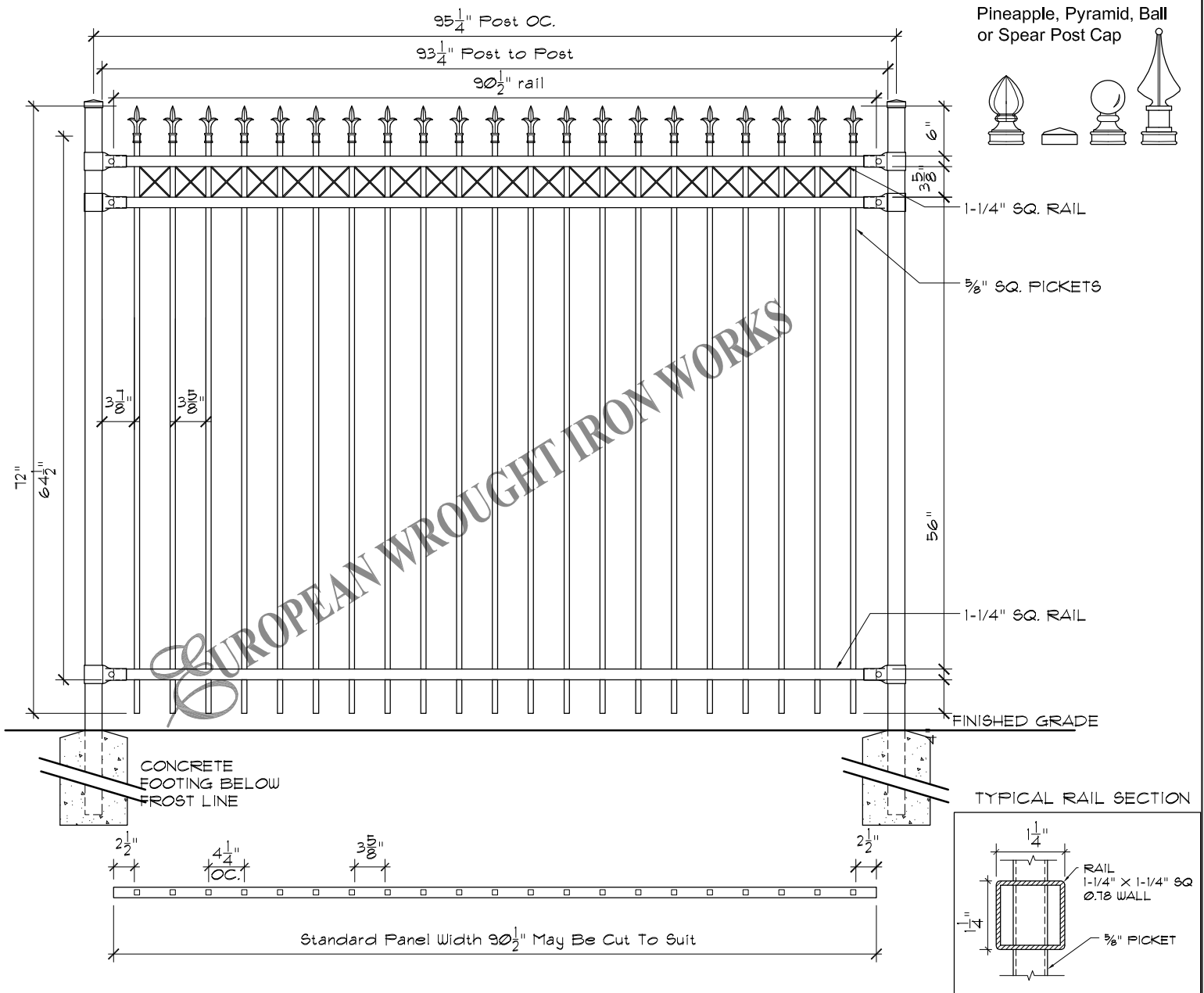

Specifications

POST, RAILS & PICKETS:	Cold Formed Steel Tubing Interior And Exterior Galvalume Coating Chromate Conversion Coating Electrostatically Applied Thermally Bonded Polyester Powder Coating Minimum Film Thickness 2.5 Mils	FITTINGS:	15 Gauge Stamp Forged Factory Finish. As Above
POSTS:	2" x 2" (51mm x 51mm) 16 Gauge Standard Post Spacing 97-1/8" (2466mm) OC.	WELDS:	Stainless Steel
POST CAP:	Pyramid, Ball or Spear	STANDARD PANEL WIDTH:	91-1/2" (2324mm)
RAILS:	1-1/4" x 1-1/4" (32mm x 32mm) 14 Gauge	AVAILABLE PANEL HEIGHTS:	48" (1219mm) (plus cap if applicable) 60" (1524mm) 72" (1828mm)
PICKETS:	5/8" x 5/8" (15mm x 15mm) 16 Gauge	NOTE:	Tamper Proof Nut Available For Brackets
		COLOURS:	Standard - High Gloss Black Optional Colours - Brown, Forest Green & Matt Black Custom Colours Available Upon Request.

Information subject to change without notice

The following note shall apply to all drawings and associated documents:
1. Copyright of this drawing and design is reserved by the Designer & European Wrought Iron Works Ltd. The drawing and all associated documents are an instrument of service by the Designer & European Wrought Iron Works Ltd. The drawing and the information contained therein may not be reproduced in whole or in part without prior written or verbal permission of the designer or European Wrought Iron Works Ltd.
2. Drawings are not to be scaled for construction. All existing site conditions and dimensions required to perform the work are to be verified and any discrepancies are to be reported to the designer & European Wrought Iron Works Ltd.
3. These drawings are not to be used for construction unless noted below as "Issued for Construction"
4. All work to be carried out in conformance with the Code and Bylaws of the authorities having jurisdiction.
5. The Designer of these plans and specifications gives no warranty or representation to any party about the constructability of the item represented by them.

CONFIDENTIAL: NOT TO BE DISCLOSED OR REPRODUCED

WITHOUT THE WRITTEN PERMISSION OF EUROPEAN WROUGHT IRON WORKS LTD.

TITLE: **Royalty Collection**
Emperor 6ft

TOLERANCES INCHES UNLESS OTHERWISE NOTED
X.XXX" ±0.005"
X.XX" ±0.05"
X.X" ±0.25"
FRACTIONAL ±1/16"
ANGULAR ±1°

SCALE: NTS.

DATE DRAWN: May 2024

DRAWN BY: DCM

DO NOT MODIFY OR SCALE DRAWING

PROJECT TITLE:

DESIGN: P.D.

SHEET NO: 8k

DRAWING & DESIGN REMAIN THE PROPERTY OF EUROPEAN WROUGHT IRON WORKS LTD.

FINISH: Custom

DRAWING NUMBER: RC-08g

REV 1- A

Pineapple, Pyramid, Ball or Spear Post Cap

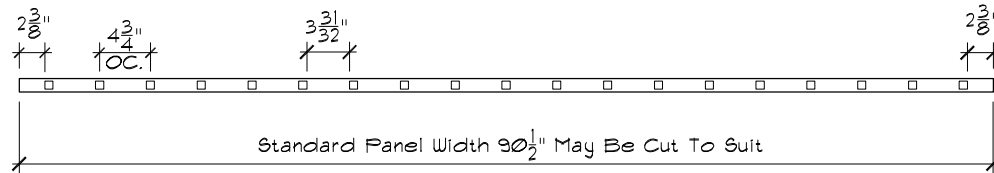
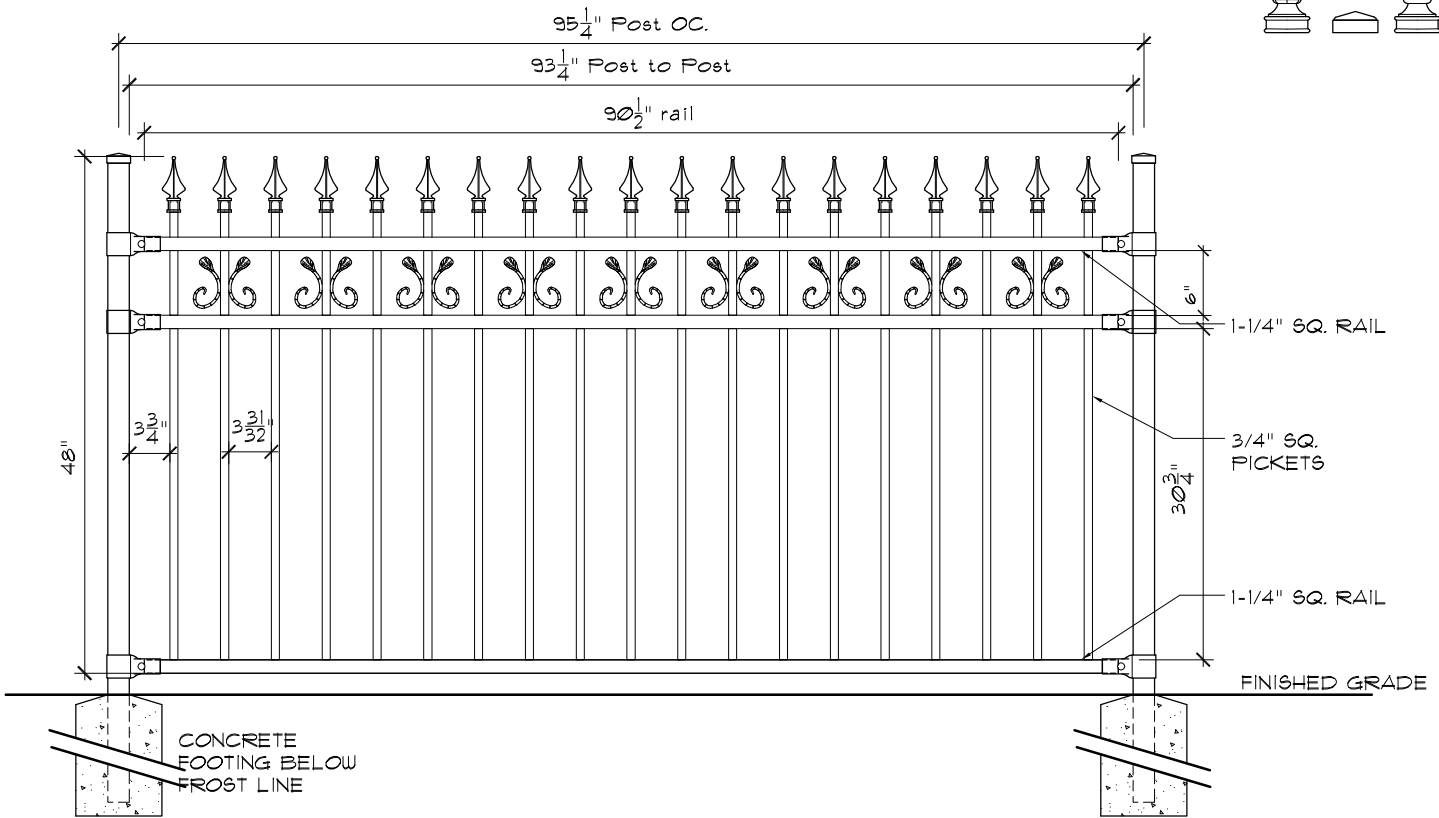
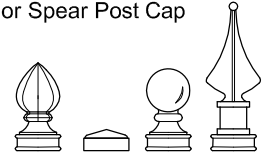

TYPICAL RAIL SECTION

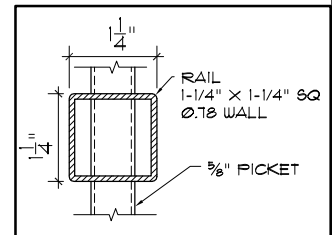

Specifications

POST, RAILS & PICKETS:	Cold Formed Steel Tubing Interior And Exterior Galvalume Coating Chromate Conversion Coating Electrostatically Applied Thermally Bonded Polyester Powder Coating Minimum Film Thickness 2.5 Mils	FITTINGS:	15 Gauge Stamp Forged Factory Finish. As Above
POSTS:	2" x 2" (51mm x 51mm) 16 Gauge Standard Post Spacing 97-1/8" (2466mm) OC.	WELDS:	Stainless Steel
POST CAP:	Pyramid, Ball or Spear	STANDARD PANEL WIDTH:	91-1/2" (2324mm)
RAILS:	1-1/4" x 1-1/4" (32mm x 32mm) 14 Gauge	AVAILABLE PANEL HEIGHTS:	48" (1219mm) (plus cap if applicable) 60" (1524mm) 72" (1828mm)
PICKETS:	5/8" x 5/8" (15mm x 15mm) 16 Gauge	NOTE:	Tamper Proof Nut Available For Brackets
		COLOURS:	Standard - High Gloss Black Optional Colours - Brown, Forest Green & Matt Black Custom Colours Available Upon Request.

The following note shall apply to all drawings and associated documents:

- Copyright of this drawing and design is reserved by the Designer & European Wrought Iron Works Ltd. The drawing and all associated documents are an instrument of service by the Designer & European Wrought Iron Works Ltd. The drawing and the information contained therein may not be reproduced in whole or in part without prior written or verbal permission of the designer or European Wrought Iron Works Ltd.
- Drawings are not to be scaled for construction. All existing site conditions and dimensions required to perform the work are to be verified and any discrepancies are to be reported to the designer & European Wrought Iron Works Ltd.
- These drawings are not to be used for construction unless noted below as "Issued for Construction"
- All work to be carried out in conformance with the Code and Bylaws of the authorities having jurisdiction.
- The Designer of these plans and specifications gives no warranty or representation to any party about the constructability of the item represented by them.

CONFIDENTIAL: NOT TO BE DISCLOSED OR REPRODUCED



TITLE: **Royalty Collection**
3/4" Prince

TOLERANCES INCHES UNLESS OTHERWISE NOTED
X.XXX" ±0.005"
X.XX" ±0.05"
X.X" ±0.25"
FRACTIONAL ±1/16"
ANGULAR ±1°

SCALE: NTS.
DATE DRAWN: Aug 2017
DRAWN BY: DCM

DO NOT MODIFY OR SCALE DRAWING

PROJECT TITLE:

DRAWING & DESIGN REMAIN THE PROPERTY OF EUROPEAN WROUGHT IRON WORKS LTD.

DESIGN: P.D.
SHEET NO: 12sc1

FINISH: Custom
DRAWING NUMBER: RC-12

REV 1- A

Pineapple, Pyramid, Ball or Spear Post Cap

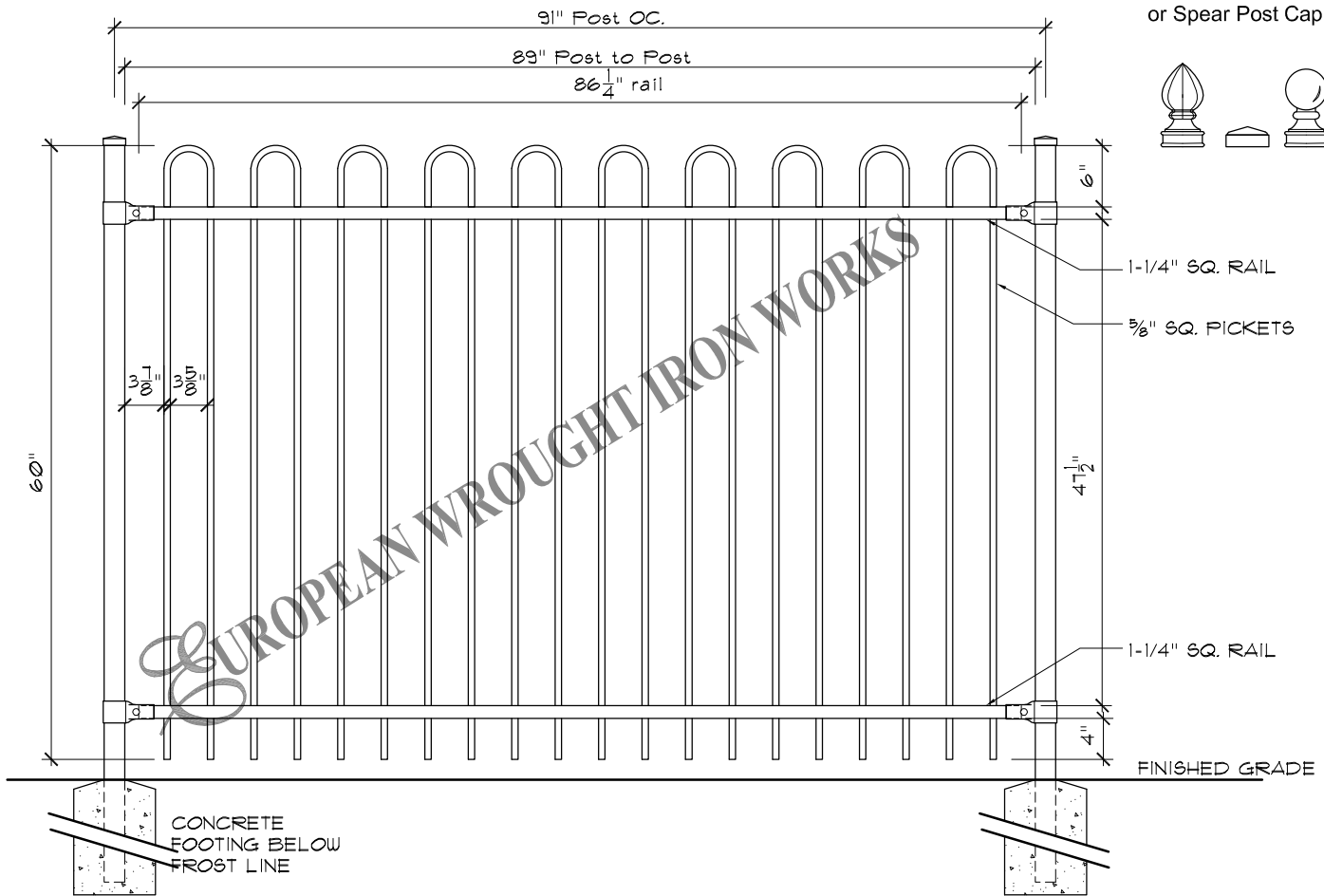
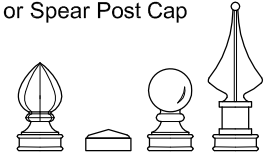

EUROPEAN WROUGHT IRON WORKS

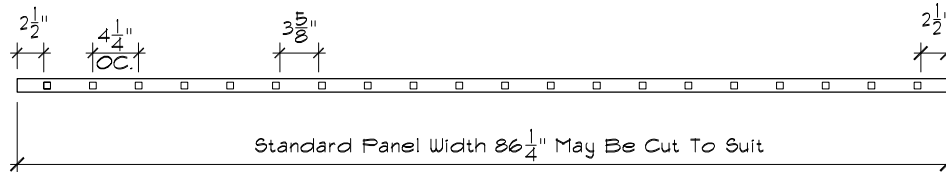

TYPICAL RAIL SECTION

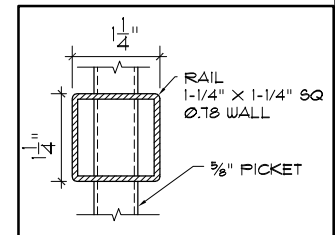

Specifications

<p>POST, RAILS & PICKETS: Cold Formed Steel Tubing Interior And Exterior Galvalume Coating Chromate Conversion Coating Electrostatically Applied Thermally Bonded Polyester Powder Coating Minimum Film Thickness 2.5 Mils</p> <p>POSTS: 2" x 2" (51mm x 51mm) 16 Gauge Standard Post Spacing 97-1/8" (2466mm) OC.</p> <p>POST CAP: Pyramid, Ball or Spear</p> <p>RAILS: 1-1/4" x 1-1/4" (32mm x 32mm) 14 Gauge</p> <p>PICKETS: 5/8" x 5/8" (15mm x 15mm) 16 Gauge</p>	<p>FITTINGS: 15 Gauge Stamp Forged Factory Finish. As Above</p> <p>WELDS: Stainless Steel</p> <p>STANDARD PANEL WIDTH: 86-1/4" (2190mm)</p> <p>AVAILABLE PANEL HEIGHTS: 48" (1219mm) (plus cap if applicable) 60" (1524mm) 72" (1828mm)</p> <p>NOTE: Tamper Proof Nut Available For Brackets</p> <p>COLOURS: Standard - High Gloss Black Optional Colours - Brown, Forest Green & Matt Black Custom Colours Available Upon Request.</p>
---	---

The following note shall apply to all drawings and associated documents:
1. Copyright of this drawing and design is reserved by the Designer & European Wrought Iron Works Ltd. The drawing and all associated documents are an instrument of service by the Designer & European Wrought Iron Works Ltd. The drawing and the information contained therein may not be reproduced in whole or in part without prior written or verbal permission of the designer or European Wrought Iron Works Ltd.
2. Drawings are not to be scaled for construction. All existing site conditions and dimensions required to perform the work are to be verified and any discrepancies are to be reported to the designer & European Wrought Iron Works Ltd.
3. These drawings are not to be used for construction unless noted below as "Issued for Construction"
4. All work to be carried out in conformance with the Code and Bylaws of the authorities having jurisdiction.
5. The Designer of these plans and specifications gives no warranty or representation to any party about the constructability of the item represented by them.

CONFIDENTIAL: NOT TO BE DISCLOSED OR REPRODUCED



**ROYALTY COLLECTION
Palace**

TITLE: **Royalty Collection
Palace**

TOLERANCES INCHES UNLESS OTHERWISE NOTED
X.XXX" ±0.005"
X.XX" ±0.05"
X.X" ±0.25"
FRACTIONAL ±1/16"
ANGULAR ±1°

SCALE: NTS.

DATE DRAWN: June 2015
DRAWN BY: DCM

DO NOT MODIFY OR SCALE DRAWING

PROJECT TITLE:

DESIGN: P.D.

SHEET NO: 1

DRAWING & DESIGN REMAIN THE PROPERTY OF EUROPEAN WROUGHT IRON WORKS LTD.

FINISH: Custom

DRAWING NUMBER: RC-01

REV 1- A

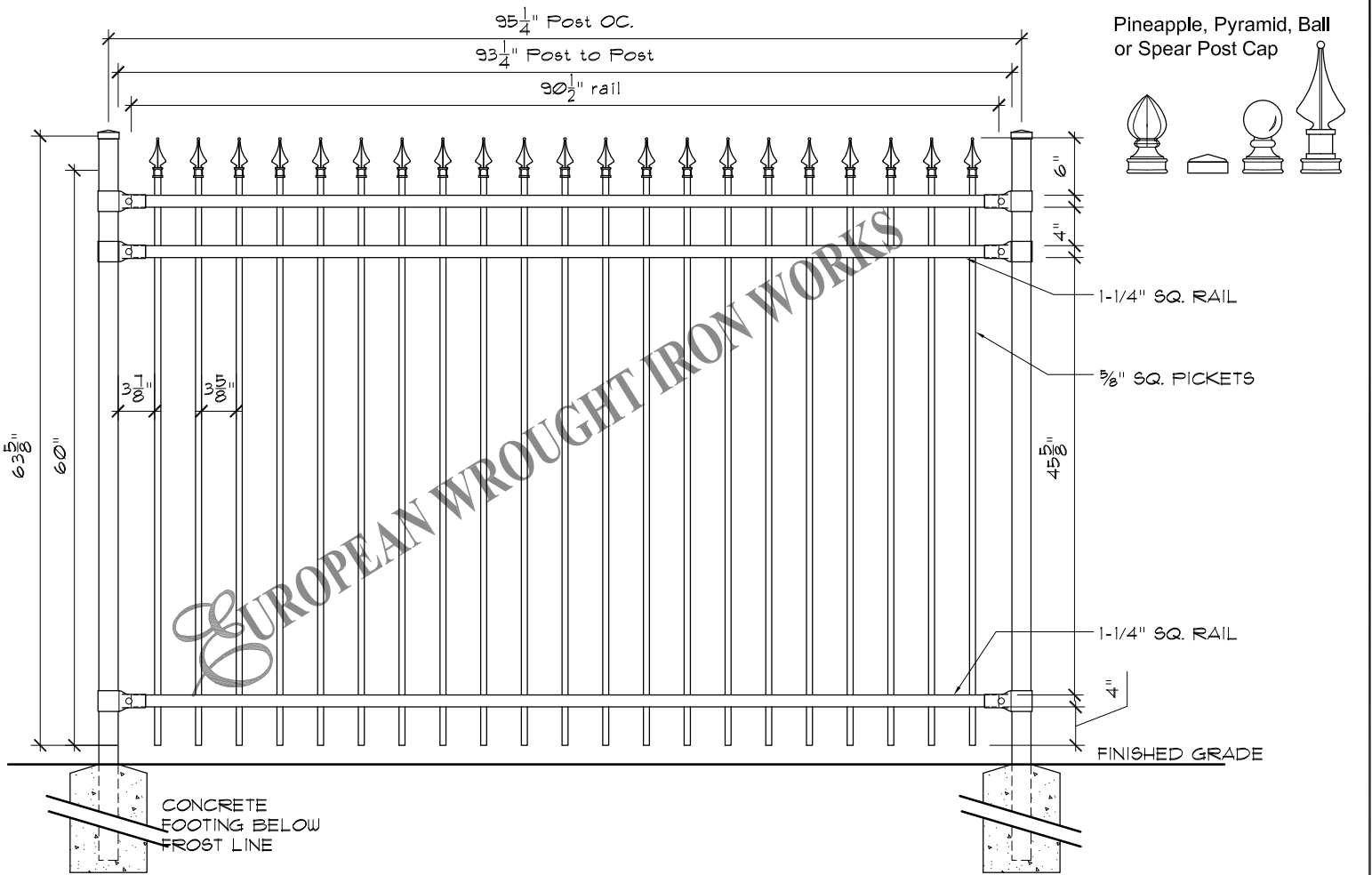

Pineapple, Pyramid, Ball or Spear Post Cap

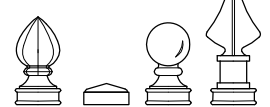

EUROPEAN WROUGHT IRON WORKS

1-1/4" SQ. RAIL
5/8" SQ. PICKETS
1-1/4" SQ. RAIL
4"
FINISHED GRADE

TYPICAL RAIL SECTION

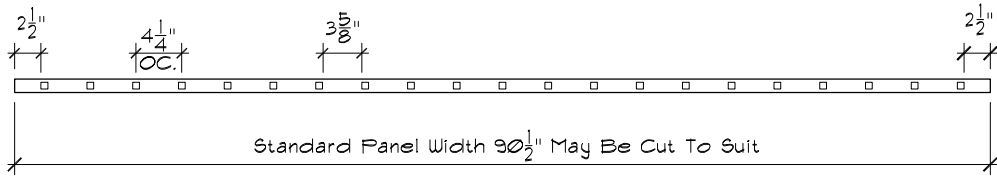
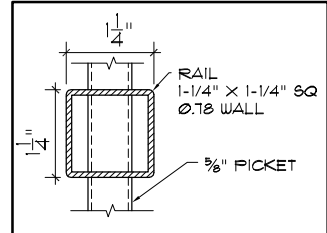

Specifications

<p>POST, RAILS & PICKETS: Cold Formed Steel Tubing Interior And Exterior Galvalume Coating Chromate Conversion Coating Electrostatically Applied Thermally Bonded Polyester Powder Coating Minimum Film Thickness 2.5 Mils</p> <p>POSTS: 2" x 2" (51mm x 51mm) 16 Gauge Standard Post Spacing 97-1/8" (2466mm) OC.</p> <p>POST CAP: Pyramid, Ball or Spear</p> <p>RAILS: 1-1/4" x 1-1/4" (32mm x 32mm) 14 Gauge</p> <p>PICKETS: 5/8" x 5/8" (15mm x 15mm) 16 Gauge</p>	<p>FITTINGS: 15 Gauge Stamp Forged Factory Finish. As Above</p> <p>WELDS: Stainless Steel</p> <p>STANDARD PANEL WIDTH: 91-1/2" (2324mm)</p> <p>AVAILABLE PANEL HEIGHTS: 48" (1219mm) (plus cap if applicable) 60" (1524mm) 72" (1828mm)</p> <p>NOTE: Tamper Proof Nut Available For Brackets</p> <p>COLOURS: Standard - High Gloss Black Optional Colours - Brown, Forest Green & Matt Black Custom Colours Available Upon Request.</p>
---	---

<p>The following note shall apply to all drawings and associated documents: 1. Copyright of this drawing and design is reserved by the Designer & European Wrought Iron Works Ltd. The drawing and all associated documents are an instrument of service by the Designer & European Wrought Iron Works Ltd. The drawing and the information contained therein may not be reproduced in whole or in part without prior written or verbal permission of the designer or European Wrought Iron Works Ltd. 2. Drawings are not to be scaled for construction. All existing site conditions and dimensions required to perform the work are to be verified and any discrepancies are to be reported to the designer & European Wrought Iron Works Ltd. 3. These drawings are not to be used for construction unless noted below as "Issued for Construction" 4. All work to be carried out in conformance with the Code and Bylaws of the authorities having jurisdiction. 5. The Designer of these plans and specifications gives no warranty or representation to any party about the constructability of the item represented by them.</p>	<p style="font-size: 8px;">CONFIDENTIAL: NOT TO BE DISCLOSED OR REPRODUCED</p> <p style="font-size: 8px;">WITHOUT THE WRITTEN PERMISSION OF EUROPEAN WROUGHT IRON WORKS LTD.</p>	<p>TOLERANCES INCHES UNLESS OTHERWISE NOTED X.XXX" ±0.005" X.XX" ±0.05" X.X" ±0.25" FRACTIONAL ±1/16" ANGULAR ±1°</p>	<p>DO NOT MODIFY OR SCALE DRAWING</p> <p>PROJECT TITLE:</p>	<p>DRAWING & DESIGN REMAIN THE PROPERTY OF EUROPEAN WROUGHT IRON WORKS LTD.</p>
<p>TITLE: Royalty Collection <i>Prince with Dbl. Top Rail</i></p>	<p>SCALE: NTS.</p> <p>DATE DRAWN: June 2015</p> <p>DRAWN BY: DCM</p>	<p>DESIGN: P.D.</p> <p>SHEET NO: 4a</p>	<p>FINISH: Custom</p> <p>DRAWING NUMBER: RC-04a</p>	<p>REV 1- A</p>

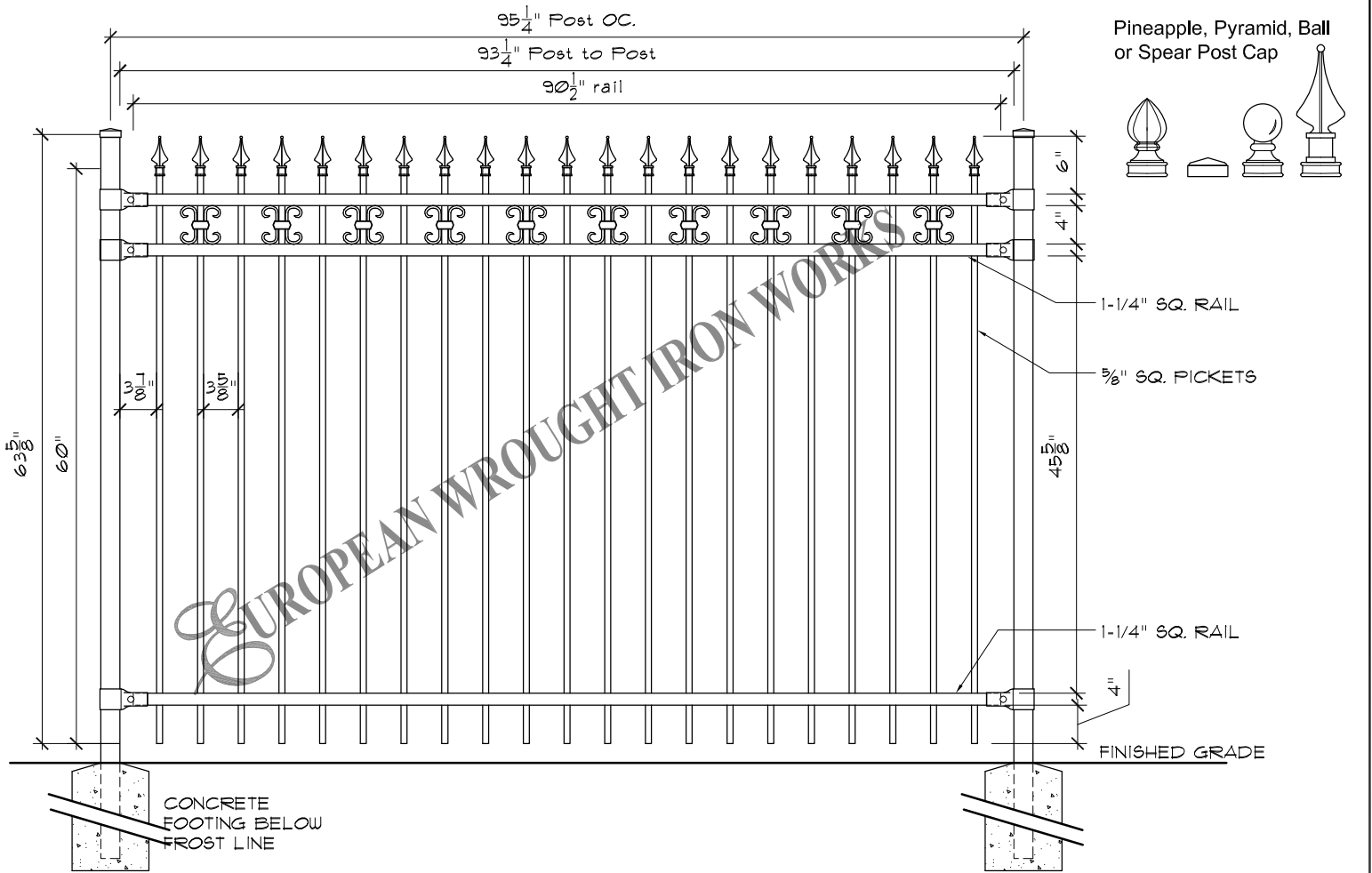

Pineapple, Pyramid, Ball or Spear Post Cap

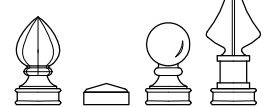

EUROPEAN WROUGHT IRON WORKS

1-1/4" SQ. RAIL

5/8" SQ. PICKETS

1-1/4" SQ. RAIL

FINISHED GRADE

CONCRETE FOOTING BELOW FROST LINE

TYPICAL RAIL SECTION

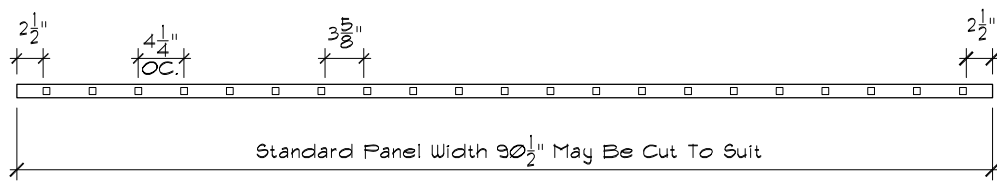
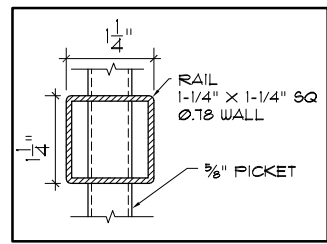

Specifications

<p>POST, RAILS & PICKETS: Cold Formed Steel Tubing Interior And Exterior Galvalume Coating Chromate Conversion Coating Electrostatically Applied Thermally Bonded Polyester Powder Coating Minimum Film Thickness 2.5 Mils</p> <p>POSTS: 2" x 2" (51mm x 51mm) 16 Gauge Standard Post Spacing 97-1/8" (2466mm) OC.</p> <p>POST CAP: Pyramid, Ball or Spear</p> <p>RAILS: 1-1/4" x 1-1/4" (32mm x 32mm) 14 Gauge</p> <p>PICKETS: 5/8" x 5/8" (15mm x 15mm) 16 Gauge</p>	<p>FITTINGS: 15 Gauge Stamp Forged Factory Finish. As Above</p> <p>WELDS: Stainless Steel</p> <p>STANDARD PANEL WIDTH: 91-1/2" (2324m)</p> <p>AVAILABLE PANEL HEIGHTS: 48" (1219mm) (plus cap if applicable) 60" (1524mm) 72" (1828mm)</p> <p>NOTE: Tamper Proof Nut Available For Brackets</p> <p>COLOURS: Standard - High Gloss Black Optional Colours - Brown, Forest Green & Matt Black Custom Colours Available Upon Request.</p>
---	--

The following note shall apply to all drawings and associated documents:
 1. Copyright of this drawing and design is reserved by the Designer & European Wrought Iron Works Ltd. The drawing and all associated documents are an instrument of service by the Designer & European Wrought Iron Works Ltd. The drawing and the information contained therein may not be reproduced in whole or in part without prior written or verbal permission of the designer or European Wrought Iron Works Ltd.
 2. Drawings are not to be scaled for construction. All existing site conditions and dimensions required to perform the work are to be verified and any discrepancies are to be reported to the designer & European Wrought Iron Works Ltd.
 3. These drawings are not to be used for construction unless noted below as "Issued for Construction"
 4. All work to be carried out in conformance with the Code and Bylaws of the authorities having jurisdiction.
 5. The Designer of these plans and specifications gives no warranty or representation to any party about the constructability of the item represented by them.

CONFIDENTIAL: NOT TO BE DISCLOSED OR REPRODUCED



ROYALTY COLLECTION
Prince Custom

TITLE: **Royalty Collection**
Prince Custom

TOLERANCES INCHES UNLESS OTHERWISE NOTED
 X.XXX" ±0.005"
 X.XX" ±0.05"
 X.X" ±0.25"
 FRACTIONAL ±1/16"
 ANGULAR ±1°

SCALE: NTS.

DATE DRAWN: June 2015
 DRAWN BY: DCM

DO NOT MODIFY OR SCALE DRAWING

PROJECT TITLE:

DESIGN: P.D.

SHEET NO: 4b

DRAWING & DESIGN REMAIN THE PROPERTY OF EUROPEAN WROUGHT IRON WORKS LTD.

FINISH: Custom

DRAWING NUMBER: RC-04b

REV 1- A

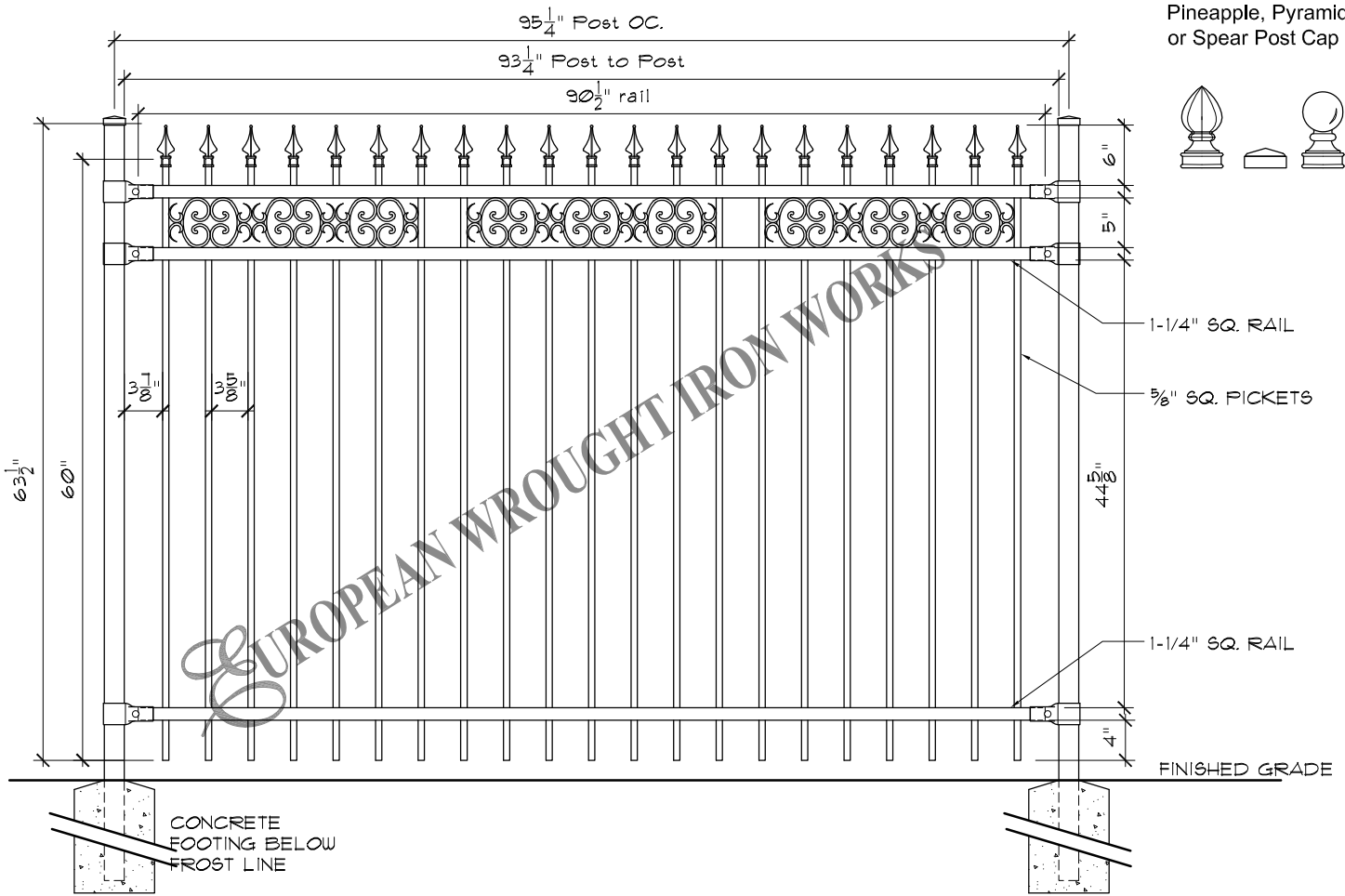

Pineapple, Pyramid, Ball or Spear Post Cap

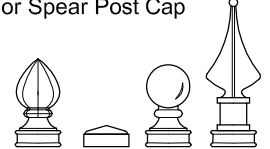

1-1/4" SQ. RAIL

5/8" SQ. PICKETS

1-1/4" SQ. RAIL

FINISHED GRADE

CONCRETE FOOTING BELOW FROST LINE

TYPICAL RAIL SECTION

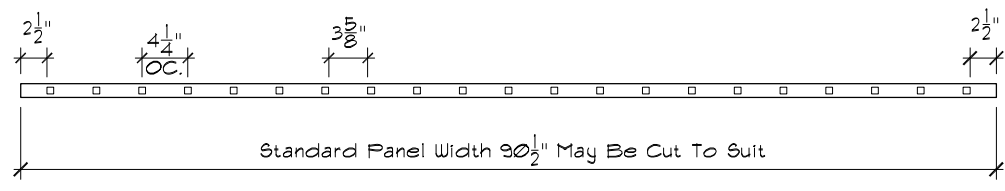
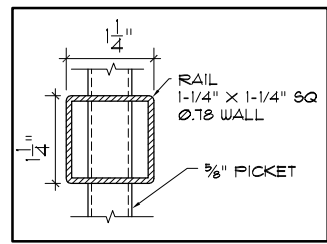

Specifications

<p>POST, RAILS & PICKETS: Cold Formed Steel Tubing Interior And Exterior Galvalume Coating Chromate Conversion Coating Electrostatically Applied Thermally Bonded Polyester Powder Coating Minimum Film Thickness 2.5 Mils</p> <p>POSTS: 2" x 2" (51mm x 51mm) 16 Gauge Standard Post Spacing 97-1/8" (2466mm) OC.</p> <p>POST CAP: Pyramid, Ball or Spear</p> <p>RAILS: 1-1/4" x 1-1/4" (32mm x 32mm) 14 Gauge</p> <p>PICKETS: 5/8" x 5/8" (15mm x 15mm) 16 Gauge</p>	<p>FITTINGS: 15 Gauge Stamp Forged Factory Finish. As Above</p> <p>WELDS: Stainless Steel</p> <p>STANDARD PANEL WIDTH: 91-1/2" (2324mm)</p> <p>AVAILABLE PANEL HEIGHTS: 48" (1219mm) (plus cap if applicable) 60" (1524mm) 72" (1828mm)</p> <p>NOTE: Tamper Proof Nut Available For Brackets</p> <p>COLOURS: Standard - High Gloss Black Optional Colours - Brown, Forest Green & Matt Black Custom Colours Available Upon Request.</p>
---	---

<p>The following note shall apply to all drawings and associated documents:</p> <p>1. Copyright of this drawing and design is reserved by the Designer & European Wrought Iron Works Ltd. The drawing and all associated documents are an instrument of service by the Designer & European Wrought Iron Works Ltd. The drawing and the information contained therein may not be reproduced in whole or in part without prior written or verbal permission of the designer or European Wrought Iron Works Ltd.</p> <p>2. Drawings are not to be scaled for construction. All existing site conditions and dimensions required to perform the work are to be verified and any discrepancies are to be reported to the designer & European Wrought Iron Works Ltd.</p> <p>3. These drawings are not to be used for construction unless noted below as "Issued for Construction"</p> <p>4. All work to be carried out in conformance with the Code and Bylaws of the authorities having jurisdiction.</p> <p>5. The Designer of these plans and specifications gives no warranty or representation to any party about the constructability of the item represented by them.</p>	<p style="font-size: 8px;">CONFIDENTIAL: NOT TO BE DISCLOSED OR REPRODUCED</p> <p style="font-size: 8px;">WITHOUT THE WRITTEN PERMISSION OF EUROPEAN WROUGHT IRON WORKS LTD.</p>	<p>TOLERANCES INCHES UNLESS OTHERWISE NOTED X.XXX" ±0.005" X.XX" ±0.05" X.X" ±0.25" FRACTIONAL ±1/16" ANGULAR ±1°</p>	<p>DO NOT MODIFY OR SCALE DRAWING</p> <p>PROJECT TITLE:</p>	<p>DRAWING & DESIGN REMAIN THE PROPERTY OF EUROPEAN WROUGHT IRON WORKS LTD.</p>		
<p>TITLE: Royalty Collection <i>Prince Custom with Casting</i></p>	<p>SCALE: NTS.</p> <p>DATE DRAWN: June 2015</p> <p>DRAWN BY: DCM</p>	<p>DESIGN: P.D.</p> <p>SHEET NO: 4c</p>	<p>FINISH: Custom</p> <p>DRAWING NUMBER: RC-04c</p>	<p>REV 1-</p>	<p>A</p>	

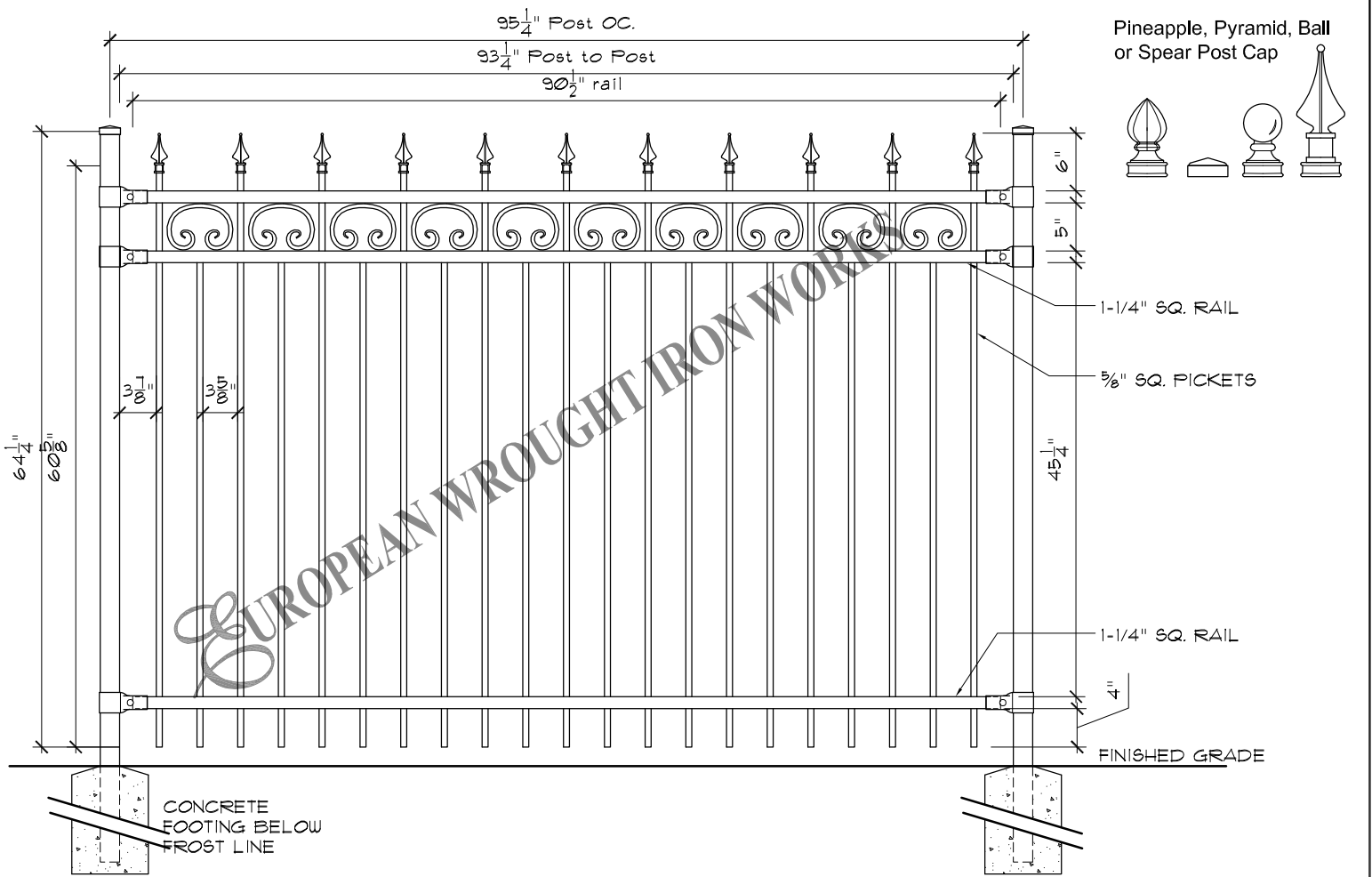

Pineapple, Pyramid, Ball or Spear Post Cap

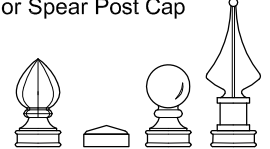

TYPICAL RAIL SECTION

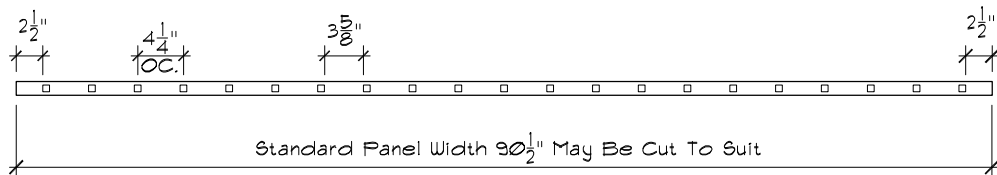
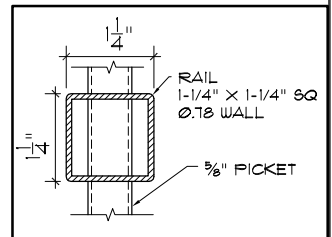

Specifications

POST, RAILS & PICKETS: Cold Formed Steel Tubing
Interior And Exterior Galvalume Coating
Chromate Conversion Coating
Electrostatically Applied
Thermally Bonded Polyester Powder Coating
Minimum Film Thickness 2.5 Mils

POSTS: 2" x 2" (51mm x 51mm) 16 Gauge
Standard Post Spacing 97-1/8" (2466mm) OC.

POST CAP: Pyramid, Ball or Spear

RAILS: 1-1/4" x 1-1/4" (32mm x 32mm) 14 Gauge

PICKETS: 5/8" x 5/8" (15mm x 15mm) 16 Gauge

FITTINGS: 15 Gauge Stamp Forged Factory Finish. As Above

WELDS: Stainless Steel

STANDARD PANEL WIDTH: 91-1/2" (2324mm)

AVAILABLE PANEL HEIGHTS: 48" (1219mm)
(plus cap if applicable) 60" (1524mm)
72" (1828mm)

NOTE: Tamper Proof Nut Available For Brackets

COLOURS: Standard - High Gloss Black
Optional Colours - Brown, Forest Green & Matt Black
Custom Colours Available Upon Request.

The following note shall apply to all drawings and associated documents:
1. Copyright of this drawing and design is reserved by the Designer & European Wrought Iron Works Ltd. The drawing and all associated documents are an instrument of service by the Designer & European Wrought Iron Works Ltd. The drawing and the information contained therein may not be reproduced in whole or in part without prior written or verbal permission of the designer or European Wrought Iron Works Ltd.
2. Drawings are not to be scaled for construction. All existing site conditions and dimensions required to perform the work are to be verified and any discrepancies are to be reported to the designer & European Wrought Iron Works Ltd.
3. These drawings are not to be used for construction unless noted below as "Issued for Construction"
4. All work to be carried out in conformance with the Code and Bylaws of the authorities having jurisdiction.
5. The Designer of these plans and specifications gives no warranty or representation to any party about the constructability of the item represented by them.

CONFIDENTIAL: NOT TO BE DISCLOSED OR REPRODUCED

WITHOUT THE WRITTEN PERMISSION OF EUROPEAN WROUGHT IRON WORKS LTD.

TITLE: Royalty Collection
Prince Custom With Scroll

TOLERANCES INCHES UNLESS OTHERWISE NOTED
X.XXX" ±0.005"
X.XX" ±0.05"
X.X" ±0.25"
FRACTIONAL ±1/16"
ANGULAR ±1°

SCALE: NTS.

DATE DRAWN: June 2015

DRAWN BY: DCM

DO NOT MODIFY OR SCALE DRAWING

PROJECT TITLE:

DESIGN: P.D.

SHEET NO: 4d

DRAWING & DESIGN REMAIN THE PROPERTY OF EUROPEAN WROUGHT IRON WORKS LTD.

FINISH: Custom

DRAWING NUMBER: RC-04d

REV: 1- A

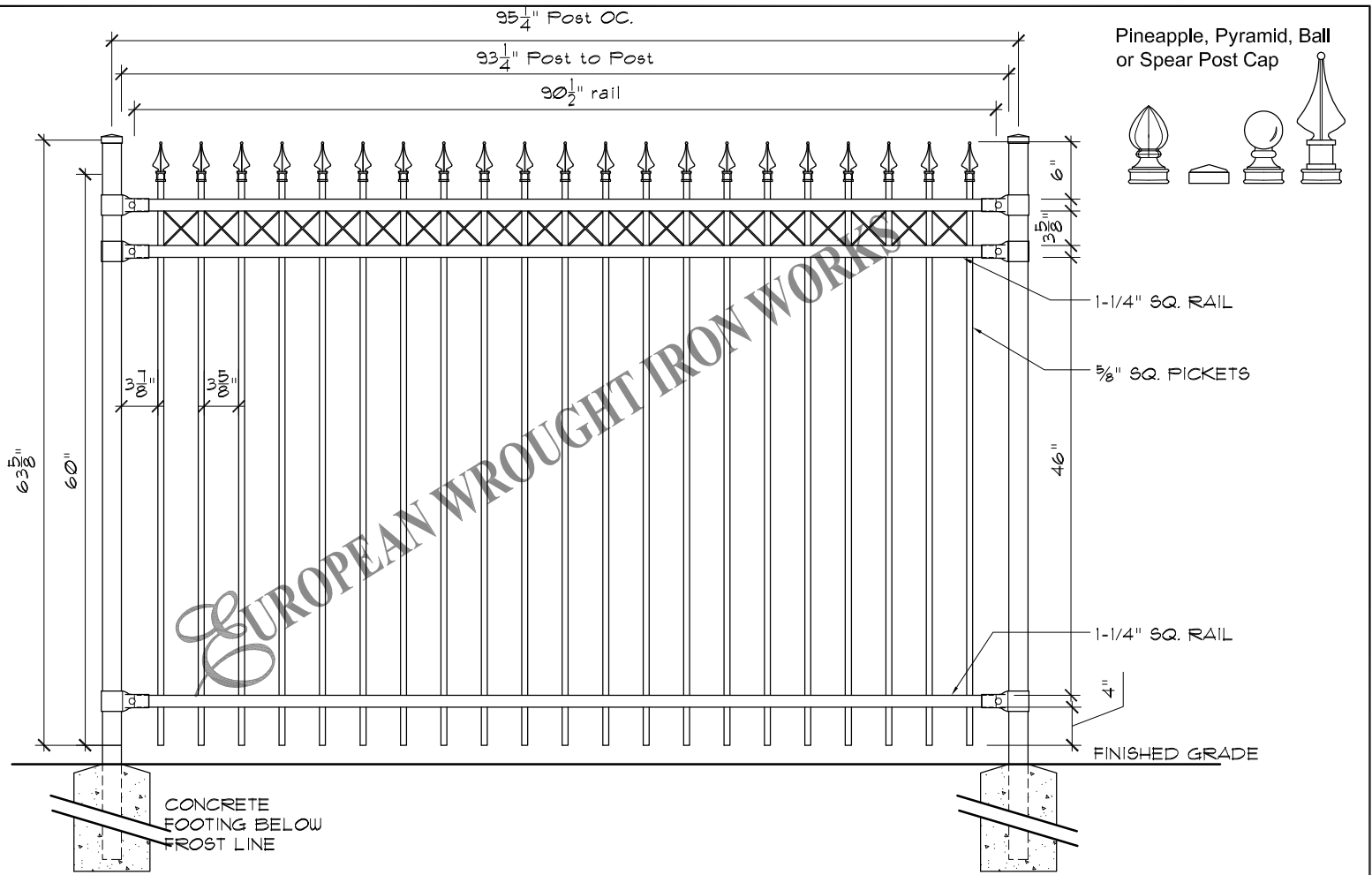

Pineapple, Pyramid, Ball or Spear Post Cap

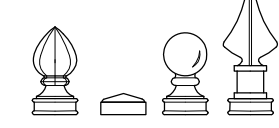

1-1/4" SQ RAIL
5/8" SQ PICKETS
1-1/4" SQ RAIL
4"
FINISHED GRADE

EUROPEAN WROUGHT IRON WORKS

TYPICAL RAIL SECTION

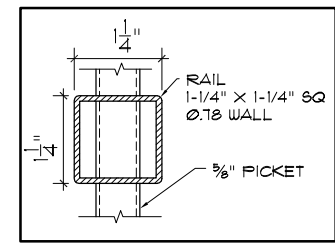

Specifications

<p>POST, RAILS & PICKETS: Cold Formed Steel Tubing Interior And Exterior Galvalume Coating Chromate Conversion Coating Electrostatically Applied Thermally Bonded Polyester Powder Coating Minimum Film Thickness 2.5 Mils</p> <p>POSTS: 2" x 2" (51mm x 51mm) 16 Gauge Standard Post Spacing 97-1/8" (2466mm) OC.</p> <p>POST CAP: Pyramid, Ball or Spear</p> <p>RAILS: 1-1/4" x 1-1/4" (32mm x 32mm) 14 Gauge</p> <p>PICKETS: 5/8" x 5/8" (15mm x 15mm) 16 Gauge</p>	<p>FITTINGS: 15 Gauge Stamp Forged Factory Finish. As Above</p> <p>WELDS: Stainless Steel</p> <p>STANDARD PANEL WIDTH: 91-1/2" (2324mm)</p> <p>AVAILABLE PANEL HEIGHTS: 48" (1219mm) (plus cap if applicable) 60" (1524mm) 72" (1828mm)</p> <p>NOTE: Tamper Proof Nut Available For Brackets</p> <p>COLOURS: Standard - High Gloss Black Optional Colours - Brown, Forest Green & Matt Black Custom Colours Available Upon Request.</p>
---	---

<p>The following note shall apply to all drawings and associated documents:</p> <p>1. Copyright of this drawing and design is reserved by the Designer & European Wrought Iron Works Ltd. The drawing and all associated documents are an instrument of service by the Designer & European Wrought Iron Works Ltd. The drawing and the information contained therein may not be reproduced in whole or in part without prior written or verbal permission of the designer or European Wrought Iron Works Ltd.</p> <p>2. Drawings are not to be scaled for construction. All existing site conditions and dimensions required to perform the work are to be verified and any discrepancies are to be reported to the designer & European Wrought Iron Works Ltd.</p> <p>3. These drawings are not to be used for construction unless noted below as "Issued for Construction"</p> <p>4. All work to be carried out in conformance with the Code and Bylaws of the authorities having jurisdiction.</p> <p>5. The Designer of these plans and specifications gives no warranty or representation to any party about the constructability of the item represented by them.</p>	<p>CONFIDENTIAL: NOT TO BE DISCLOSED OR REPRODUCED</p> <p>WITHOUT THE WRITTEN PERMISSION OF EUROPEAN WROUGHT IRON WORKS LTD.</p>	<p>TOLERANCES INCHES UNLESS OTHERWISE NOTED X.XXX" ±0.005" X.XX" ±0.05" X.X" ±0.25" FRACTIONAL ±1/16" ANGULAR ±1°</p>	<p>DO NOT MODIFY OR SCALE DRAWING</p> <p>PROJECT TITLE:</p>	<p>DRAWING & DESIGN REMAIN THE PROPERTY OF EUROPEAN WROUGHT IRON WORKS LTD.</p>		
<p>TITLE: Royalty Collection <i>Prince Custom with Cross</i></p>	<p>SCALE: NTS.</p> <p>DATE DRAWN: June 2015</p> <p>DRAWN BY: DCM</p>	<p>DESIGN: P.D.</p> <p>SHEET NO: 4f</p>	<p>FINISH: Custom</p> <p>DRAWING NUMBER: RC-04f</p>	<p>REV 1-</p> <p>A</p>		

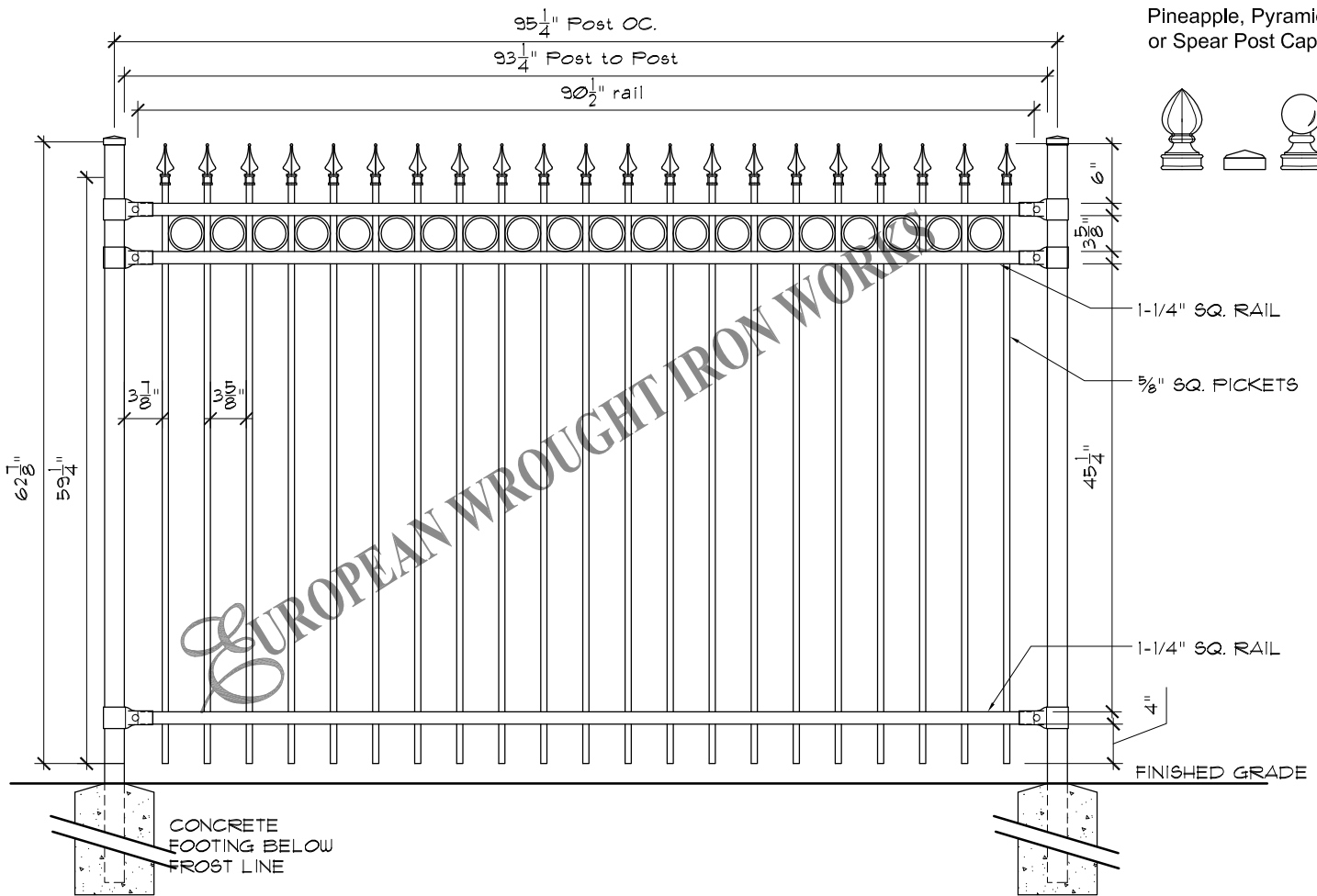

Pineapple, Pyramid, Ball or Spear Post Cap

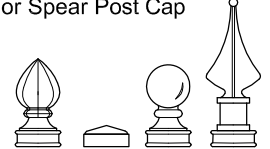

1-1/4" SQ. RAIL
5/8" SQ. PICKETS

1-1/4" SQ. RAIL

FINISHED GRADE

CONCRETE FOOTING BELOW FROST LINE

TYPICAL RAIL SECTION

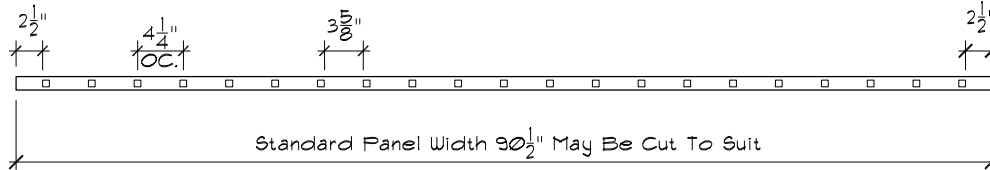
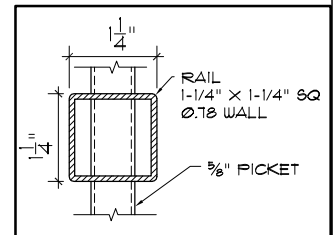

Specifications

POST, RAILS & PICKETS: Cold Formed Steel Tubing
Interior And Exterior Galvalume Coating
Chromate Conversion Coating
Electrostatically Applied
Thermally Bonded Polyester Powder Coating
Minimum Film Thickness 2.5 Mils

POSTS: 2" x 2" (51mm x 51mm) 16 Gauge
Standard Post Spacing 97-1/8" (2466mm) OC.

POST CAP: Pyramid, Ball or Spear

RAILS: 1-1/4" x 1-1/4" (32mm x 32mm) 14 Gauge

PICKETS: 5/8" x 5/8" (15mm x 15mm) 16 Gauge

FITTINGS: 15 Gauge Stamp Forged Factory Finish. As Above

WELDS: Stainless Steel

STANDARD PANEL WIDTH: 91-1/2" (2324mm)

AVAILABLE PANEL HEIGHTS: 48" (1219mm)
(plus cap if applicable) 60" (1524mm)
72" (1828mm)

NOTE: Tamper Proof Nut Available For Brackets

COLOURS: Standard - High Gloss Black
Optional Colours - Brown, Forest Green & Matt Black

Custom Colours Available Upon Request.

The following note shall apply to all drawings and associated documents:

- Copyright of this drawing and design is reserved by the Designer & European Wrought Iron Works Ltd. The drawing and all associated documents are an instrument of service by the Designer & European Wrought Iron Works Ltd. The drawing and the information contained therein may not be reproduced in whole or in part without prior written or verbal permission of the designer or European Wrought Iron Works Ltd.
- Drawings are not to be scaled for construction. All existing site conditions and dimensions required to perform the work are to be verified and any discrepancies are to be reported to the designer & European Wrought Iron Works Ltd.
- These drawings are not to be used for construction unless noted below as "Issued for Construction"
- All work to be carried out in conformance with the Code and Bylaws of the authorities having jurisdiction.
- The Designer of these plans and specifications gives no warranty or representation to any party about the constructability of the item represented by them.

CONFIDENTIAL: NOT TO BE DISCLOSED OR REPRODUCED



TITLE: **Royalty Collection**
Prince Custom with Circle

TOLERANCES INCHES UNLESS OTHERWISE NOTED
X.XXX" ±0.005"
X.XX" ±0.05"
X.X" ±0.25"
FRACTIONAL ±1/16"
ANGULAR ±1°

SCALE: NTS.
DATE DRAWN: June 2015
DRAWN BY: DCM

DO NOT MODIFY OR SCALE DRAWING

PROJECT TITLE:

DESIGN: P.D.
SHEET NO: 4g

DRAWING & DESIGN REMAIN THE PROPERTY OF EUROPEAN WROUGHT IRON WORKS LTD.

FINISH: Custom
DRAWING NUMBER: RC-04g

REV 1- A

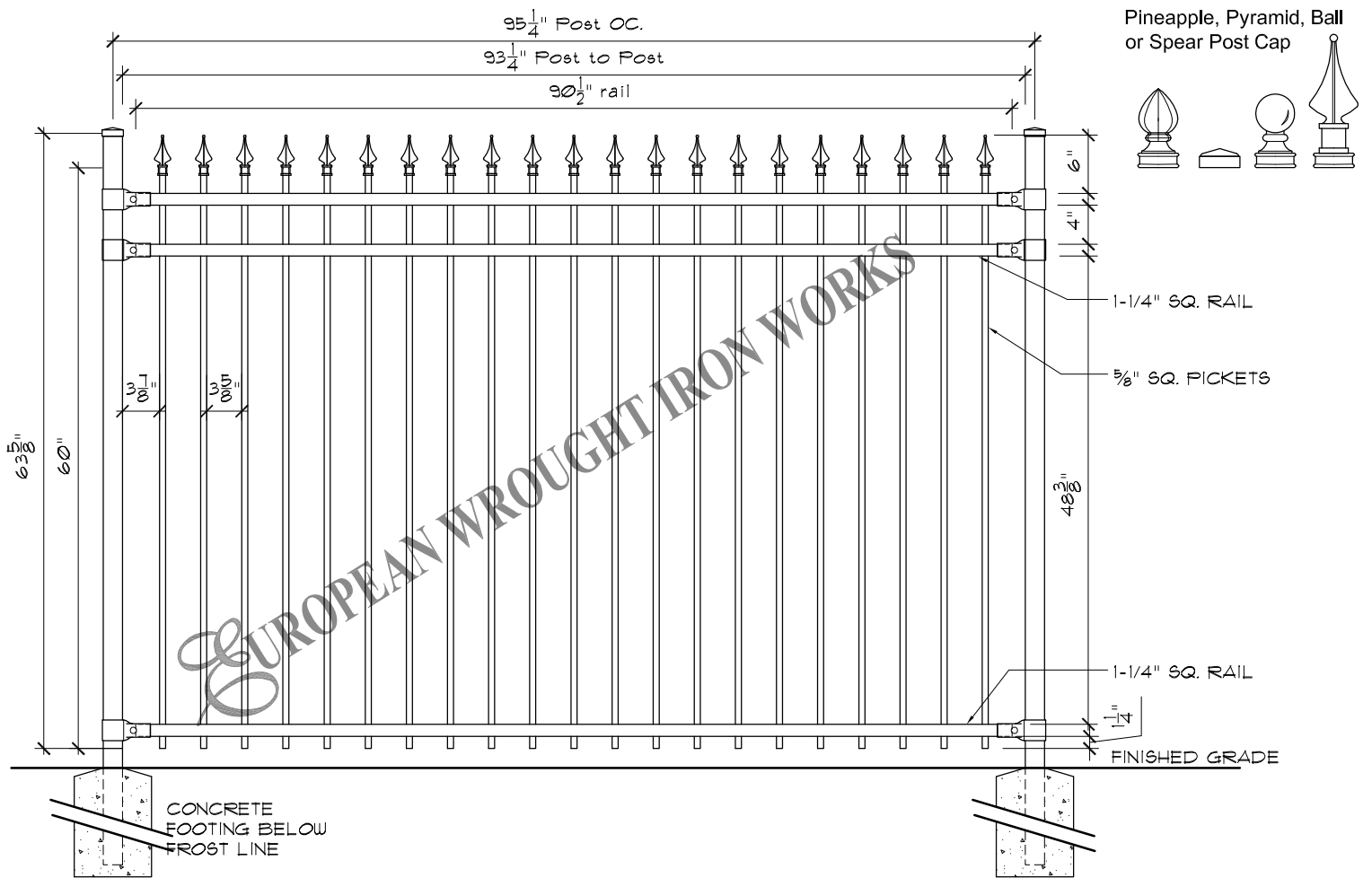

Pineapple, Pyramid, Ball or Spear Post Cap

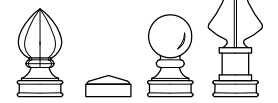

EUROPEAN WROUGHT IRON WORKS

1-1/4" SQ. RAIL
5/8" SQ. PICKETS

1-1/4" SQ. RAIL

FINISHED GRADE

CONCRETE FOOTING BELOW FROST LINE

TYPICAL RAIL SECTION

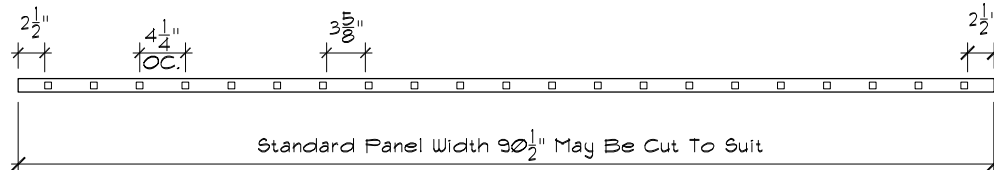
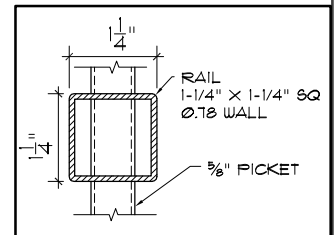

Specifications

POST, RAILS & PICKETS: Cold Formed Steel Tubing
Interior And Exterior Galvalume Coating
Chromate Conversion Coating
Electrostatically Applied
Thermally Bonded Polyester Powder Coating
Minimum Film Thickness 2.5 Mils

POSTS: 2" x 2" (51mm x 51mm) 16 Gauge
Standard Post Spacing 97-1/8" (2466mm) OC.

POST CAP: Pyramid, Ball or Spear

RAILS: 1-1/4" x 1-1/4" (32mm x 32mm) 14 Gauge

PICKETS: 5/8" x 5/8" (15mm x 15mm) 16 Gauge

FITTINGS: 15 Gauge Stamp Forged Factory Finish. As Above

WELDS: Stainless Steel

STANDARD PANEL WIDTH: 91-1/2" (2324m)

AVAILABLE PANEL HEIGHTS: 48" (1219mm)
(plus cap if applicable) 60" (1524mm)
72" (1828mm)

NOTE: Tamper Proof Nut Available For Brackets

COLOURS: Standard - High Gloss Black
Optional Colours - Brown, Forest Green & Matt Black
Custom Colours Available Upon Request.

The following note shall apply to all drawings and associated documents:
1. Copyright of this drawing and design is reserved by the Designer & European Wrought Iron Works Ltd. The drawing and all associated documents are an instrument of service by the Designer & European Wrought Iron Works Ltd. The drawing and the information contained therein may not be reproduced in whole or in part without prior written or verbal permission of the designer or European Wrought Iron Works Ltd.
2. Drawings are not to be scaled for construction. All existing site conditions and dimensions required to perform the work are to be verified and any discrepancies are to be reported to the designer & European Wrought Iron Works Ltd.
3. These drawings are not to be used for construction unless noted below as "Issued for Construction"
4. All work to be carried out in conformance with the Code and Bylaws of the authorities having jurisdiction.
5. The Designer of these plans and specifications gives no warranty or representation to any party about the constructability of the item represented by them.

CONFIDENTIAL: NOT TO BE DISCLOSED OR REPRODUCED

EUROPEAN WROUGHT IRON WORKS
WITHOUT THE WRITTEN PERMISSION OF EUROPEAN WROUGHT IRON WORKS LTD.

TITLE:
Royalty Collection
Prince with Dbl. Top Rail PS.

TOLERANCES UNLESS OTHERWISE NOTED
INCHES
X.XXX" ±0.005"
X.XX" ±0.05"
X.X" ±0.25"
FRACTIONAL ±1/16"
ANGULAR ±1°

SCALE: NTS.

DATE DRAWN: June 2015

DRAWN BY: DCM

DO NOT MODIFY OR SCALE DRAWING

PROJECT TITLE:

DESIGN: P.D.

SHEET NO: 4h

DRAWING & DESIGN REMAIN THE PROPERTY OF EUROPEAN WROUGHT IRON WORKS LTD.

FINISH: Custom

DRAWING NUMBER: RC-04h

REV: 1- A

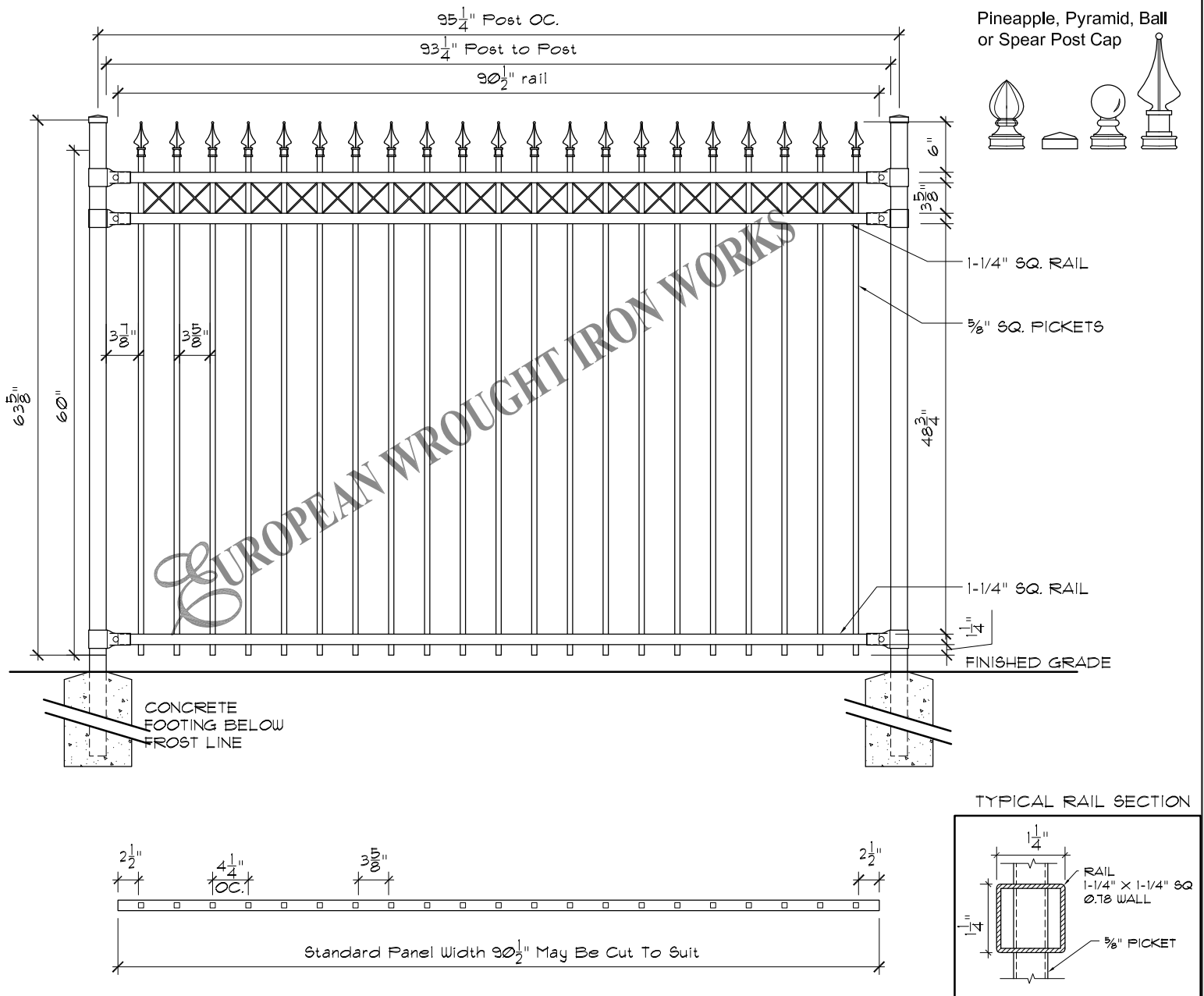

Specifications

POST, RAILS & PICKETS: Cold Formed Steel Tubing
Interior And Exterior Galvalume Coating
Chromate Conversion Coating
Electrostatically Applied
Thermally Bonded Polyester Powder Coating
Minimum Film Thickness 2.5 Mils

POSTS: 2" x 2" (51mm x 51mm) 16 Gauge
Standard Post Spacing 97-1/8" (2466mm) OC.

POST CAP: Pyramid, Ball or Spear

RAILS: 1-1/4" x 1-1/4" (32mm x 32mm) 14 Gauge

PICKETS: 5/8" x 5/8" (15mm x 15mm) 16 Gauge

FITTINGS: 15 Gauge Stamp Forged Factory Finish. As Above

WELDS: Stainless Steel

STANDARD PANEL WIDTH: 91-1/2" (2324m)

AVAILABLE PANEL HEIGHTS: 48" (1219mm)
(plus cap if applicable) 60" (1524mm)
72" (1828mm)

NOTE: Tamper Proof Nut Available For Brackets

COLOURS: Standard - High Gloss Black
Optional Colours - Brown, Forest Green & Matt Black
Custom Colours Available Upon Request.

The following note shall apply to all drawings and associated documents:

- Copyright of this drawing and design is reserved by the Designer & European Wrought Iron Works Ltd. The drawing and all associated documents are an instrument of service by the Designer & European Wrought Iron Works Ltd. The drawing and the information contained therein may not be reproduced in whole or in part without prior written or verbal permission of the designer or European Wrought Iron Works Ltd.
- Drawings are not to be scaled for construction. All existing site conditions and dimensions required to perform the work are to be verified and any discrepancies are to be reported to the designer & European Wrought Iron Works Ltd.
- These drawings are not to be used for construction unless noted below as "Issued for Construction"
- All work to be carried out in conformance with the Code and Bylaws of the authorities having jurisdiction.
- The Designer of these plans and specifications gives no warranty or representation to any party about the constructability of the item represented by them.

CONFIDENTIAL: NOT TO BE DISCLOSED OR REPRODUCED

EUROPEAN
WROUGHT IRON WORKS
WITHOUT THE WRITTEN PERMISSION OF EUROPEAN WROUGHT IRON WORKS LTD.

TITLE: **Royalty Collection**
Prince Custom with Cross PS.

TOLERANCES
INCHES
UNLESS OTHERWISE NOTED
X.XXX" ±0.005"
X.XX" ±0.05"
X.X" ±0.25"
FRACTIONAL ±1/16"
ANGULAR ±1°

SCALE: NTS.
DATE DRAWN: June 2015
DRAWN BY: DCM

DO NOT
MODIFY OR
SCALE DRAWING

PROJECT TITLE:
DESIGN: P.D.
SHEET NO: 4j

DRAWING & DESIGN REMAIN THE PROPERTY OF EUROPEAN WROUGHT IRON WORKS LTD.

FINISH: Custom
DRAWING NUMBER: RC-04j
REV 1- A

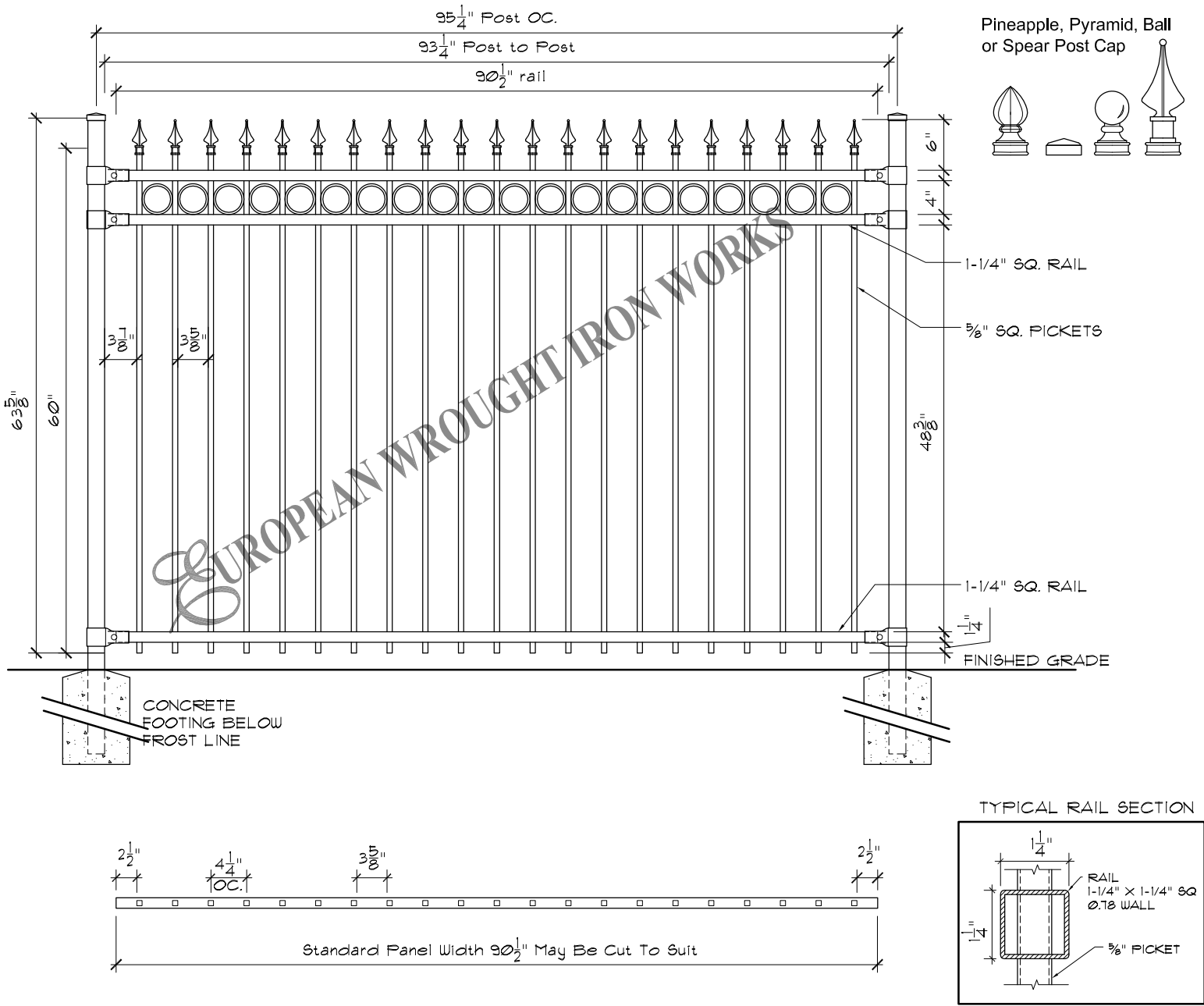

Specifications

POST, RAILS & PICKETS:	Cold Formed Steel Tubing Interior And Exterior Galvalume Coating Chromate Conversion Coating Electrostatically Applied Thermally Bonded Polyester Powder Coating Minimum Film Thickness 2.5 Mils	FITTINGS:	15 Gauge Stamp Forged Factory Finish. As Above
POSTS:	2" x 2" (51mm x 51mm) 16 Gauge Standard Post Spacing 97-1/8" (2466mm) OC.	WELDS:	Stainless Steel
POST CAP:	Pyramid, Ball or Spear	STANDARD PANEL WIDTH:	91-1/2" (2324mm)
RAILS:	1-1/4" x 1-1/4" (32mm x 32mm) 14 Gauge	AVAILABLE PANEL HEIGHTS:	48" (1219mm) (plus cap if applicable) 60" (1524mm) 72" (1828mm)
PICKETS:	5/8" x 5/8" (15mm x 15mm) 16 Gauge	NOTE:	Tamper Proof Nut Available For Brackets
		COLOURS:	Standard - High Gloss Black Optional Colours - Brown, Forest Green & Matt Black Custom Colours Available Upon Request.

The following note shall apply to all drawings and associated documents:

- Copyright of this drawing and design is reserved by the Designer & European Wrought Iron Works Ltd. The drawing and all associated documents are an instrument of service by the Designer & European Wrought Iron Works Ltd. The drawing and the information contained therein may not be reproduced in whole or in part without prior written or verbal permission of the designer or European Wrought Iron Works Ltd.
- Drawings are not to be scaled for construction. All existing site conditions and dimensions required to perform the work are to be verified and any discrepancies are to be reported to the designer & European Wrought Iron Works Ltd.
- These drawings are not to be used for construction unless noted below as "Issued for Construction"
- All work to be carried out in conformance with the Code and Bylaws of the authorities having jurisdiction.
- The Designer of these plans and specifications gives no warranty or representation to any party about the constructability of the item represented by them.

CONFIDENTIAL: NOT TO BE DISCLOSED OR REPRODUCED



TITLE:
Royalty Collection
Prince Custom with Alt. Circle

TOLERANCES
INCHES
UNLESS OTHERWISE NOTED
X.XXX" ±0.005"
X.XX" ±0.05"
X.X" ±0.25"
FRACTIONAL ±1/16"
ANGULAR ±1°

SCALE: NTS.
DATE DRAWN: June 2020
DRAWN BY: DCM

DO NOT
MODIFY OR
SCALE DRAWING

PROJECT TITLE:

DESIGN: P.D.
SHEET NO: 4k

DRAWING & DESIGN REMAIN THE PROPERTY OF EUROPEAN WROUGHT IRON WORKS LTD.

FINISH: Custom
DRAWING NUMBER: RC-04k

REV 1- A

Pineapple, Pyramid, Ball or Spear Post Cap

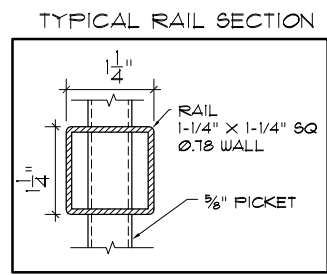
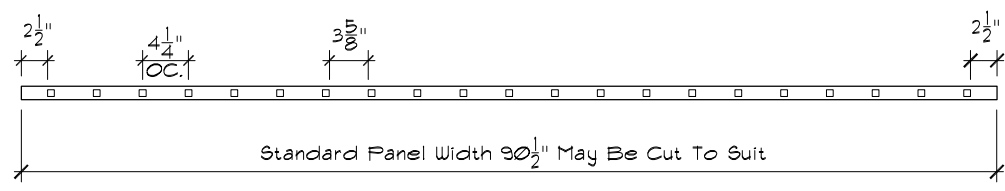
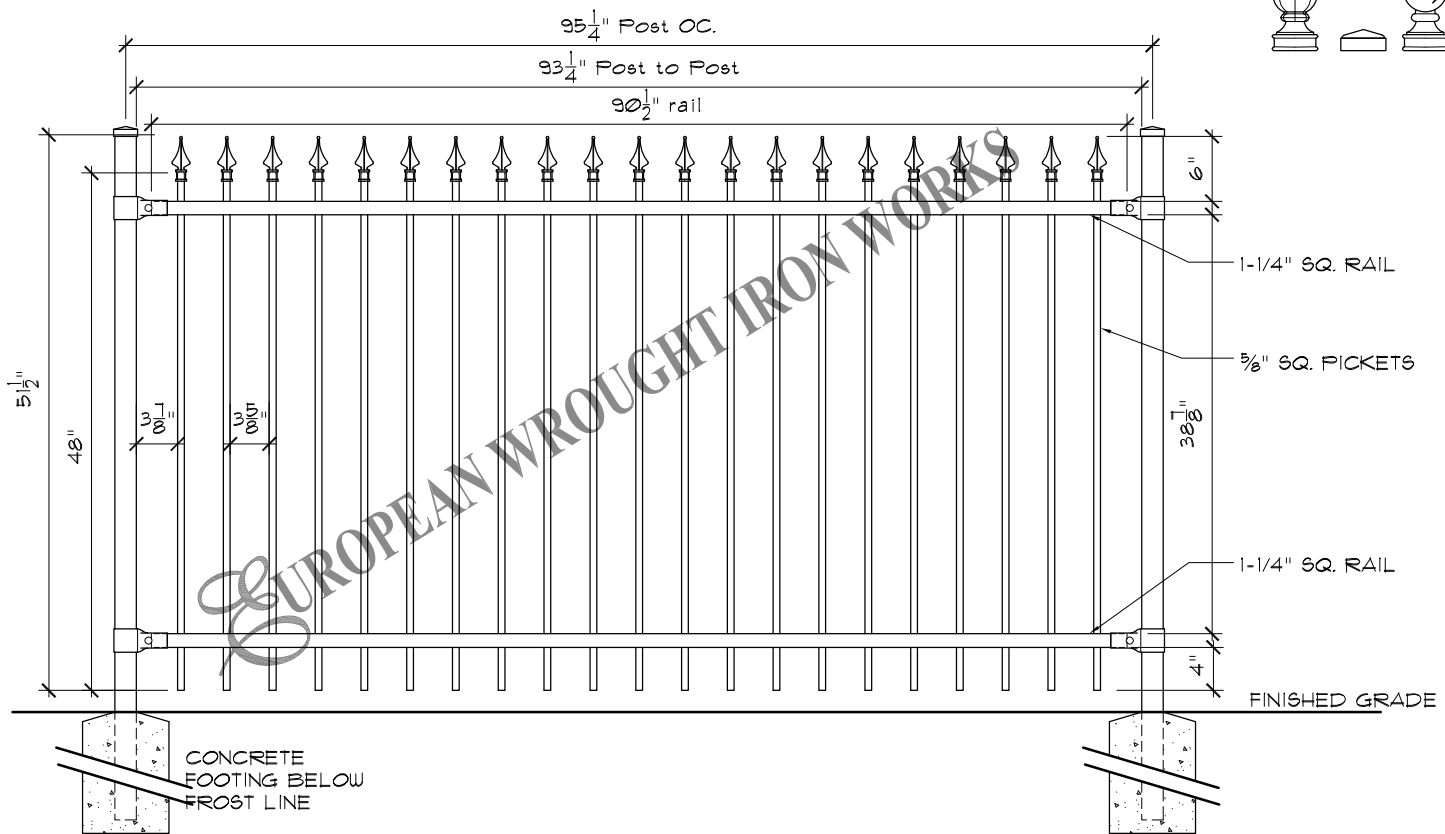
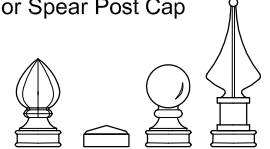

Specifications

<p>POST, RAILS & PICKETS: Cold Formed Steel Tubing Interior And Exterior Galvalume Coating Chromate Conversion Coating Electrostatically Applied Thermally Bonded Polyester Powder Coating Minimum Film Thickness 2.5 Mils</p> <p>POSTS: 2" x 2" (51mm x 51mm) 16 Gauge Standard Post Spacing 97-1/8" (2466mm) OC.</p> <p>POST CAP: Pyramid, Ball or Spear</p> <p>RAILS: 1-1/4" x 1-1/4" (32mm x 32mm) 14 Gauge</p> <p>PICKETS: 5/8" x 5/8" (15mm x 15mm) 16 Gauge</p>	<p>FITTINGS: 15 Gauge Stamp Forged Factory Finish. As Above</p> <p>WELDS: Stainless Steel</p> <p>STANDARD PANEL WIDTH: 91-1/2" (2324mm)</p> <p>AVAILABLE PANEL HEIGHTS: 48" (1219mm) (plus cap if applicable) 60" (1524mm) 72" (1828mm)</p> <p>NOTE: Tamper Proof Nut Available For Brackets</p> <p>COLOURS: Standard - High Gloss Black Optional Colours - Brown, Forest Green & Matt Black Custom Colours Available Upon Request.</p>
---	---

<p>The following note shall apply to all drawings and associated documents:</p> <p>1. Copyright of this drawing and design is reserved by the Designer & European Wrought Iron Works Ltd. The drawing and all associated documents are an instrument of service by the Designer & European Wrought Iron Works Ltd. The drawing and the information contained therein may not be reproduced in whole or in part without prior written or verbal permission of the designer or European Wrought Iron Works Ltd.</p> <p>2. Drawings are not to be scaled for construction. All existing site conditions and dimensions required to perform the work are to be verified and any discrepancies are to be reported to the designer & European Wrought Iron Works Ltd.</p> <p>3. These drawings are not to be used for construction unless noted below as "Issued for Construction"</p> <p>4. All work to be carried out in conformance with the Code and Bylaws of the authorities having jurisdiction.</p> <p>5. The Designer of these plans and specifications gives no warranty or representation to any party about the constructability of the item represented by them.</p>	<p>CONFIDENTIAL: NOT TO BE DISCLOSED OR REPRODUCED</p> <p>WITHOUT THE WRITTEN PERMISSION OF EUROPEAN WROUGHT IRON WORKS LTD.</p>	<p>TOLERANCES INCHES UNLESS OTHERWISE NOTED</p> <p>X.XXX" ±0.005"</p> <p>X.XX" ±0.05"</p> <p>X.X" ±0.25"</p> <p>FRACTIONAL ±1/16"</p> <p>ANGULAR ±1°</p>	<p>DO NOT MODIFY OR SCALE DRAWING</p> <p>PROJECT TITLE:</p>	<p>DRAWING & DESIGN REMAIN THE PROPERTY OF EUROPEAN WROUGHT IRON WORKS LTD.</p>	
<p>TITLE: Royalty Collection Prince</p>	<p>SCALE: NTS.</p> <p>DATE DRAWN: June 2015</p> <p>DRAWN BY: DCM</p>	<p>DESIGN: P.D.</p> <p>SHEET NO: 4</p>	<p>FINISH: Custom</p> <p>DRAWING NUMBER: RC-04L</p>	<p>REV 1- A</p>	

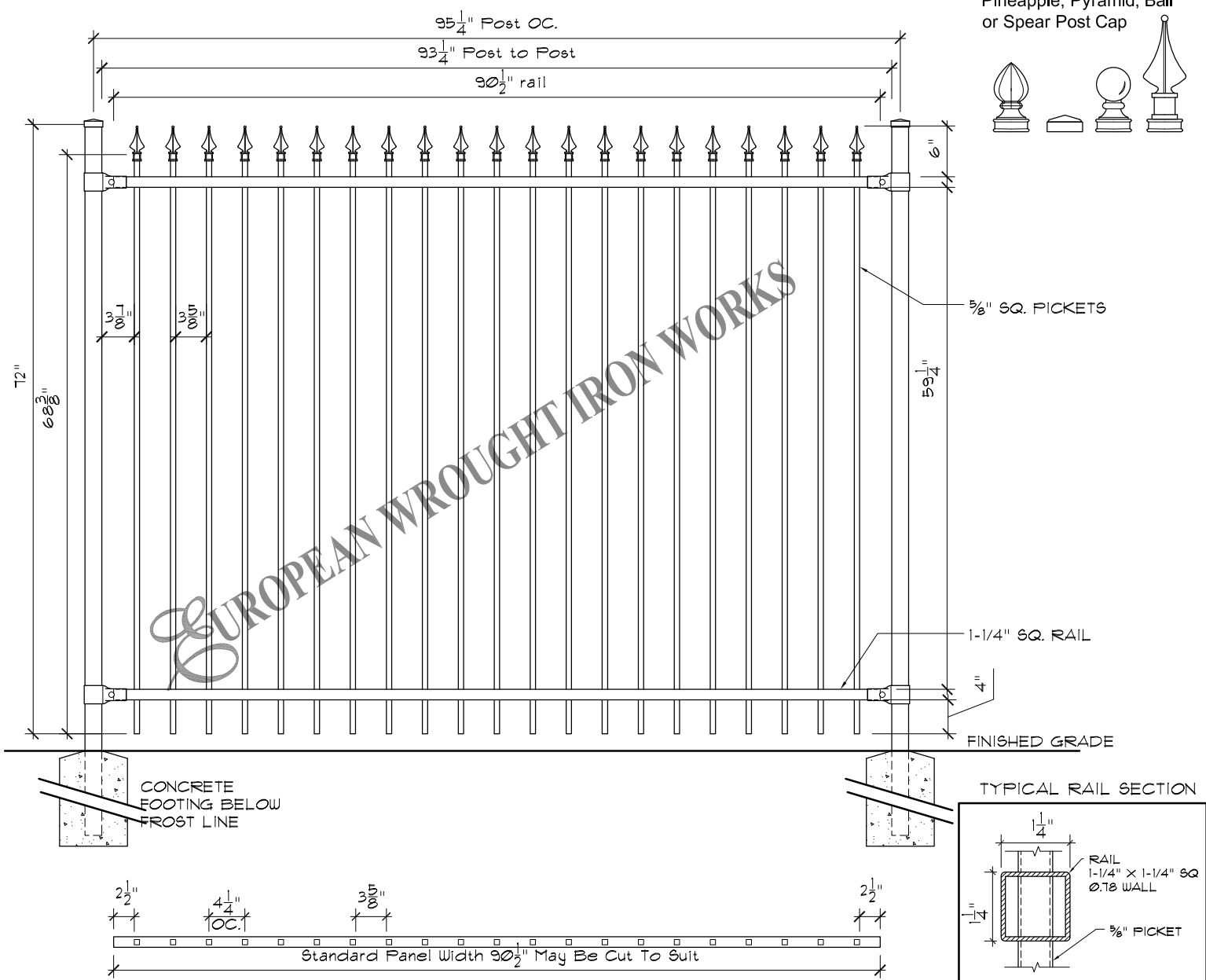

Specifications

<p>POST, RAILS & PICKETS: Cold Formed Steel Tubing Interior And Exterior Galvalume Coating Chromate Conversion Coating Electrostatically Applied Thermally Bonded Polyester Powder Coating Minimum Film Thickness 2.5 Mils</p> <p>POSTS: 2" x 2" (51mm x 51mm) 16 Gauge Standard Post Spacing 97-1/8" (2466mm) OC.</p> <p>POST CAP: Pyramid, Ball or Spear</p> <p>RAILS: 1-1/4" x 1-1/4" (32mm x 32mm) 14 Gauge</p> <p>PICKETS: 5/8" x 5/8" (15mm x 15mm) 16 Gauge</p>	<p>FITTINGS: 15 Gauge Stamp Forged Factory Finish. As Above</p> <p>WELDS: Stainless Steel</p> <p>STANDARD PANEL WIDTH: 91-1/2" (2324mm)</p> <p>AVAILABLE PANEL HEIGHTS: 48" (1219mm) (plus cap if applicable) 60" (1524mm) 72" (1828mm)</p> <p>NOTE: Tamper Proof Nut Available For Brackets</p> <p>COLOURS: Standard - High Gloss Black Optional Colours - Brown, Forest Green & Matt Black Custom Colours Available Upon Request.</p>
---	---

<p>The following note shall apply to all drawings and associated documents:</p> <p>1. Copyright of this drawing and design is reserved by the Designer & European Wrought Iron Works Ltd. The drawing and all associated documents are an instrument of service by the Designer & European Wrought Iron Works Ltd. The drawing and the information contained therein may not be reproduced in whole or in part without prior written or verbal permission of the designer or European Wrought Iron Works Ltd.</p> <p>2. Drawings are not to be scaled for construction. All existing site conditions and dimensions required to perform the work are to be verified and any discrepancies are to be reported to the designer & European Wrought Iron Works Ltd.</p> <p>3. These drawings are not to be used for construction unless noted below as "Issued for Construction"</p> <p>4. All work to be carried out in conformance with the Code and Bylaws of the authorities having jurisdiction.</p> <p>5. The Designer of these plans and specifications gives no warranty or representation to any party about the constructability of the item represented by them.</p>	<p>CONFIDENTIAL: NOT TO BE DISCLOSED OR REPRODUCED</p> <p>WITHOUT THE WRITTEN PERMISSION OF EUROPEAN WROUGHT IRON WORKS LTD.</p>	<p>TOLERANCES INCHES UNLESS OTHERWISE NOTED X.XXX" ±0.005" X.XX" ±0.05" X.X" ±0.25" FRACTIONAL ±1/16" ANGULAR ±1°</p>	<p>DO NOT MODIFY OR SCALE DRAWING</p> <p>PROJECT TITLE:</p>	<p>DRAWING & DESIGN REMAIN THE PROPERTY OF EUROPEAN WROUGHT IRON WORKS LTD.</p>	
<p>TITLE: Royalty Collection <i>Prince Custom with Circle PS.</i></p>	<p>SCALE: NTS.</p> <p>DATE DRAWN: June 2015</p> <p>DRAWN BY: DCM</p>	<p>DESIGN: P.D.</p> <p>SHEET NO: 4m</p>	<p>FINISH: Custom</p> <p>DRAWING NUMBER: RC-04m</p>	<p>REV: 1-</p> <p>A</p>	

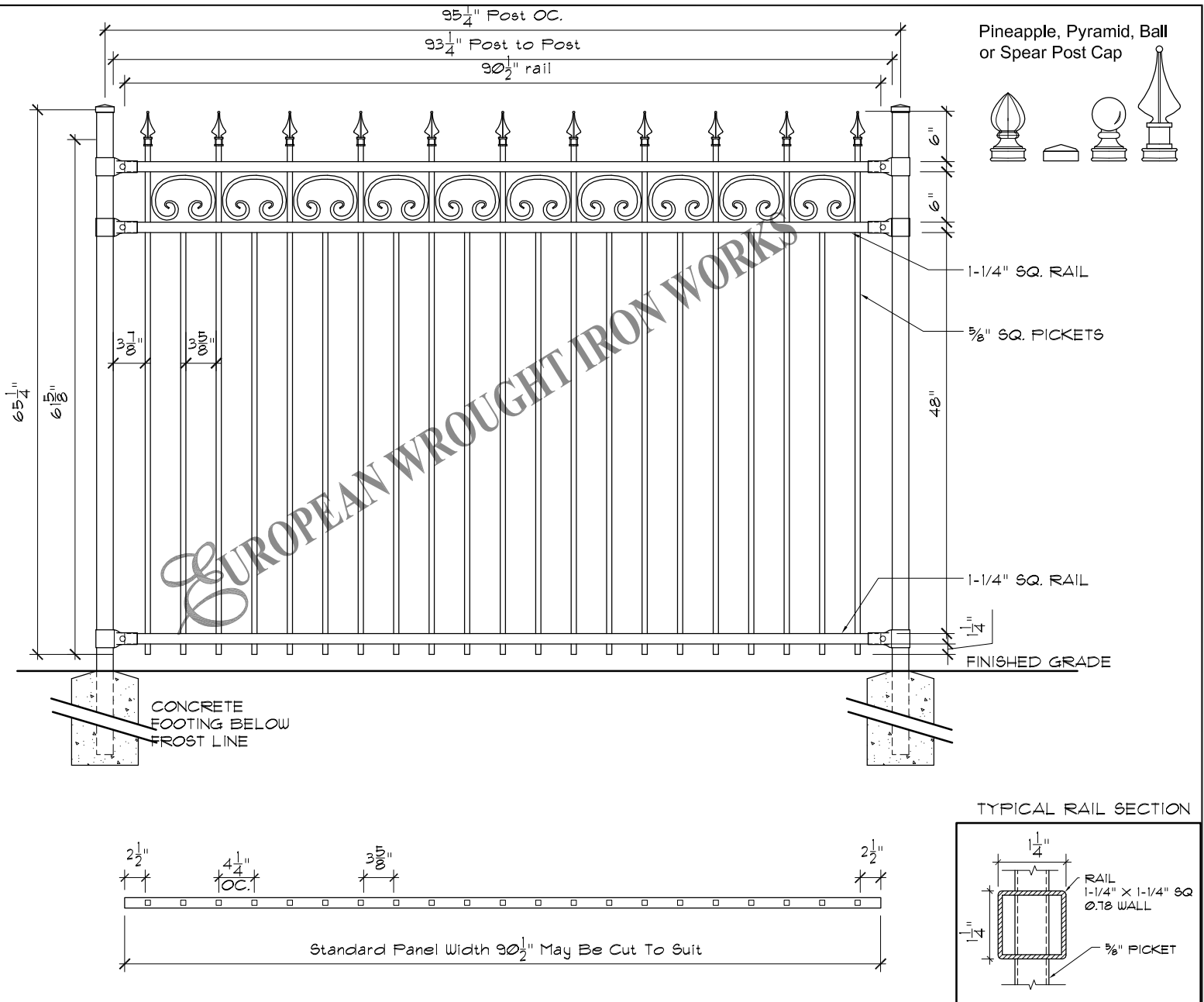

Specifications

<p>POST, RAILS & PICKETS: Cold Formed Steel Tubing Interior And Exterior Galvalume Coating Chromate Conversion Coating Electrostatically Applied Thermally Bonded Polyester Powder Coating Minimum Film Thickness 2.5 Mils</p> <p>POSTS: 2" x 2" (51mm x 51mm) 16 Gauge Standard Post Spacing 97-1/8" (2466mm) OC.</p> <p>POST CAP: Pyramid, Ball or Spear</p> <p>RAILS: 1-1/4" x 1-1/4" (32mm x 32mm) 14 Gauge</p> <p>PICKETS: 5/8" x 5/8" (15mm x 15mm) 16 Gauge</p>	<p>FITTINGS: 15 Gauge Stamp Forged Factory Finish. As Above</p> <p>WELDS: Stainless Steel</p> <p>STANDARD PANEL WIDTH: 91-1/2" (2324mm)</p> <p>AVAILABLE PANEL HEIGHTS: 48" (1219mm) (plus cap if applicable) 60" (1524mm) 72" (1828mm)</p> <p>NOTE: Tamper Proof Nut Available For Brackets</p> <p>COLOURS: Standard - High Gloss Black Optional Colours - Brown, Forest Green & Matt Black Custom Colours Available Upon Request.</p>
---	---

The following note shall apply to all drawings and associated documents:

- Copyright of this drawing and design is reserved by the Designer & European Wrought Iron Works Ltd. The drawing and all associated documents are an instrument of service by the Designer & European Wrought Iron Works Ltd. The drawing and the information contained therein may not be reproduced in whole or in part without prior written or verbal permission of the designer or European Wrought Iron Works Ltd.
- Drawings are not to be scaled for construction. All existing site conditions and dimensions required to perform the work are to be verified and any discrepancies are to be reported to the designer & European Wrought Iron Works Ltd.
- These drawings are not to be used for construction unless noted below as "Issued for Construction"
- All work to be carried out in conformance with the Code and Bylaws of the authorities having jurisdiction.
- The Designer of these plans and specifications gives no warranty or representation to any party about the constructability of the item represented by them.

CONFIDENTIAL: NOT TO BE DISCLOSED OR REPRODUCED

EUROPEAN
WROUGHT IRON WORKS

WITHOUT THE WRITTEN PERMISSION OF EUROPEAN WROUGHT IRON WORKS LTD.

TITLE:
Royalty Collection
Prince Custom with Circle PS.

TOLERANCES
INCHES
UNLESS OTHERWISE NOTED
X.XXX" ±0.005"
X.XX" ±0.05"
X.X" ±0.25"
FRACTIONAL ±1/16"
ANGULAR ±1°

SCALE: NTS.

DATE DRAWN: June 2015

DRAWN BY: DCM

DO NOT MODIFY OR SCALE DRAWING

PROJECT TITLE:

DESIGN: P.D.

SHEET NO.: 4n

DRAWING & DESIGN REMAIN THE PROPERTY OF EUROPEAN WROUGHT IRON WORKS LTD.

FINISH: Custom

DRAWING NUMBER: RC-04n

REV
1- A

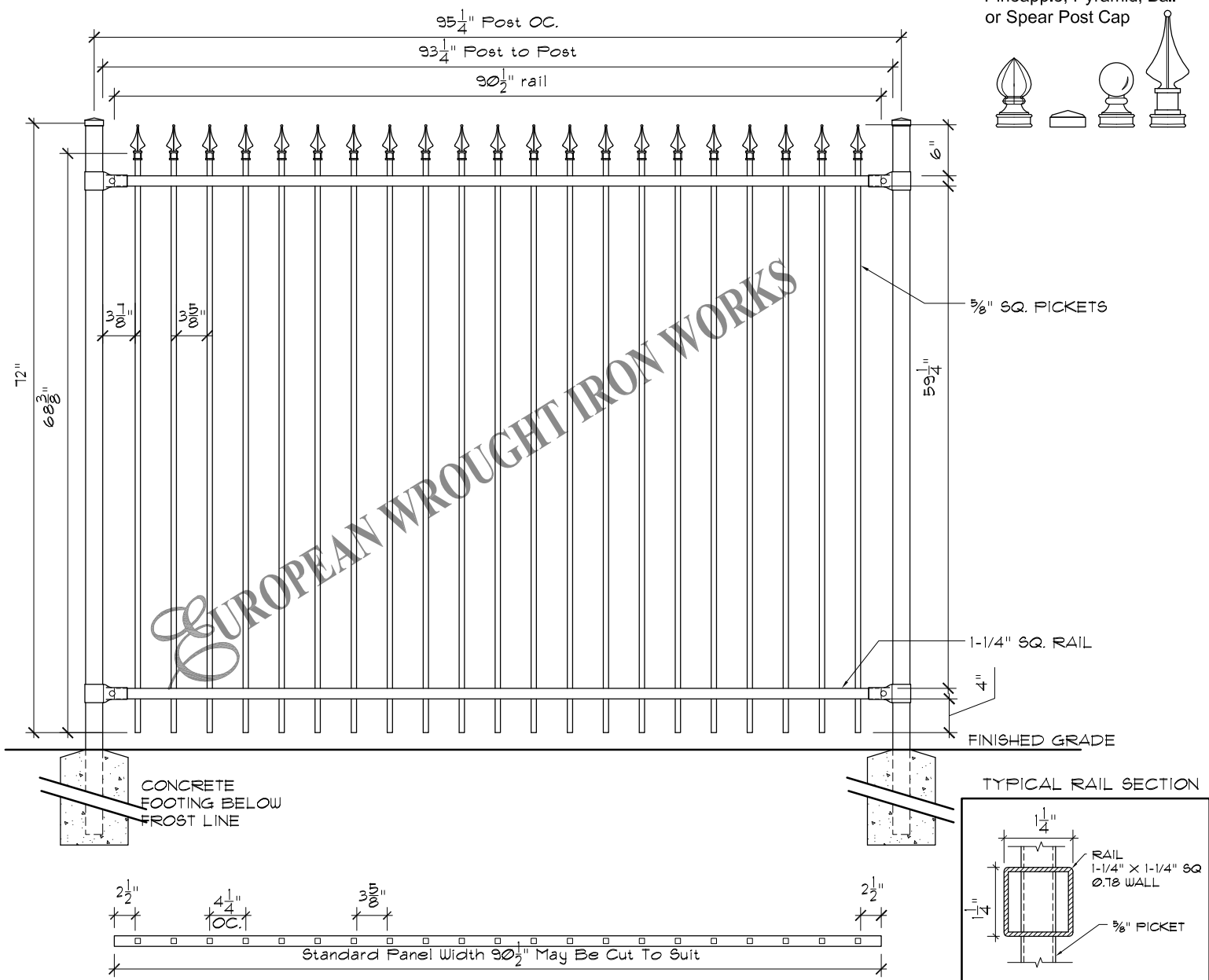

Pineapple, Pyramid, Ball or Spear Post Cap

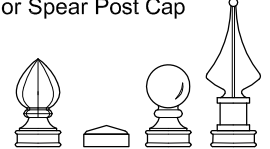

EUROPEAN WROUGHT IRON WORKS

Specifications

<p>POST, RAILS & PICKETS: Cold Formed Steel Tubing Interior And Exterior Galvalume Coating Chromate Conversion Coating Electrostatically Applied Thermally Bonded Polyester Powder Coating Minimum Film Thickness 2.5 Mils</p> <p>POSTS: 2" x 2" (51mm x 51mm) 16 Gauge Standard Post Spacing 97-1/8" (2466mm) OC.</p> <p>POST CAP: Pyramid, Ball or Spear</p> <p>RAILS: 1-1/4" x 1-1/4" (32mm x 32mm) 14 Gauge</p> <p>PICKETS: 5/8" x 5/8" (15mm x 15mm) 16 Gauge</p>	<p>FITTINGS: 15 Gauge Stamp Forged Factory Finish. As Above</p> <p>WELDS: Stainless Steel</p> <p>STANDARD PANEL WIDTH: 91-1/2" (2324mm)</p> <p>AVAILABLE PANEL HEIGHTS: 48" (1219mm) (plus cap if applicable) 60" (1524mm) 72" (1828mm)</p> <p>NOTE: Tamper Proof Nut Available For Brackets</p> <p>COLOURS: Standard - High Gloss Black Optional Colours - Brown, Forest Green & Matt Black Custom Colours Available Upon Request.</p>
---	---

<p>The following note shall apply to all drawings and associated documents:</p> <p>1. Copyright of this drawing and design is reserved by the Designer & European Wrought Iron Works Ltd. The drawing and all associated documents are an instrument of service by the Designer & European Wrought Iron Works Ltd. The drawing and the information contained therein may not be reproduced in whole or in part without prior written or verbal permission of the designer or European Wrought Iron Works Ltd.</p> <p>2. Drawings are not to be scaled for construction. All existing site conditions and dimensions required to perform the work are to be verified and any discrepancies are to be reported to the designer & European Wrought Iron Works Ltd.</p> <p>3. These drawings are not to be used for construction unless noted below as "Issued for Construction"</p> <p>4. All work to be carried out in conformance with the Code and Bylaws of the authorities having jurisdiction.</p> <p>5. The Designer of these plans and specifications gives no warranty or representation to any party about the constructability of the item represented by them.</p>	<p style="font-size: 8px;">CONFIDENTIAL: NOT TO BE DISCLOSED OR REPRODUCED</p> <p style="font-size: 8px;">WITHOUT THE WRITTEN PERMISSION OF EUROPEAN WROUGHT IRON WORKS LTD.</p>	<p>TOLERANCES INCHES UNLESS OTHERWISE NOTED ".XXX" ±0.005" ".XX" ±0.05" ".X" ±0.25" FRACTIONAL ±1/16" ANGULAR ±1°</p>	<p>DO NOT MODIFY OR SCALE DRAWING</p> <p>PROJECT TITLE:</p>	<p>DRAWING & DESIGN REMAIN THE PROPERTY OF EUROPEAN WROUGHT IRON WORKS LTD.</p>	<p>SCALE: NTS.</p> <p>DATE DRAWN: June 2015</p> <p>DRAWN BY: DCM</p>	<p>DESIGN: P.D.</p> <p>SHEET NO: 40</p>	<p>FINISH: Custom</p> <p>DRAWING NUMBER: RC-040</p>	<p>REV 1-</p> <p>A</p>
<p>TITLE: Royalty Collection <i>Prince Custom with Circle PS.</i></p>								

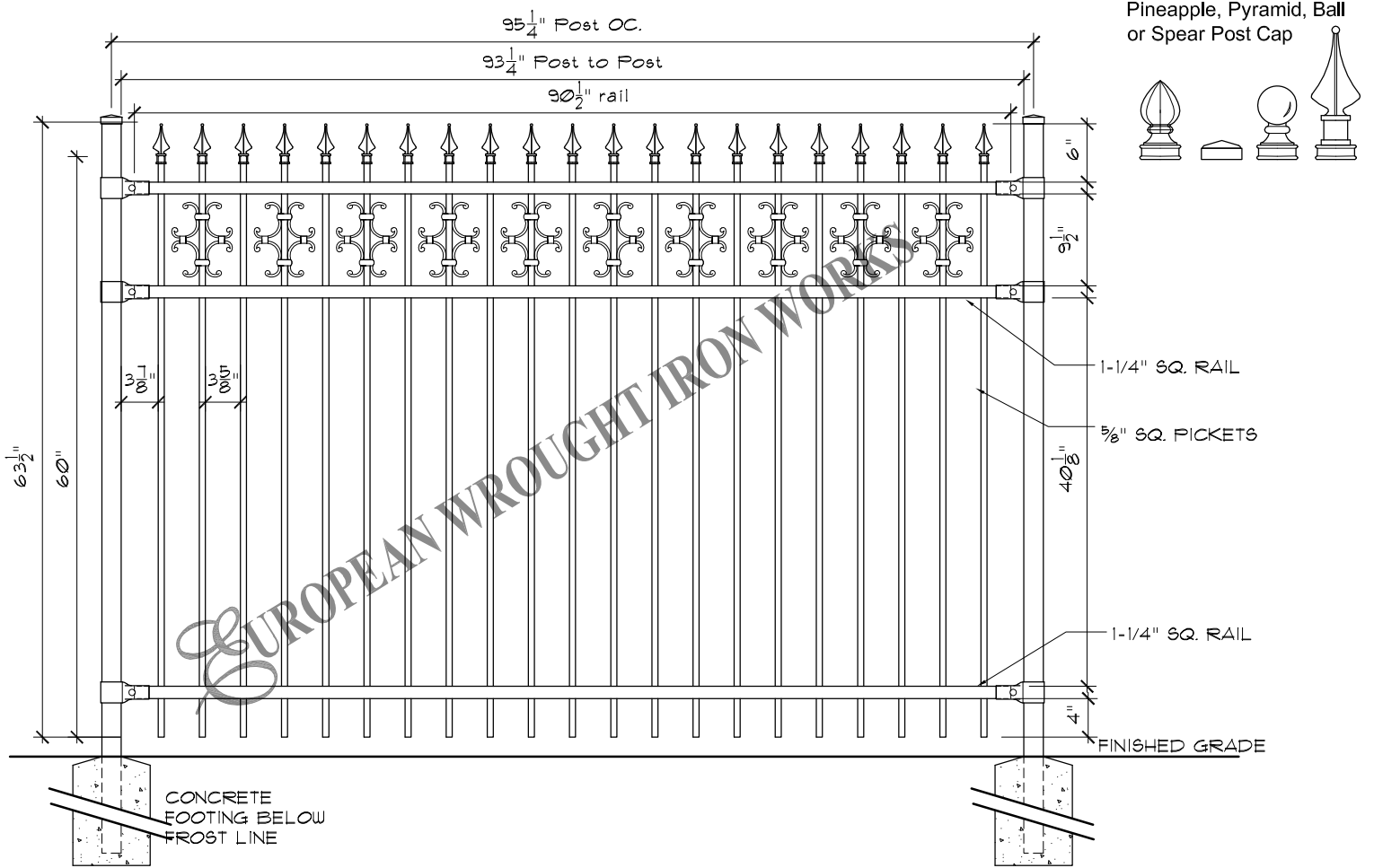

Pineapple, Pyramid, Ball or Spear Post Cap

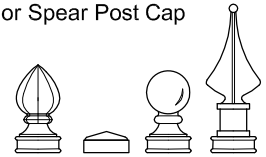

TYPICAL RAIL SECTION

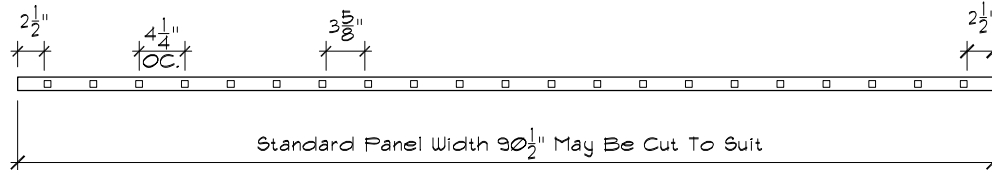
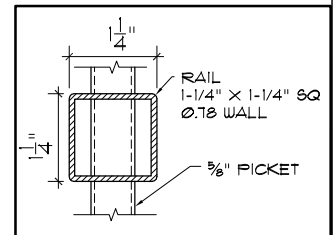

Standard Panel Width 90 1/2" May Be Cut To Suit

Specifications

<p>POST, RAILS & PICKETS: Cold Formed Steel Tubing Interior And Exterior Galvalume Coating Chromate Conversion Coating Electrostatically Applied Thermally Bonded Polyester Powder Coating Minimum Film Thickness 2.5 Mils</p> <p>POSTS: 2" x 2" (51mm x 51mm) 16 Gauge Standard Post Spacing 97-1/8" (2466mm) OC.</p> <p>POST CAP: Pyramid, Ball or Spear</p> <p>RAILS: 1-1/4" x 1-1/4" (32mm x 32mm) 14 Gauge</p> <p>PICKETS: 5/8" x 5/8" (15mm x 15mm) 16 Gauge</p>	<p>FITTINGS: 15 Gauge Stamp Forged Factory Finish. As Above</p> <p>WELDS: Stainless Steel</p> <p>STANDARD PANEL WIDTH: 91-1/2" (2324mm)</p> <p>AVAILABLE PANEL HEIGHTS: 48" (1219mm) (plus cap if applicable) 60" (1524mm) 72" (1828mm)</p> <p>NOTE: Tamper Proof Nut Available For Brackets</p> <p>COLOURS: Standard - High Gloss Black Optional Colours - Brown, Forest Green & Matt Black</p> <p>Custom Colours Available Upon Request.</p>
---	--

The following note shall apply to all drawings and associated documents:
 1. Copyright of this drawing and design is reserved by the Designer & European Wrought Iron Works Ltd. The drawing and all associated documents are an instrument of service by the Designer & European Wrought Iron Works Ltd. The drawing and the information contained therein may not be reproduced in whole or in part without prior written or verbal permission of the designer or European Wrought Iron Works Ltd.
 2. Drawings are not to be scaled for construction. All existing site conditions and dimensions required to perform the work are to be verified and any discrepancies are to be reported to the designer & European Wrought Iron Works Ltd.
 3. These drawings are not to be used for construction unless noted below as "Issued for Construction"
 4. All work to be carried out in conformance with the Code and Bylaws of the authorities having jurisdiction.
 5. The Designer of these plans and specifications gives no warranty or representation to any party about the constructability of the item represented by them.

CONFIDENTIAL: NOT TO BE DISCLOSED OR REPRODUCED

EUROPEAN
WROUGHT IRON WORKS

WITHOUT THE WRITTEN PERMISSION OF EUROPEAN WROUGHT IRON WORKS LTD.

TITLE:
Royalty Collection
Prince Custom with Circle PS.

TOLERANCES
INCHES
UNLESS OTHERWISE NOTED
X.XXX" ±0.005"
X.XX" ±0.05"
X.X" ±0.25"
FRACTIONAL ±1/16"
ANGULAR ±1°

SCALE: NTS.

DATE DRAWN: June 2015

DRAWN BY: DCM

DO NOT MODIFY OR SCALE DRAWING

PROJECT TITLE:

DESIGN: P.D.

SHEET NO: 4p

DRAWING & DESIGN REMAIN THE PROPERTY OF EUROPEAN WROUGHT IRON WORKS LTD.

FINISH: Custom

DRAWING NUMBER: RC-04p

REV 1- **A**

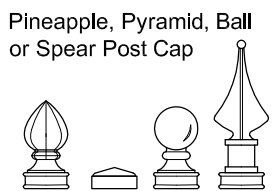
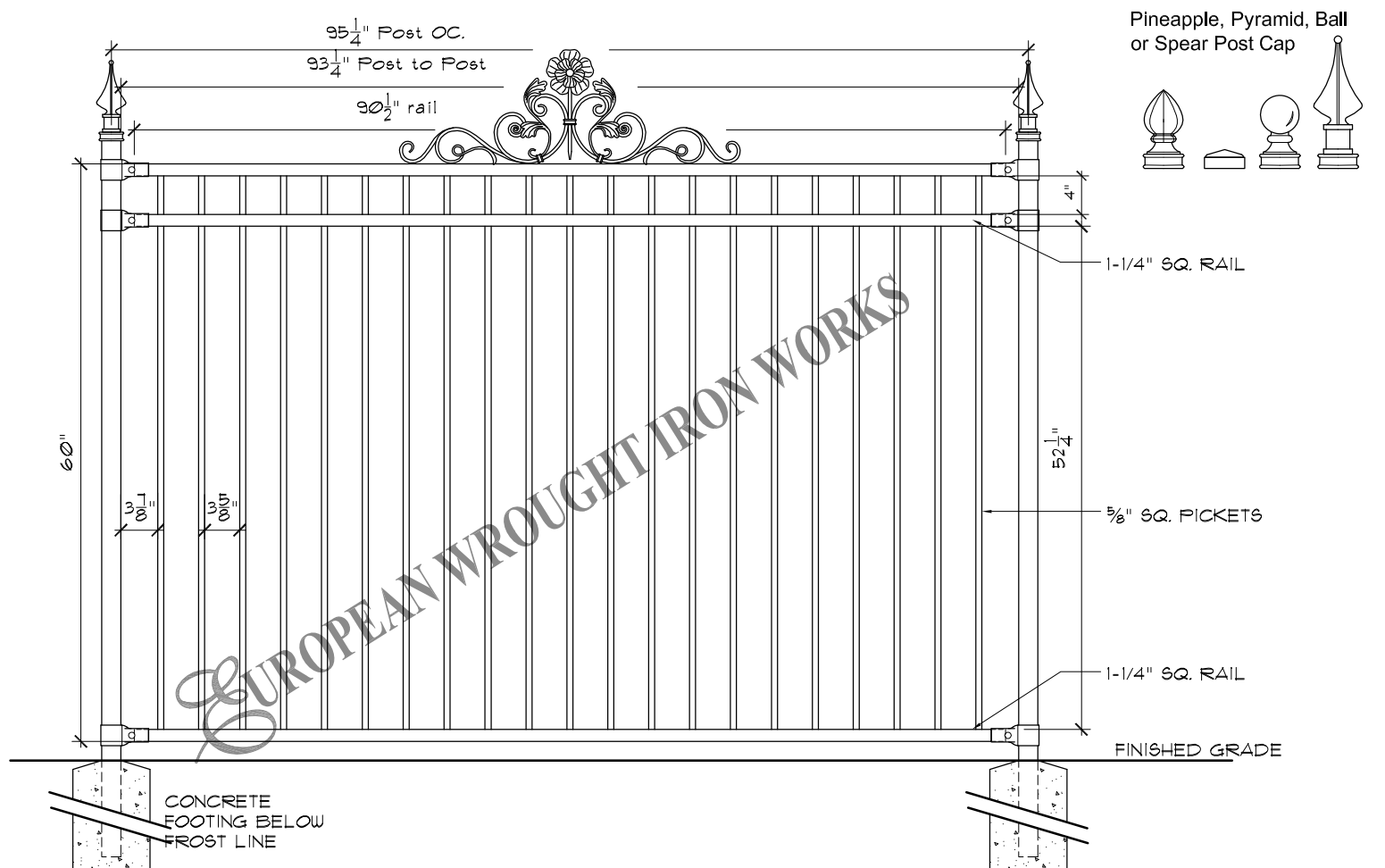

EUROPEAN WROUGHT IRON WORKS

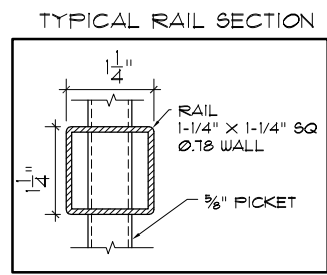
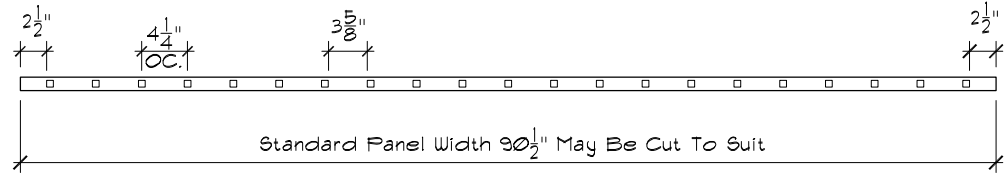

Specifications

<p>POST, RAILS & PICKETS: Cold Formed Steel Tubing Interior And Exterior Galvalume Coating Chromate Conversion Coating Electrostatically Applied Thermally Bonded Polyester Powder Coating Minimum Film Thickness 2.5 Mils</p> <p>POSTS: 2" x 2" (51mm x 51mm) 16 Gauge Standard Post Spacing 97-1/8" (2466mm) OC.</p> <p>POST CAP: Pyramid, Ball or Spear</p> <p>RAILS: 1-1/4" x 1-1/4" (32mm x 32mm) 14 Gauge</p> <p>PICKETS: 5/8" x 5/8" (15mm x 15mm) 16 Gauge</p>	<p>FITTINGS: 15 Gauge Stamp Forged Factory Finish. As Above</p> <p>WELDS: Stainless Steel</p> <p>STANDARD PANEL WIDTH: 91-1/2" (2324mm)</p> <p>AVAILABLE PANEL HEIGHTS: 48" (1219mm) (plus cap if applicable) 60" (1524mm) 72" (1828mm)</p> <p>NOTE: Tamper Proof Nut Available For Brackets</p> <p>COLOURS: Standard - High Gloss Black Optional Colours - Brown, Forest Green & Matt Black Custom Colours Available Upon Request.</p>
---	---

<p>The following note shall apply to all drawings and associated documents:</p> <p>1. Copyright of this drawing and design is reserved by the Designer & European Wrought Iron Works Ltd. The drawing and all associated documents are an instrument of service by the Designer & European Wrought Iron Works Ltd. The drawing and the information contained therein may not be reproduced in whole or in part without prior written or verbal permission of the designer or European Wrought Iron Works Ltd.</p> <p>2. Drawings are not to be scaled for construction. All existing site conditions and dimensions required to perform the work are to be verified and any discrepancies are to be reported to the designer & European Wrought Iron Works Ltd.</p> <p>3. These drawings are not to be used for construction unless noted below as "Issued for Construction"</p> <p>4. All work to be carried out in conformance with the Code and Bylaws of the authorities having jurisdiction.</p> <p>5. The Designer of these plans and specifications gives no warranty or representation to any party about the constructability of the item represented by them.</p>	<p style="font-size: 8px;">CONFIDENTIAL: NOT TO BE DISCLOSED OR REPRODUCED</p> <p style="font-size: 8px;">WITHOUT THE WRITTEN PERMISSION OF EUROPEAN WROUGHT IRON WORKS LTD.</p>	<p>TOLERANCES INCHES UNLESS OTHERWISE NOTED X.XXX" ±0.005" X.XX" ±0.05" X.X" ±0.25" FRACTIONAL ±1/16" ANGULAR ±1°</p>	<p>DO NOT MODIFY OR SCALE DRAWING</p> <p>PROJECT TITLE:</p>	<p>DRAWING & DESIGN REMAIN THE PROPERTY OF EUROPEAN WROUGHT IRON WORKS LTD.</p>	
<p>TITLE: Royalty Collection <i>Lord Custom with Crown</i></p>	<p>SCALE: NTS.</p> <p>DATE DRAWN: June 2015</p> <p>DRAWN BY: DCM</p>	<p>DESIGN: P.D.</p> <p>SHEET NO: 5i</p>	<p>FINISH: Custom</p> <p>DRAWING NUMBER: RC-05i</p>	<p>REV 1- A</p>	

Pineapple, Pyramid, Ball or Spear Post Cap

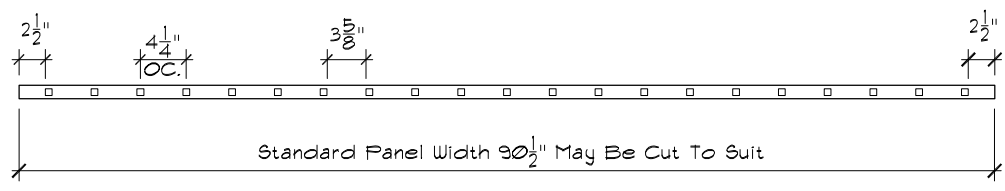
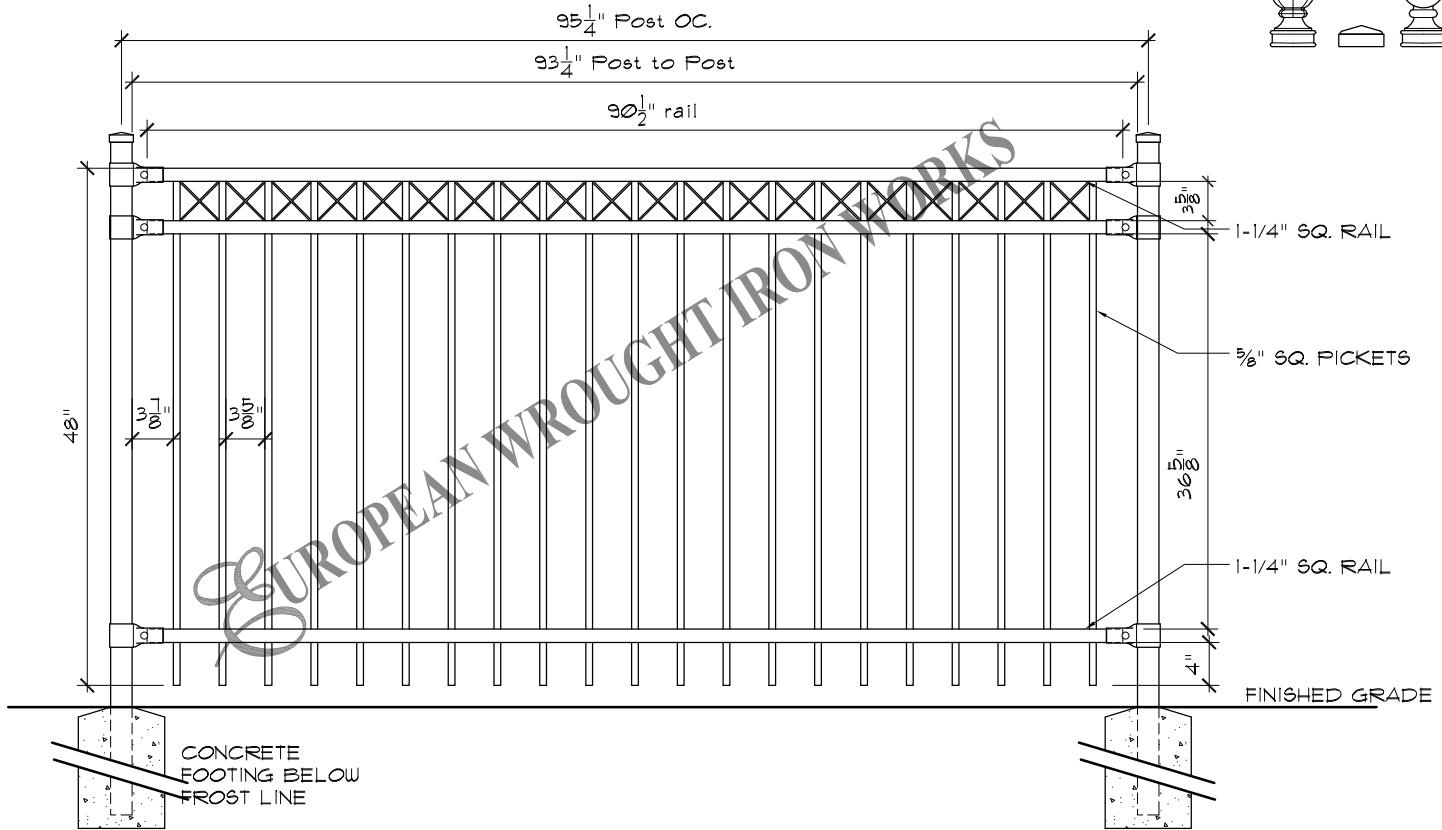
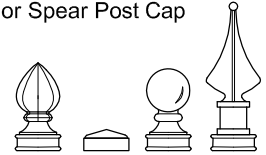

TYPICAL RAIL SECTION

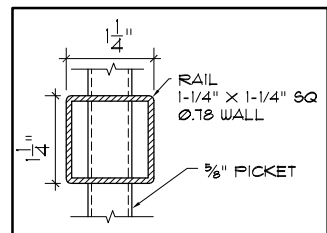

Specifications

<p>POST, RAILS & PICKETS: Cold Formed Steel Tubing Interior And Exterior Galvalume Coating Chromate Conversion Coating Electrostatically Applied Thermally Bonded Polyester Powder Coating Minimum Film Thickness 2.5 Mils</p> <p>POSTS: 2" x 2" (51mm x 51mm) 16 Gauge Standard Post Spacing 97-1/8" (2466mm) OC.</p> <p>POST CAP: Pyramid, Ball or Spear</p> <p>RAILS: 1-1/4" x 1-1/4" (32mm x 32mm) 14 Gauge</p> <p>PICKETS: 5/8" x 5/8" (15mm x 15mm) 16 Gauge</p>	<p>FITTINGS: 15 Gauge Stamp Forged Factory Finish. As Above</p> <p>WELDS: Stainless Steel</p> <p>STANDARD PANEL WIDTH: 91-1/2" (2324mm)</p> <p>AVAILABLE PANEL HEIGHTS: 48" (1219mm) (plus cap if applicable) 60" (1524mm) 72" (1828mm)</p> <p>NOTE: Tamper Proof Nut Available For Brackets</p> <p>COLOURS: Standard - High Gloss Black Optional Colours - Brown, Forest Green & Matt Black Custom Colours Available Upon Request.</p>
---	---

The following note shall apply to all drawings and associated documents:
 1. Copyright of this drawing and design is reserved by the Designer & European Wrought Iron Works Ltd. The drawing and all associated documents are an instrument of service by the Designer & European Wrought Iron Works Ltd. The drawing and the information contained therein may not be reproduced in whole or in part without prior written or verbal permission of the designer or European Wrought Iron Works Ltd.
 2. Drawings are not to be scaled for construction. All existing site conditions and dimensions required to perform the work are to be verified and any discrepancies are to be reported to the designer & European Wrought Iron Works Ltd.
 3. These drawings are not to be used for construction unless noted below as "Issued for Construction"
 4. All work to be carried out in conformance with the Code and Bylaws of the authorities having jurisdiction.
 5. The Designer of these plans and specifications gives no warranty or representation to any party about the constructability of the item represented by them.

CONFIDENTIAL: NOT TO BE DISCLOSED OR REPRODUCED

WITHOUT THE WRITTEN PERMISSION OF EUROPEAN WROUGHT IRON WORKS LTD.

TITLE:
Royalty Collection
Lord Custom with X's

TOLERANCES INCHES UNLESS OTHERWISE NOTED	
X.XXX" ±0.005"	
X.XX" ±0.05"	
X.X" ±0.25"	
FRACTIONAL ±1/16"	
ANGULAR ±1°	
SCALE: NTS.	DATE DRAWN: June 2015
	DRAWN BY: DCM

DO NOT MODIFY OR SCALE DRAWING	PROJECT TITLE:
DESIGN: P.D.	SHEET NO: 5j

DRAWING & DESIGN REMAIN THE PROPERTY OF EUROPEAN WROUGHT IRON WORKS LTD.	
FINISH: Custom	REV 1- A
DRAWING NUMBER: RC-05i	

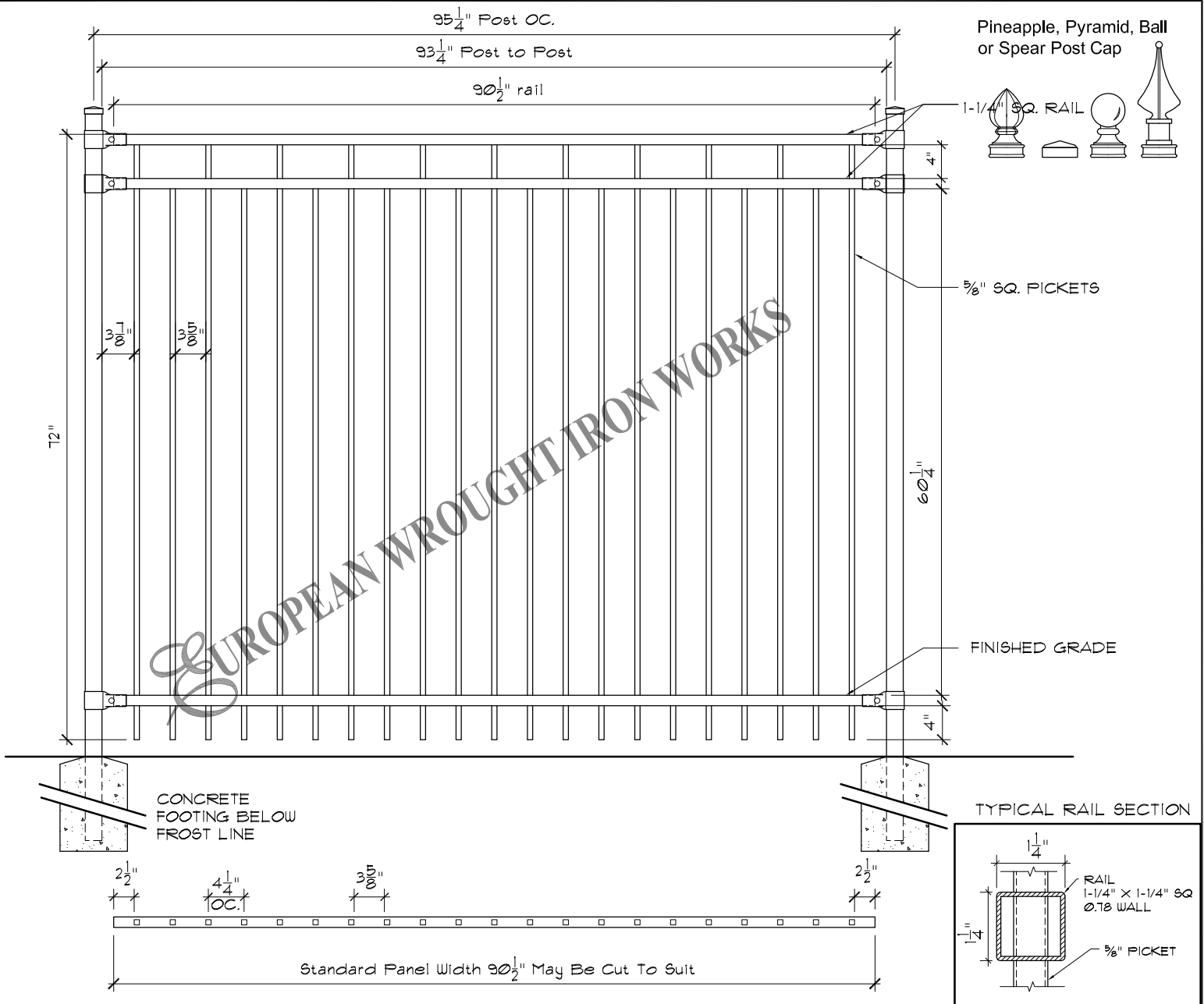

Specifications

POST, RAILS & PICKETS:	Cold Formed Steel Tubing Interior And Exterior Galvalume Coating Chromate Conversion Coating Electrostatically Applied Thermally Bonded Polyester Powder Coating Minimum Film Thickness 2.5 Mils	FITTINGS:	15 Gauge Stamp Forged Factory Finish. As Above
POSTS:	2" x 2" (51mm x 51mm) 16 Gauge Standard Post Spacing 97-1/8" (2466mm) OC.	WELDS:	Stainless Steel
POST CAP:	Pyramid, Ball or Spear	STANDARD PANEL WIDTH:	91-1/2" (2324mm)
RAILS:	1-1/4" x 1-1/4" (32mm x 32mm) 14 Gauge	AVAILABLE PANEL HEIGHTS:	48" (1219mm) (plus cap if applicable) 60" (1524mm) 72" (1828mm)
PICKETS:	5/8" x 5/8" (15mm x 15mm) 16 Gauge	NOTE:	Tamper Proof Nut Available For Brackets
		COLOURS:	Standard - High Gloss Black Optional Colours - Brown, Forest Green & Matt Black Custom Colours Available Upon Request.

The following note shall apply to all drawings and associated documents:

- Copyright of this drawing and design is reserved by the Designer & European Wrought Iron Works Ltd. The drawing and all associated documents are an instrument of service by the Designer & European Wrought Iron Works Ltd. The drawing and the information contained therein may not be reproduced in whole or in part without prior written or verbal permission of the designer or European Wrought Iron Works Ltd.
- Drawings are not to be scaled for construction. All existing site conditions and dimensions required to perform the work are to be verified and any discrepancies are to be reported to the designer & European Wrought Iron Works Ltd.
- These drawings are not to be used for construction unless noted below as "Issued for Construction"
- All work to be carried out in conformance with the Code and Bylaws of the authorities having jurisdiction.
- The Designer of these plans and specifications gives no warranty or representation to any party about the constructability of the item represented by them.

CONFIDENTIAL: NOT TO BE DISCLOSED OR REPRODUCED

EUROPEAN
WROUGHT IRON WORKS

TITLE: **Royalty Collection**
Lord Custom with Dbl. Top Rail III

TOLERANCES
INCHES
UNLESS OTHERWISE NOTED
X.XXX" ±0.005"
X.XX" ±0.05"
X.X" ±0.25"
FRACTIONAL ±1/16"
ANGULAR ±1°

SCALE: NTS.
DATE DRAWN: June 2015
DRAWN BY: DCM

DO NOT
MODIFY OR
SCALE DRAWING

PROJECT TITLE:

DESIGN: P.D.
SHEET NO: 5k

DRAWING & DESIGN REMAIN THE PROPERTY OF EUROPEAN WROUGHT IRON WORKS LTD.

FINISH: Custom
DRAWING NUMBER: RC-05k

REV 1- A

Pineapple, Pyramid, Ball or Spear Post Cap

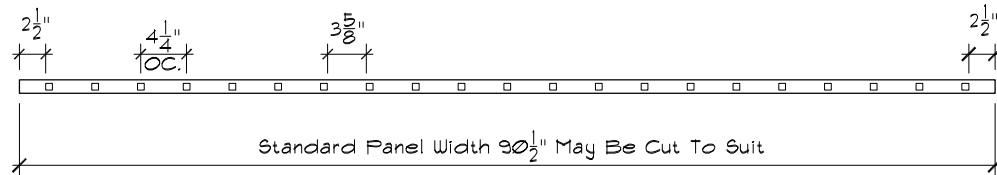
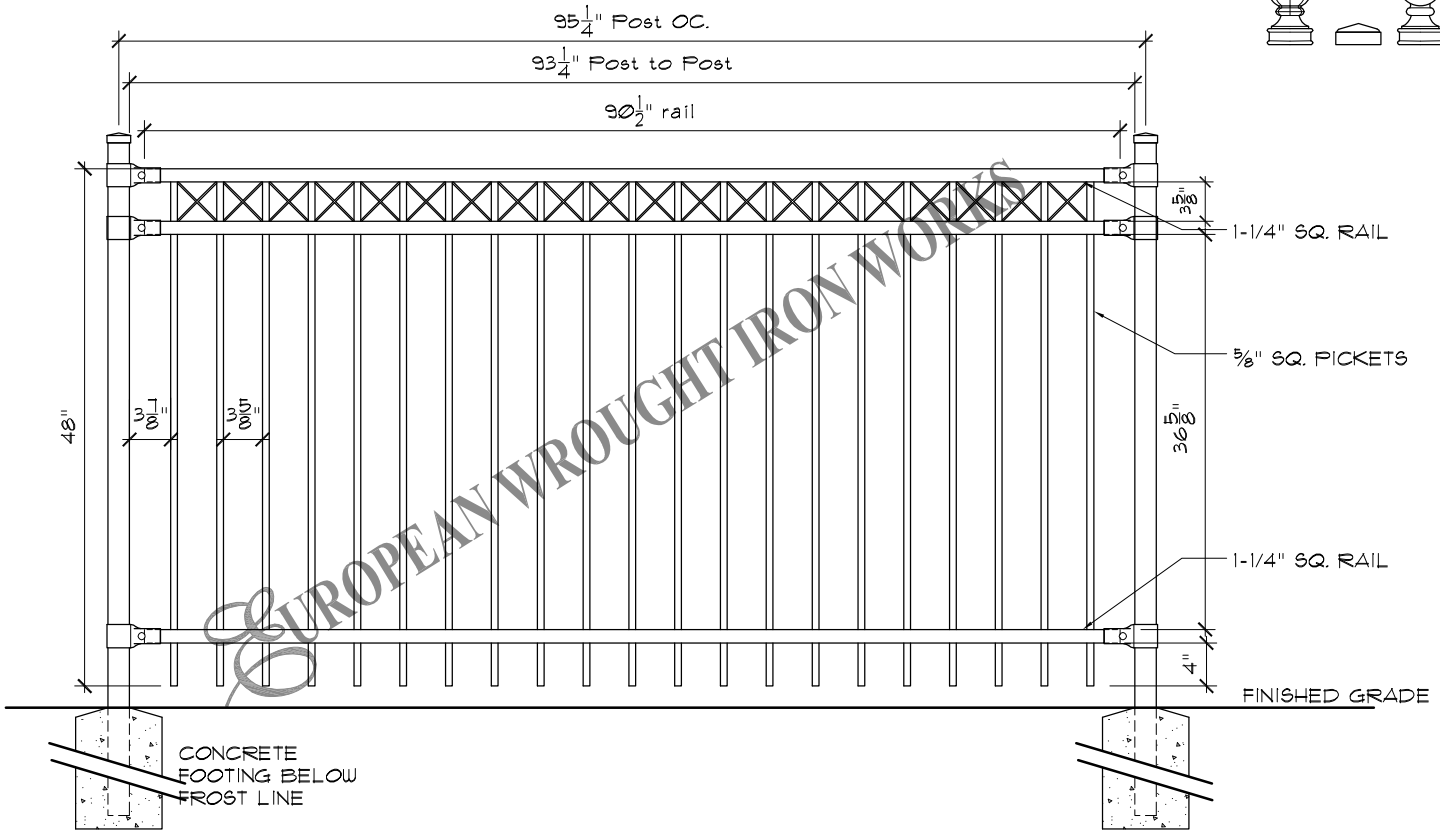
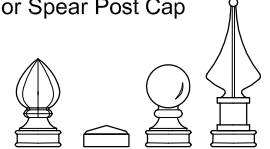

TYPICAL RAIL SECTION

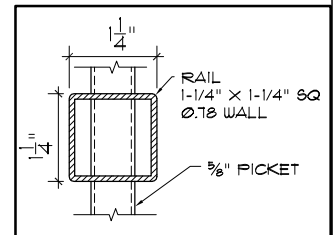

Specifications

POST, RAILS & PICKETS:	Cold Formed Steel Tubing Interior And Exterior Galvalume Coating Chromate Conversion Coating Electrostatically Applied Thermally Bonded Polyester Powder Coating Minimum Film Thickness 2.5 Mils	FITTINGS:	15 Gauge Stamp Forged Factory Finish. As Above
POSTS:	2" x 2" (51mm x 51mm) 16 Gauge Standard Post Spacing 97-1/8" (2466mm) OC.	WELDS:	Stainless Steel
POST CAP:	Pyramid, Ball or Spear	STANDARD PANEL WIDTH:	91-1/2" (2324m)
RAILS:	1-1/4" x 1-1/4" (32mm x 32mm) 14 Gauge	AVAILABLE PANEL HEIGHTS:	48" (1219mm) (plus cap if applicable) 60" (1524mm) 72" (1828mm)
PICKETS:	5/8" x 5/8" (15mm x 15mm) 16 Gauge	NOTE:	Tamper Proof Nut Available For Brackets
		COLOURS:	Standard - High Gloss Black Optional Colours - Brown, Forest Green & Matt Black Custom Colours Available Upon Request.

The following note shall apply to all drawings and associated documents:

- Copyright of this drawing and design is reserved by the Designer & European Wrought Iron Works Ltd. The drawing and all associated documents are an instrument of service by the Designer & European Wrought Iron Works Ltd. The drawing and the information contained therein may not be reproduced in whole or in part without prior written or verbal permission of the designer or European Wrought Iron Works Ltd.
- Drawings are not to be scaled for construction. All existing site conditions and dimensions required to perform the work are to be verified and any discrepancies are to be reported to the designer & European Wrought Iron Works Ltd.
- These drawings are not to be used for construction unless noted below as "Issued for Construction"
- All work to be carried out in conformance with the Code and Bylaws of the authorities having jurisdiction.
- The Designer of these plans and specifications gives no warranty or representation to any party about the constructability of the item represented by them.

CONFIDENTIAL: NOT TO BE DISCLOSED OR REPRODUCED



TITLE: **Royalty Collection**
Lord Custom with Dbl. Top Rail III

TOLERANCES INCHES
UNLESS OTHERWISE NOTED
X.XXX" ±0.005"
X.XX" ±0.05"
X.X" ±0.25"
FRACTIONAL ±1/16"
ANGULAR ±1°

SCALE: NTS.
DATE DRAWN: June 2015
DRAWN BY: DCM

DO NOT MODIFY OR SCALE DRAWING

DRAWING & DESIGN REMAIN THE PROPERTY OF EUROPEAN WROUGHT IRON WORKS LTD.

PROJECT TITLE:

DESIGN: P.D.
SHEET NO: 51

FINISH: Custom
DRAWING NUMBER: RC-051

REV 1- A

Pineapple, Pyramid, Ball or Spear Post Cap

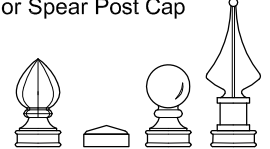

93 1/4" Post to Post

90 1/2" rail

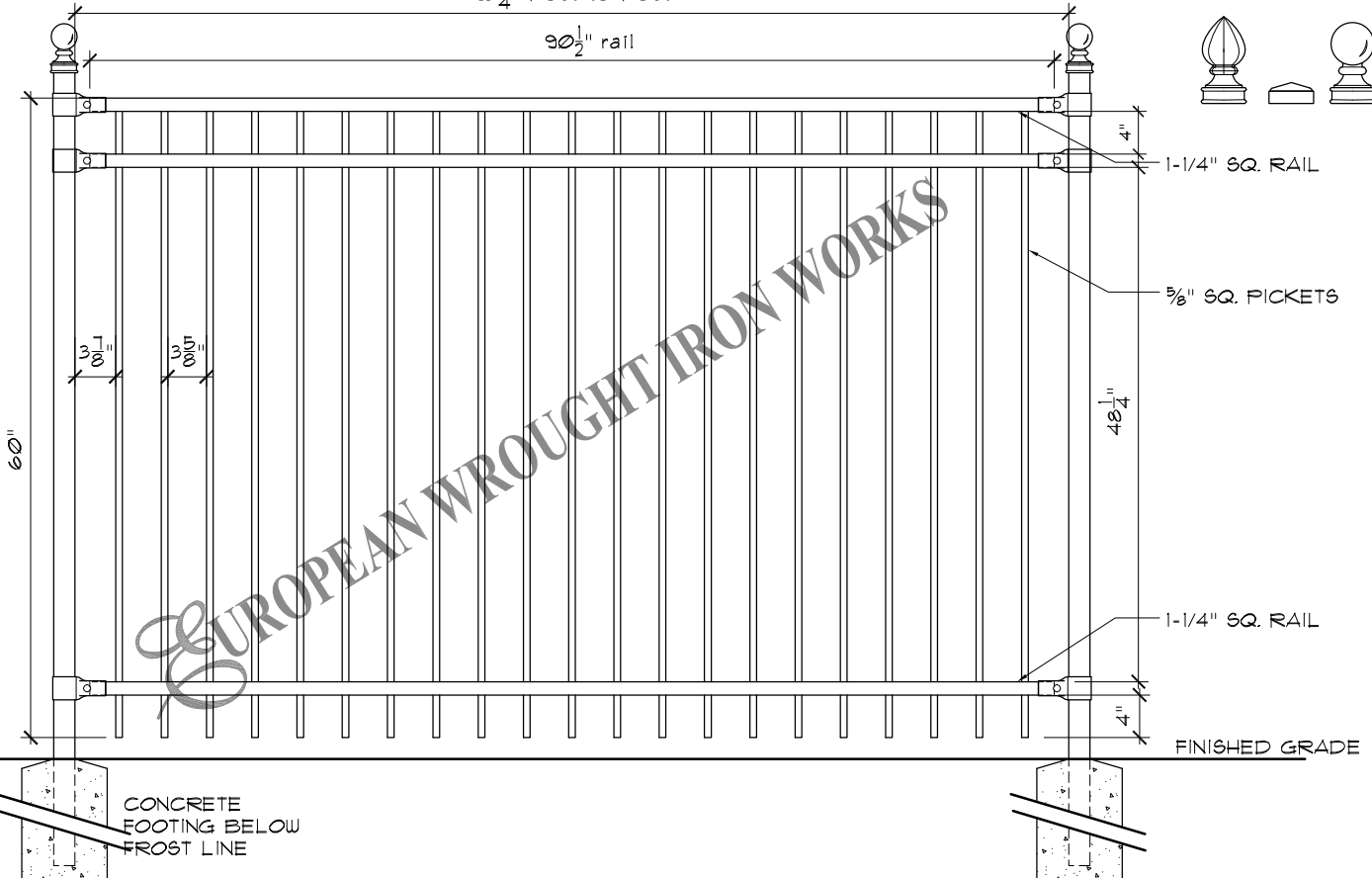

FINISHED GRADE

TYPICAL RAIL SECTION

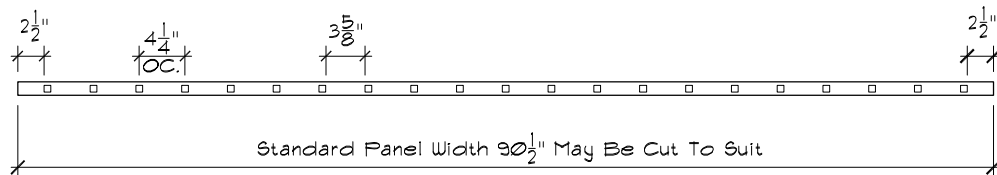
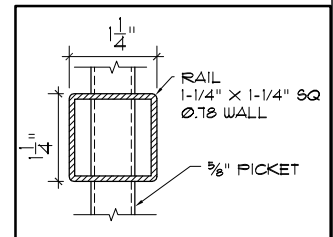

Specifications

<p>POST, RAILS & PICKETS: Cold Formed Steel Tubing Interior And Exterior Galvalume Coating Chromate Conversion Coating Electrostatically Applied Thermally Bonded Polyester Powder Coating Minimum Film Thickness 2.5 Mils</p> <p>POSTS: 2" x 2" (51mm x 51mm) 16 Gauge Standard Post Spacing 97-1/8" (2466mm) OC.</p> <p>POST CAP: Pyramid, Ball or Spear</p> <p>RAILS: 1-1/4" x 1-1/4" (32mm x 32mm) 14 Gauge</p> <p>PICKETS: 5/8" x 5/8" (15mm x 15mm) 16 Gauge</p>	<p>FITTINGS: 15 Gauge Stamp Forged Factory Finish. As Above</p> <p>WELDS: Stainless Steel</p> <p>STANDARD PANEL WIDTH: 91-1/2" (2324mm)</p> <p>AVAILABLE PANEL HEIGHTS: 48" (1219mm) (plus cap if applicable) 60" (1524mm) 72" (1828mm)</p> <p>NOTE: Tamper Proof Nut Available For Brackets</p> <p>COLOURS: Standard - High Gloss Black Optional Colours - Brown, Forest Green & Matt Black Custom Colours Available Upon Request.</p>
---	---

The following note shall apply to all drawings and associated documents:
 1. Copyright of this drawing and design is reserved by the Designer & European Wrought Iron Works Ltd. The drawing and all associated documents are an instrument of service by the Designer & European Wrought Iron Works Ltd. The drawing and the information contained therein may not be reproduced in whole or in part without prior written or verbal permission of the designer or European Wrought Iron Works Ltd.
 2. Drawings are not to be scaled for construction. All existing site conditions and dimensions required to perform the work are to be verified and any discrepancies are to be reported to the designer & European Wrought Iron Works Ltd.
 3. These drawings are not to be used for construction unless noted below as "Issued for Construction"
 4. All work to be carried out in conformance with the Code and Bylaws of the authorities having jurisdiction.
 5. The Designer of these plans and specifications gives no warranty or representation to any party about the constructability of the item represented by them.

CONFIDENTIAL: NOT TO BE DISCLOSED OR REPRODUCED

EUROPEAN
WROUGHT IRON WORKS

WITHOUT THE WRITTEN PERMISSION OF EUROPEAN WROUGHT IRON WORKS LTD.

TITLE:
Royalty Collection
Lord Custom with Dbl. Top Rail iv

TOLERANCES INCHES UNLESS OTHERWISE NOTED
 X.XXX" ±0.005"
 X.XX" ±0.05"
 X.X" ±0.25"
 FRACTIONAL ±1/16"
 ANGULAR ±1°

SCALE: NTS.
DATE DRAWN: June 2015
DRAWN BY: DCM

DO NOT MODIFY OR SCALE DRAWING

PROJECT TITLE:

DESIGN: P.D.
SHEET NO.: 5m

DRAWING & DESIGN REMAIN THE PROPERTY OF EUROPEAN WROUGHT IRON WORKS LTD.

FINISH: Custom
DRAWING NUMBER: RC-05m
REV: 1- A

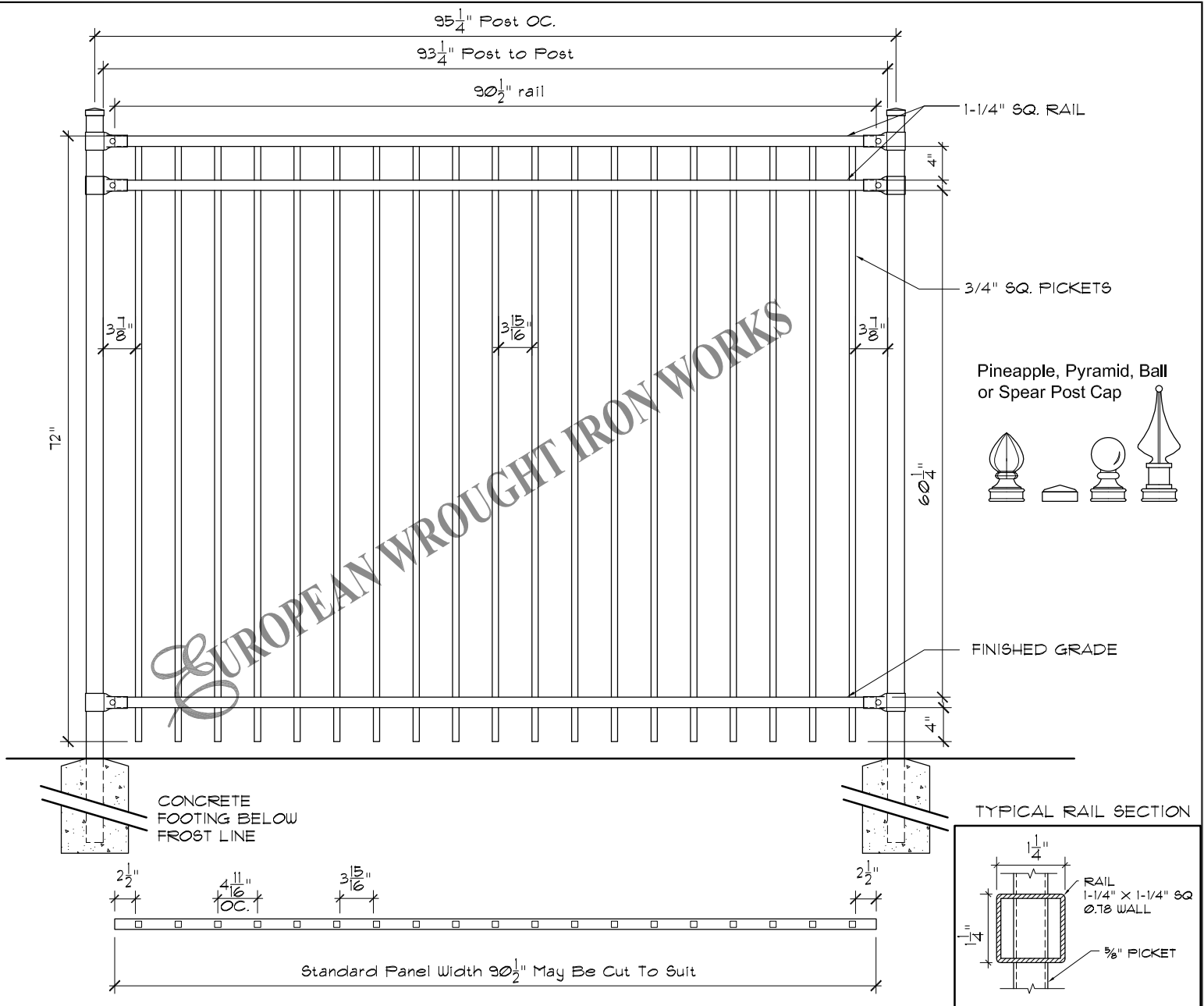

Specifications

POST, RAILS & PICKETS:	Cold Formed Steel Tubing Interior And Exterior Galvalume Coating Chromate Conversion Coating Electrostatically Applied Thermally Bonded Polyester Powder Coating Minimum Film Thickness 2.5 Mils	FITTINGS:	15 Gauge Stamp Forged Factory Finish. As Above
POSTS:	2" x 2" (51mm x 51mm) 16 Gauge Standard Post Spacing 97-1/8" (2466mm) OC.	WELDS:	Stainless Steel
POST CAP:	Pyramid, Ball or Spear	STANDARD PANEL WIDTH:	91-1/2" (2324mm)
RAILS:	1-1/4" x 1-1/4" (32mm x 32mm) 14 Gauge	AVAILABLE PANEL HEIGHTS:	48" (1219mm) (plus cap if applicable) 60" (1524mm) 72" (1828mm)
PICKETS:	3/4" x 3/4" (19mm x 19mm) 16 Gauge	NOTE:	Tamper Proof Nut Available For Brackets
		COLOURS:	Standard - High Gloss Black Optional Colours - Brown, Forest Green & Matt Black Custom Colours Available Upon Request.

The following note shall apply to all drawings and associated documents:
1. Copyright of this drawing and design is reserved by the Designer & European Wrought Iron Works Ltd. The drawing and all associated documents are an instrument of service by the Designer & European Wrought Iron Works Ltd. The drawing and the information contained therein may not be reproduced in whole or in part without prior written or verbal permission of the designer or European Wrought Iron Works Ltd.
2. Drawings are not to be scaled for construction. All existing site conditions and dimensions required to perform the work are to be verified and any discrepancies are to be reported to the designer & European Wrought Iron Works Ltd.
3. These drawings are not to be used for construction unless noted below as "Issued for Construction"
4. All work to be carried out in conformance with the Code and Bylaws of the authorities having jurisdiction.
5. The Designer of these plans and specifications gives no warranty or representation to any party about the constructability of the item represented by them.

CONFIDENTIAL: NOT TO BE DISCLOSED OR REPRODUCED

EUROPEAN WROUGHT IRON WORKS

WITHOUT THE WRITTEN PERMISSION OF EUROPEAN WROUGHT IRON WORKS LTD.

TITLE: **Royalty Collection**
Lord Custom with Dbl. Top Rail (3/4)

TOLERANCES INCHES UNLESS OTHERWISE NOTED
X.XXX" ±0.005"
X.XX" ±0.05"
X.X" ±0.25"
FRACTIONAL ±1/16"
ANGULAR ±1°

SCALE: NTS.

DATE DRAWN: Feb 2018

DRAWN BY: DCM

DO NOT MODIFY OR SCALE DRAWING

PROJECT TITLE:

DESIGN: P.D.

SHEET NO: 5n

DRAWING & DESIGN REMAIN THE PROPERTY OF EUROPEAN WROUGHT IRON WORKS LTD.

FINISH: Custom

DRAWING NUMBER: RC-05n

REV 1- A

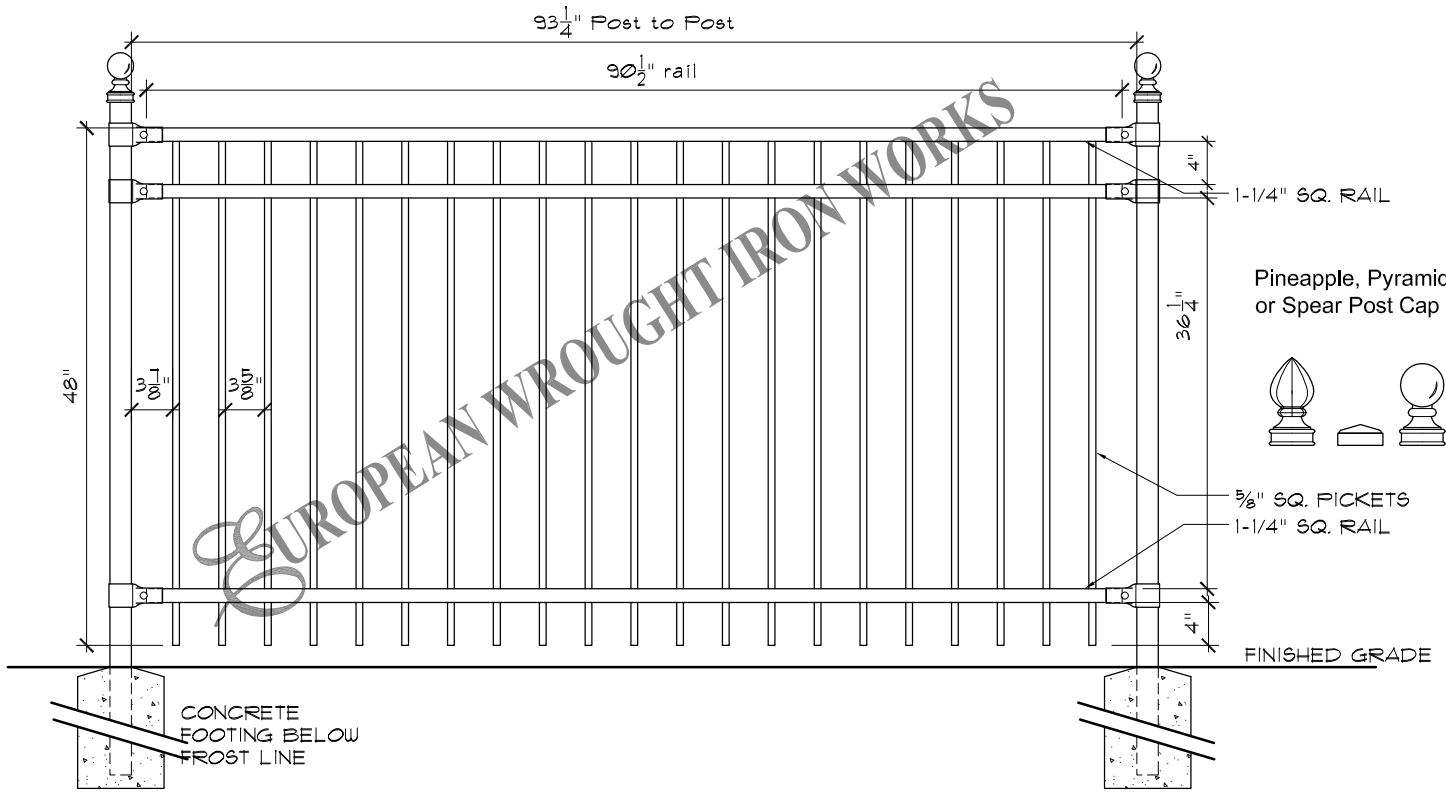

Pineapple, Pyramid, Ball or Spear Post Cap

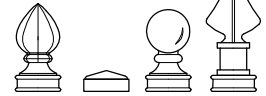

5/8" SQ. PICKETS
1-1/4" SQ. RAIL

FINISHED GRADE

CONCRETE FOOTING BELOW FROST LINE

TYPICAL RAIL SECTION

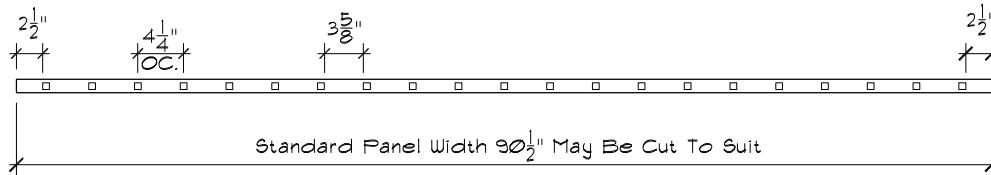
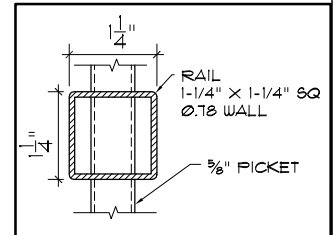

Specifications

POST, RAILS & PICKETS:	Cold Formed Steel Tubing Interior And Exterior Galvalume Coating Chromate Conversion Coating Electrostatically Applied Thermally Bonded Polyester Powder Coating Minimum Film Thickness 2.5 Mils	FITTINGS:	15 Gauge Stamp Forged Factory Finish. As Above
POSTS:	2" x 2" (51mm x 51mm) 16 Gauge Standard Post Spacing 97-1/8" (2466mm) OC.	WELDS:	Stainless Steel
POST CAP:	Pyramid, Ball or Spear	STANDARD PANEL WIDTH:	91-1/2" (2324mm)
RAILS:	1-1/4" x 1-1/4" (32mm x 32mm) 14 Gauge	AVAILABLE PANEL HEIGHTS:	48" (1219mm) (plus cap if applicable) 60" (1524mm) 72" (1828mm)
PICKETS:	5/8" x 5/8" (15mm x 15mm) 16 Gauge	NOTE:	Tamper Proof Nut Available For Brackets
		COLOURS:	Standard - High Gloss Black Optional Colours - Brown, Forest Green & Matt Black Custom Colours Available Upon Request.

The following note shall apply to all drawings and associated documents:
1. Copyright of this drawing and design is reserved by the Designer & European Wrought Iron Works Ltd. The drawing and all associated documents are an instrument of service by the Designer & European Wrought Iron Works Ltd. The drawing and the information contained therein may not be reproduced in whole or in part without prior written or verbal permission of the designer or European Wrought Iron Works Ltd.
2. Drawings are not to be scaled for construction. All existing site conditions and dimensions required to perform the work are to be verified and any discrepancies are to be reported to the designer & European Wrought Iron Works Ltd.
3. These drawings are not to be used for construction unless noted below as "Issued for Construction"
4. All work to be carried out in conformance with the Code and Bylaws of the authorities having jurisdiction.
5. The Designer of these plans and specifications gives no warranty or representation to any party about the constructability of the item represented by them.

CONFIDENTIAL: NOT TO BE DISCLOSED OR REPRODUCED



TITLE: **Royalty Collection**
Lord Custom with Dbl. Top Rail

TOLERANCES INCHES UNLESS OTHERWISE NOTED
X.XXX" ±0.005"
X.XX" ±0.05"
X.X" ±0.25"
FRACTIONAL ±1/16"
ANGULAR ±1°

SCALE: NTS.
DATE DRAWN: Feb 2018
DRAWN BY: DCM

DO NOT MODIFY OR SCALE DRAWING

PROJECT TITLE:
DESIGN: P.D.
SHEET NO: 5p

DRAWING & DESIGN REMAIN THE PROPERTY OF EUROPEAN WROUGHT IRON WORKS LTD.

FINISH: Custom
DRAWING NUMBER: RC-05p

REV 1- A

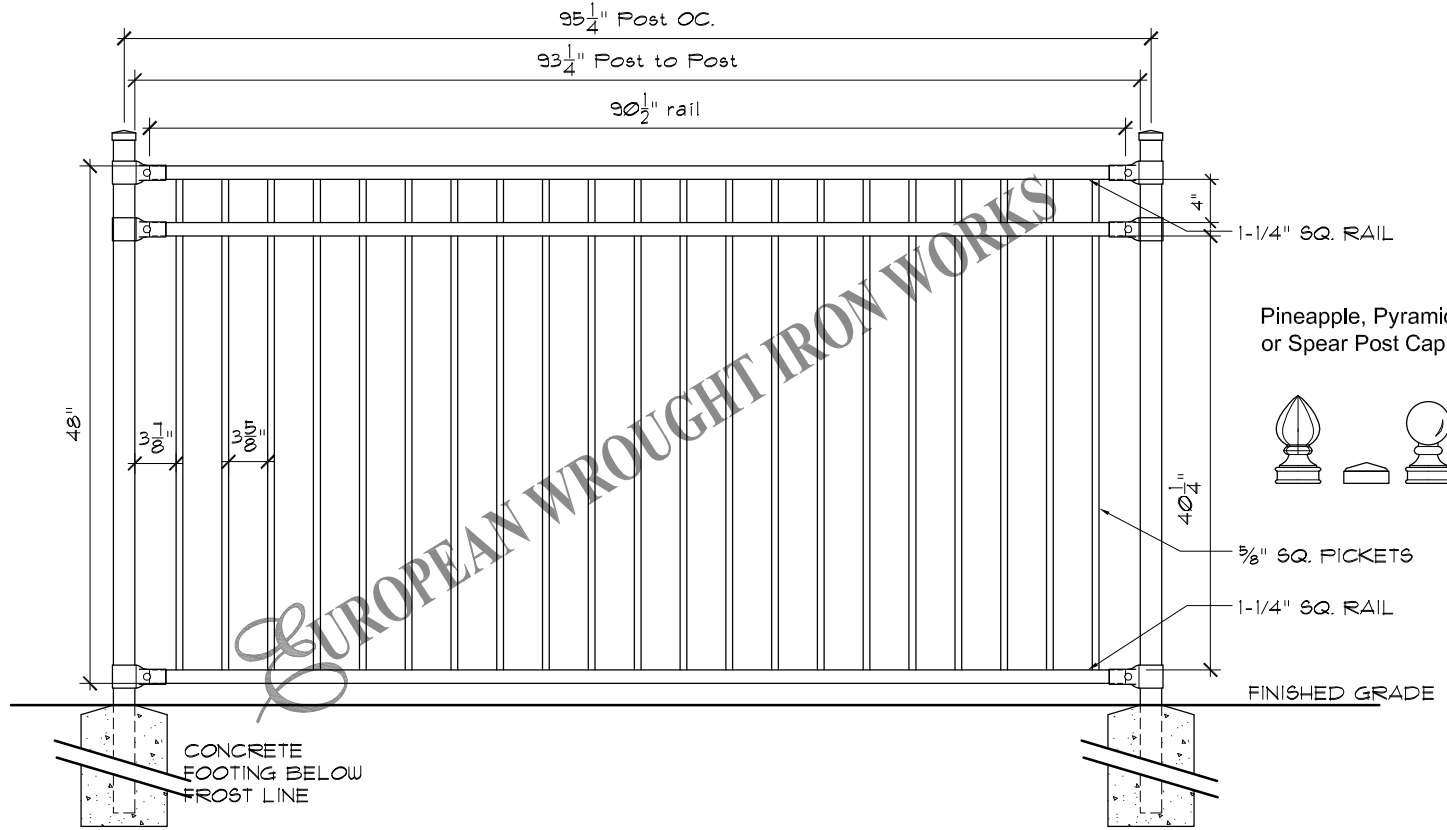

Pineapple, Pyramid, Ball or Spear Post Cap

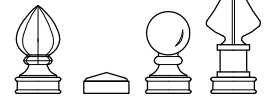

TYPICAL RAIL SECTION

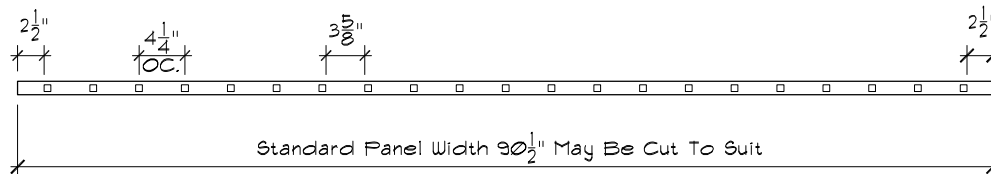
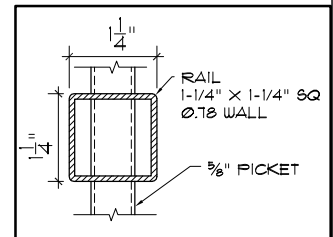

Specifications

POST, RAILS & PICKETS:	Cold Formed Steel Tubing Interior And Exterior Galvalume Coating Chromate Conversion Coating Electrostatically Applied Thermally Bonded Polyester Powder Coating Minimum Film Thickness 2.5 Mils	FITTINGS:	15 Gauge Stamp Forged Factory Finish. As Above
POSTS:	2" x 2" (51mm x 51mm) 16 Gauge Standard Post Spacing 97-1/8" (2466mm) OC.	WELDS:	Stainless Steel
POST CAP:	Pyramid, Ball or Spear	STANDARD PANEL WIDTH:	91-1/2" (2324mm)
RAILS:	1-1/4" x 1-1/4" (32mm x 32mm) 14 Gauge	AVAILABLE PANEL HEIGHTS:	48" (1219mm) (plus cap if applicable) 60" (1524mm) 72" (1828mm)
PICKETS:	5/8" x 5/8" (15mm x 15mm) 16 Gauge	NOTE:	Tamper Proof Nut Available For Brackets
		COLOURS:	Standard - High Gloss Black Optional Colours - Brown, Forest Green & Matt Black Custom Colours Available Upon Request.

The following note shall apply to all drawings and associated documents:

- Copyright of this drawing and design is reserved by the Designer & European Wrought Iron Works Ltd. The drawing and all associated documents are an instrument of service by the Designer & European Wrought Iron Works Ltd. The drawing and the information contained therein may not be reproduced in whole or in part without prior written or verbal permission of the designer or European Wrought Iron Works Ltd.
- Drawings are not to be scaled for construction. All existing site conditions and dimensions required to perform the work are to be verified and any discrepancies are to be reported to the designer & European Wrought Iron Works Ltd.
- These drawings are not to be used for construction unless noted below as "Issued for Construction"
- All work to be carried out in conformance with the Code and Bylaws of the authorities having jurisdiction.
- The Designer of these plans and specifications gives no warranty or representation to any party about the constructability of the item represented by them.

CONFIDENTIAL: NOT TO BE DISCLOSED OR REPRODUCED



TITLE: **Royalty Collection**
Lord Custom with Dbl. Top Rail

TOLERANCES INCHES
UNLESS OTHERWISE NOTED
".X,XXX" ±0.005"
".X,XX" ±0.05"
".X.X" ±0.25"
FRACTIONAL ±1/16"
ANGULAR ±1°

SCALE: NTS.
DATE DRAWN: Feb 2018
DRAWN BY: DCM

DO NOT MODIFY OR SCALE DRAWING

PROJECT TITLE:

DRAWING & DESIGN REMAIN THE PROPERTY OF EUROPEAN WROUGHT IRON WORKS LTD.

DESIGN: P.D.
SHEET NO: 5q

FINISH: Custom
DRAWING NUMBER: RC-05q

REV 1- A

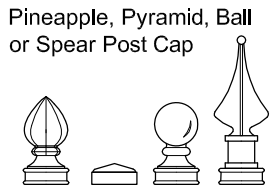
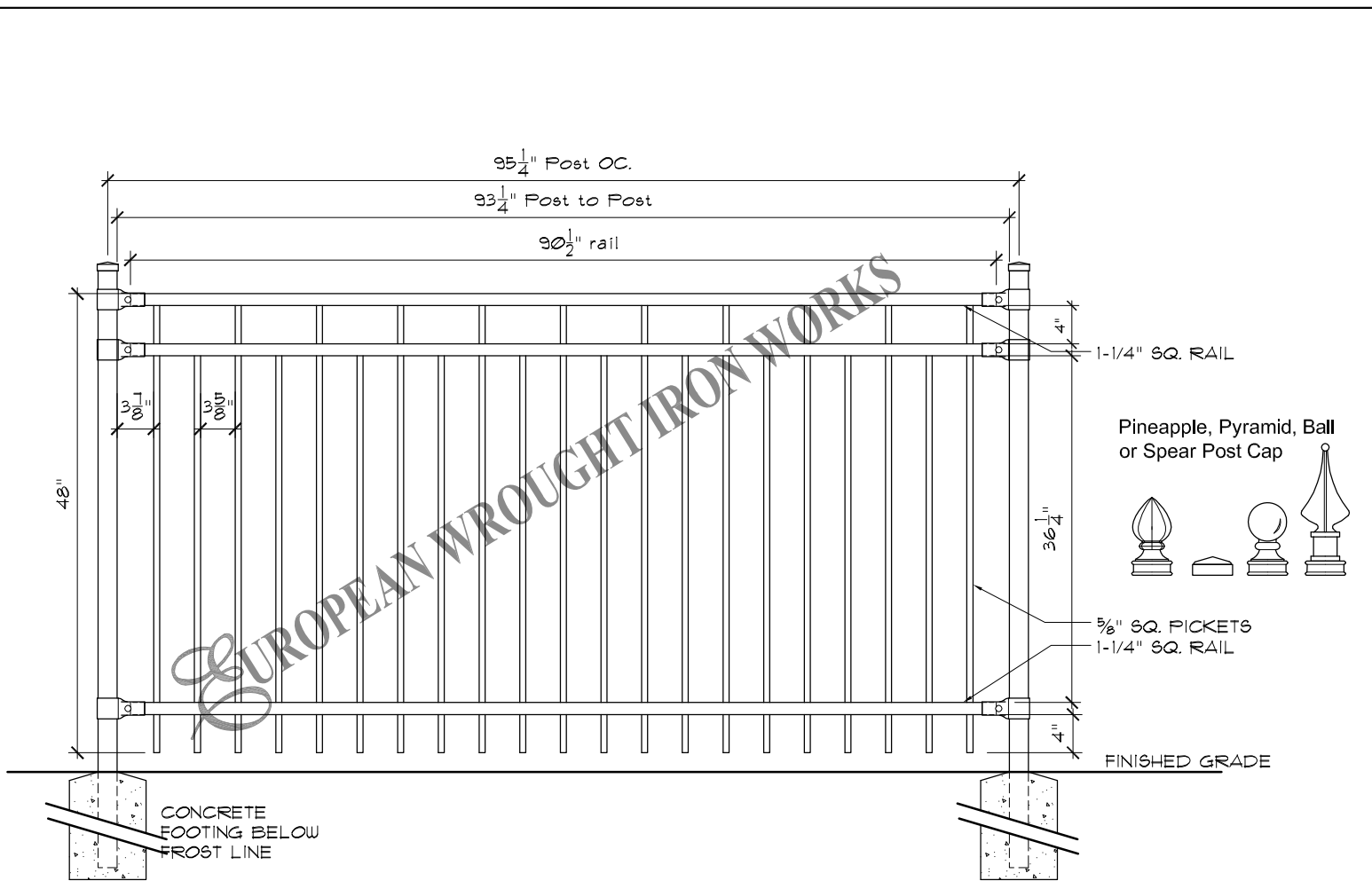

5/8" SQ. PICKETS
1-1/4" SQ. RAIL

FINISHED GRADE

EUROPEAN WROUGHT IRON WORKS

TYPICAL RAIL SECTION

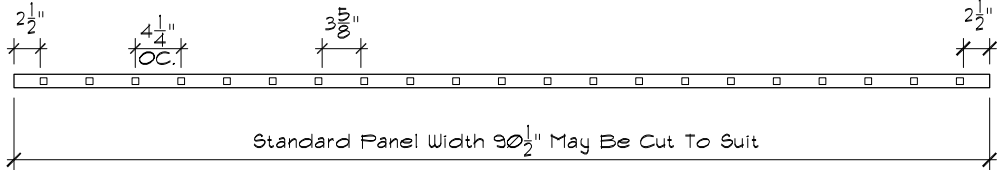
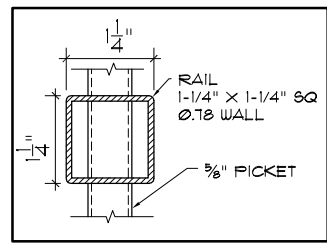

Specifications

<p>POST, RAILS & PICKETS: Cold Formed Steel Tubing Interior And Exterior Galvalume Coating Chromate Conversion Coating Electrostatically Applied Thermally Bonded Polyester Powder Coating Minimum Film Thickness 2.5 Mils</p> <p>POSTS: 2" x 2" (51mm x 51mm) 16 Gauge Standard Post Spacing 97-1/8" (2466mm) OC.</p> <p>POST CAP: Pyramid, Ball or Spear</p> <p>RAILS: 1-1/4" x 1-1/4" (32mm x 32mm) 14 Gauge</p> <p>PICKETS: 5/8" x 5/8" (15mm x 15mm) 16 Gauge</p>	<p>FITTINGS: 15 Gauge Stamp Forged Factory Finish. As Above</p> <p>WELDS: Stainless Steel</p> <p>STANDARD PANEL WIDTH: 91-1/2" (2324mm)</p> <p>AVAILABLE PANEL HEIGHTS: 48" (1219mm) (plus cap if applicable) 60" (1524mm) 72" (1828mm)</p> <p>NOTE: Tamper Proof Nut Available For Brackets</p> <p>COLOURS: Standard - High Gloss Black Optional Colours - Brown, Forest Green & Matt Black Custom Colours Available Upon Request.</p>
---	---

<p>The following note shall apply to all drawings and associated documents: 1. Copyright of this drawing and design is reserved by the Designer & European Wrought Iron Works Ltd. The drawing and all associated documents are an instrument of service by the Designer & European Wrought Iron Works Ltd. The drawing and the information contained therein may not be reproduced in whole or in part without prior written or verbal permission of the designer or European Wrought Iron Works Ltd. 2. Drawings are not to be scaled for construction. All existing site conditions and dimensions required to perform the work are to be verified and any discrepancies are to be reported to the designer & European Wrought Iron Works Ltd. 3. These drawings are not to be used for construction unless noted below as "Issued for Construction" 4. All work to be carried out in conformance with the Code and Bylaws of the authorities having jurisdiction. 5. The Designer of these plans and specifications gives no warranty or representation to any party about the constructability of the item represented by them.</p>	<p style="font-size: 8px;">CONFIDENTIAL: NOT TO BE DISCLOSED OR REPRODUCED</p> <p style="font-size: 8px;">WITHOUT THE WRITTEN PERMISSION OF EUROPEAN WROUGHT IRON WORKS LTD.</p>	<p>TOLERANCES INCHES UNLESS OTHERWISE NOTED X.XXX" ±0.005" X.XX" ±0.05" X.X" ±0.25" FRACTIONAL ±1/16" ANGULAR ±1°</p>	<p>DO NOT MODIFY OR SCALE DRAWING</p> <p>PROJECT TITLE:</p>	<p>DRAWING & DESIGN REMAIN THE PROPERTY OF EUROPEAN WROUGHT IRON WORKS LTD.</p>	
<p>TITLE: Royalty Collection <i>Lord Custom with Dbl. Top Rail</i></p>	<p>SCALE: NTS.</p> <p>DATE DRAWN: Feb 2018</p> <p>DRAWN BY: DCM</p>	<p>DESIGN: P.D.</p> <p>SHEET NO: 5r</p>	<p>FINISH: Custom</p> <p>DRAWING NUMBER: RC-05r</p>	<p>REV 1-</p>	<p>A</p>

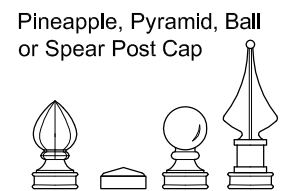
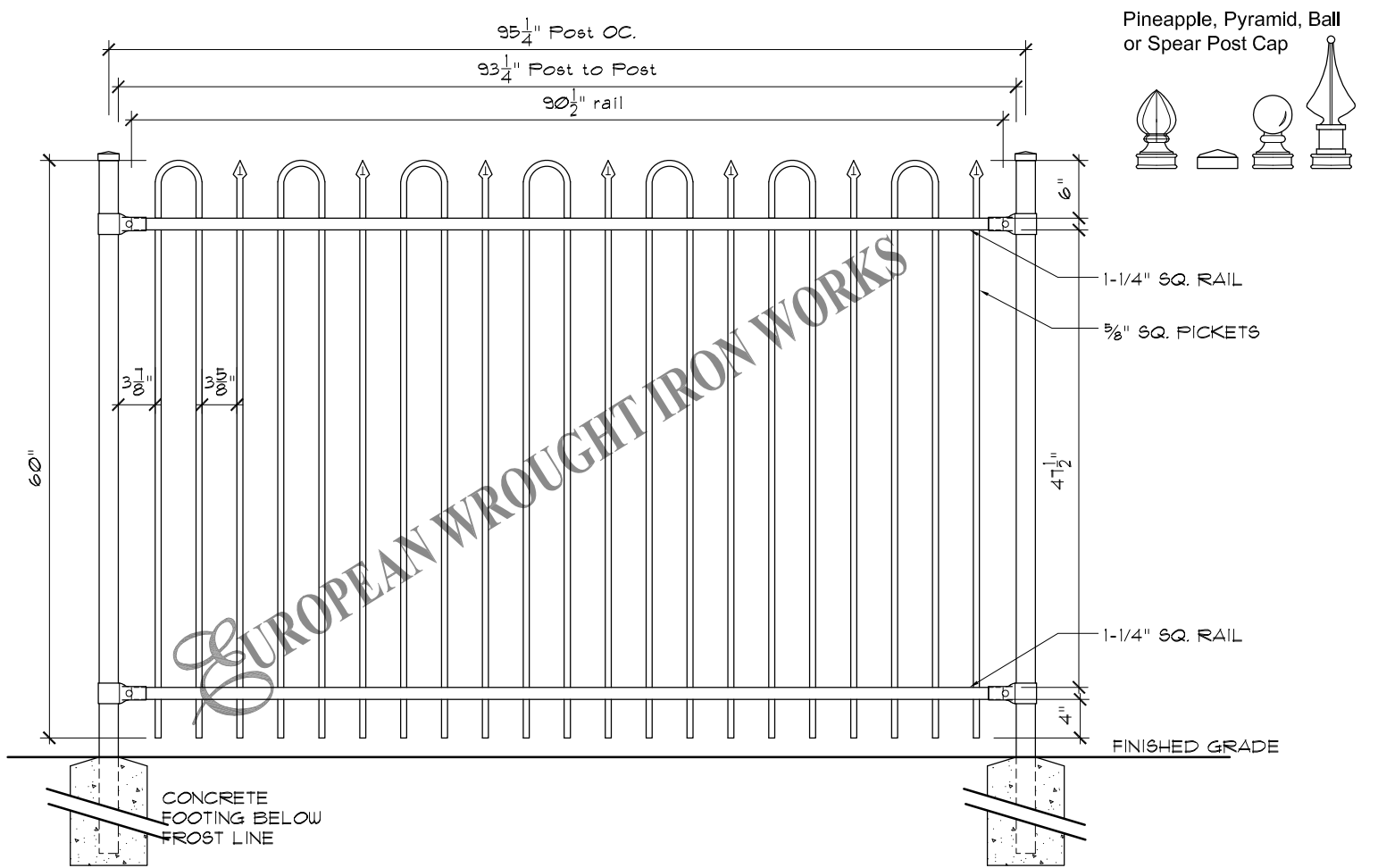

EUROPEAN WROUGHT IRON WORKS

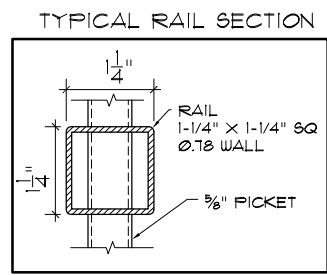
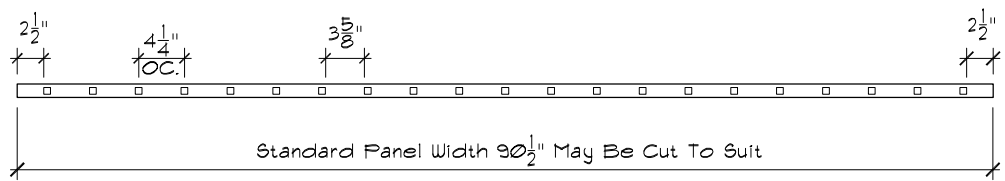

Specifications

<p>POST, RAILS & PICKETS: Cold Formed Steel Tubing Interior And Exterior Galvalume Coating Chromate Conversion Coating Electrostatically Applied Thermally Bonded Polyester Powder Coating Minimum Film Thickness 2.5 Mils</p> <p>POSTS: 2" x 2" (51mm x 51mm) 16 Gauge Standard Post Spacing 97-1/8" (2466mm) OC.</p> <p>POST CAP: Pyramid, Ball or Spear</p> <p>RAILS: 1-1/4" x 1-1/4" (32mm x 32mm) 14 Gauge</p> <p>PICKETS: 5/8" x 5/8" (15mm x 15mm) 16 Gauge</p>	<p>FITTINGS: 15 Gauge Stamp Forged Factory Finish. As Above</p> <p>WELDS: Stainless Steel</p> <p>STANDARD PANEL WIDTH: 91-1/2" (2324mm)</p> <p>AVAILABLE PANEL HEIGHTS: 48" (1219mm) (plus cap if applicable) 60" (1524mm) 72" (1828mm)</p> <p>NOTE: Tamper Proof Nut Available For Brackets</p> <p>COLOURS: Standard - High Gloss Black Optional Colours - Brown, Forest Green & Matt Black Custom Colours Available Upon Request.</p>
---	---

<p>The following note shall apply to all drawings and associated documents:</p> <p>1. Copyright of this drawing and design is reserved by the Designer & European Wrought Iron Works Ltd. The drawing and all associated documents are an instrument of service by the Designer & European Wrought Iron Works Ltd. The drawing and the information contained therein may not be reproduced in whole or in part without prior written or verbal permission of the designer or European Wrought Iron Works Ltd.</p> <p>2. Drawings are not to be scaled for construction. All existing site conditions and dimensions required to perform the work are to be verified and any discrepancies are to be reported to the designer & European Wrought Iron Works Ltd.</p> <p>3. These drawings are not to be used for construction unless noted below as "Issued for Construction"</p> <p>4. All work to be carried out in conformance with the Code and Bylaws of the authorities having jurisdiction.</p> <p>5. The Designer of these plans and specifications gives no warranty or representation to any party about the constructability of the item represented by them.</p>	<p>CONFIDENTIAL: NOT TO BE DISCLOSED OR REPRODUCED</p> <p>WITHOUT THE WRITTEN PERMISSION OF EUROPEAN WROUGHT IRON WORKS LTD.</p>	<p>TOLERANCES INCHES UNLESS OTHERWISE NOTED X.XXX" ±0.005" X.XX" ±0.05" X.X" ±0.25" FRACTIONAL ±1/16" ANGULAR ±1°</p>	<p>DO NOT MODIFY OR SCALE DRAWING</p> <p>DRAWING & DESIGN REMAIN THE PROPERTY OF EUROPEAN WROUGHT IRON WORKS LTD.</p>	<p>PROJECT TITLE:</p>	
	<p>TITLE: Royalty Collection Windsor</p>	<p>SCALE: NTS.</p> <p>DATE DRAWN: June 2015</p> <p>DRAWN BY: DCM</p>	<p>DESIGN: P.D.</p> <p>SHEET NO: 7</p>	<p>FINISH: Custom</p> <p>DRAWING NUMBER: RC-07</p>	<p>REV: 1-</p> <p>A</p>

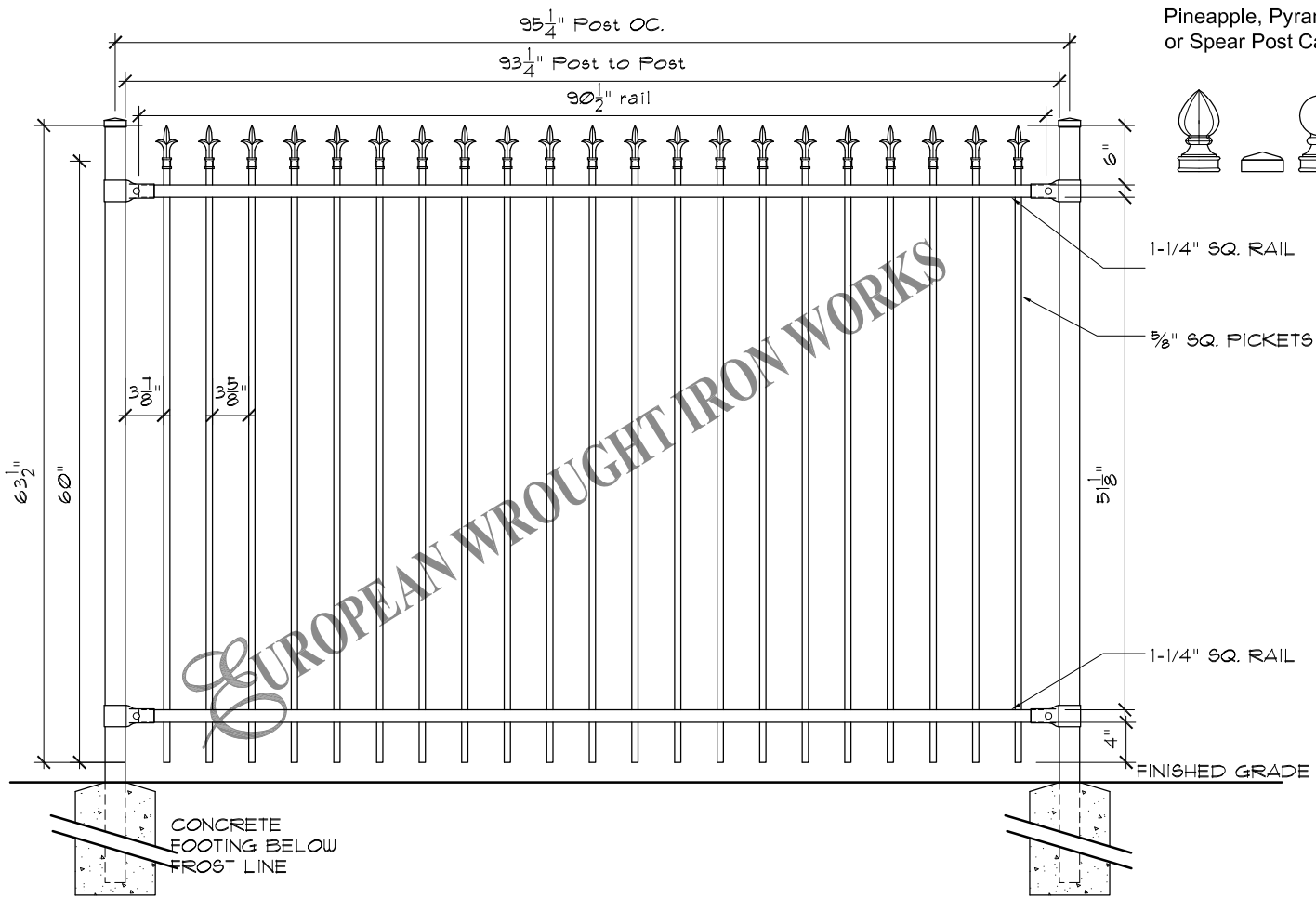

Pineapple, Pyramid, Ball or Spear Post Cap

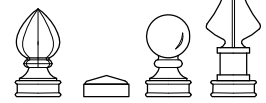

EUROPEAN WROUGHT IRON WORKS

1-1/4" SQ. RAIL

5/8" SQ. PICKETS

1-1/4" SQ. RAIL

FINISHED GRADE

CONCRETE FOOTING BELOW FROST LINE

TYPICAL RAIL SECTION

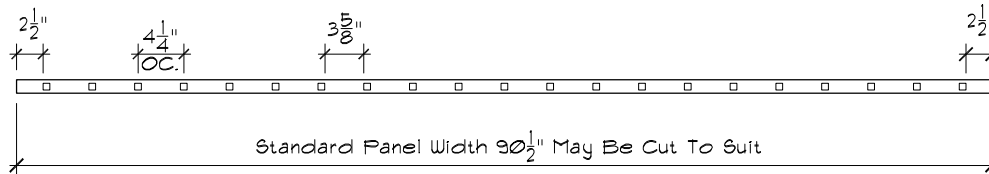
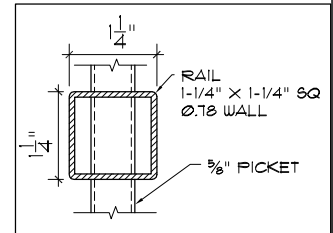

Specifications

POST, RAILS & PICKETS: Cold Formed Steel Tubing
Interior And Exterior Galvalume Coating
Chromate Conversion Coating
Electrostatically Applied
Thermally Bonded Polyester Powder Coating
Minimum Film Thickness 2.5 Mils

POSTS: 2" x 2" (51mm x 51mm) 16 Gauge
Standard Post Spacing 97-1/8" (2466mm) OC.

POST CAP: Pyramid, Ball or Spear

RAILS: 1-1/4" x 1-1/4" (32mm x 32mm) 14 Gauge

PICKETS: 5/8" x 5/8" (15mm x 15mm) 16 Gauge

FITTINGS: 15 Gauge Stamp Forged Factory Finish. As Above

WELDS: Stainless Steel

STANDARD PANEL WIDTH: 91-1/2" (2324m)

AVAILABLE PANEL HEIGHTS: 48" (1219mm)
(plus cap if applicable)
60" (1524mm)
72" (1828mm)

NOTE: Tamper Proof Nut Available For Brackets

COLOURS: Standard - High Gloss Black
Optional Colours - Brown, Forest Green & Matt Black
Custom Colours Available Upon Request.

Information subject to change without notice

The following note shall apply to all drawings and associated documents:
1. Copyright of this drawing and design is reserved by the Designer & European Wrought Iron Works Ltd. The drawing and all associated documents are an instrument of service by the Designer & European Wrought Iron Works Ltd. The drawing and the information contained therein may not be reproduced in whole or in part without prior written or verbal permission of the designer or European Wrought Iron Works Ltd.
2. Drawings are not to be scaled for construction. All existing site conditions and dimensions required to perform the work are to be verified and any discrepancies are to be reported to the designer & European Wrought Iron Works Ltd.
3. These drawings are not to be used for construction unless noted below as "Issued for Construction"
4. All work to be carried out in conformance with the Code and Bylaws of the authorities having jurisdiction.
5. The Designer of these plans and specifications gives no warranty or representation to any party about the constructability of the item represented by them.

CONFIDENTIAL: NOT TO BE DISCLOSED OR REPRODUCED



ROYALTY COLLECTION
Emperor

TITLE: **Royalty Collection Emperor**

TOLERANCES INCHES UNLESS OTHERWISE NOTED
X.XXX" ±0.005"
X.XX" ±0.05"
X.X" ±0.25"
FRACTIONAL ±1/16"
ANGULAR ±1°

SCALE: NTS.

DATE DRAWN: June 2015

DRAWN BY: DCM

DO NOT MODIFY OR SCALE DRAWING

PROJECT TITLE:

DESIGN: P.D.

SHEET NO: 8

DRAWING & DESIGN REMAIN THE PROPERTY OF EUROPEAN WROUGHT IRON WORKS LTD.

FINISH: Custom

DRAWING NUMBER: RC-08

REV 1- A

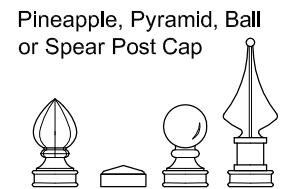
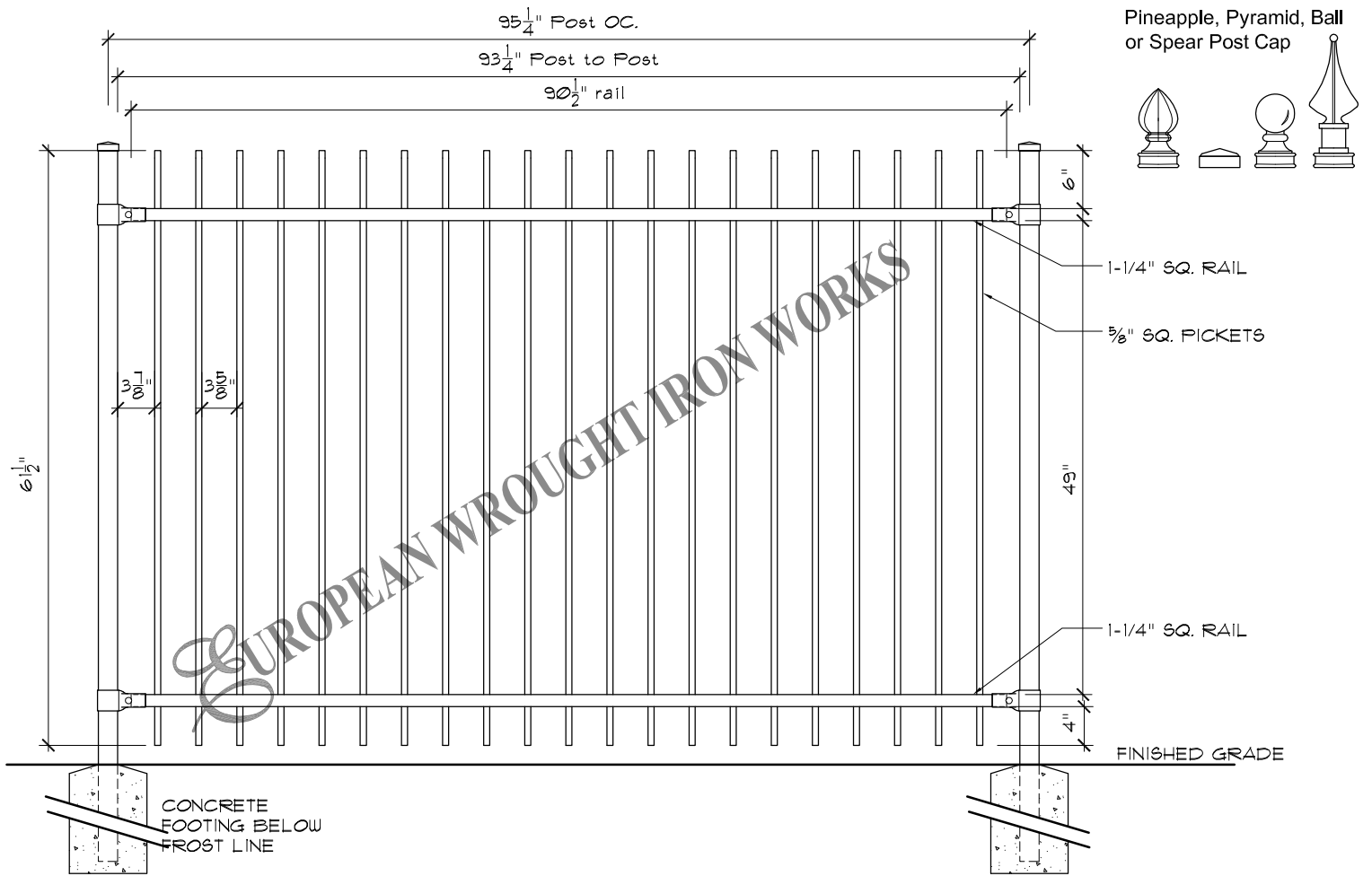

1-1/4" SQ. RAIL
5/8" SQ. PICKETS

1-1/4" SQ. RAIL

FINISHED GRADE

CONCRETE FOOTING BELOW FROST LINE

TYPICAL RAIL SECTION

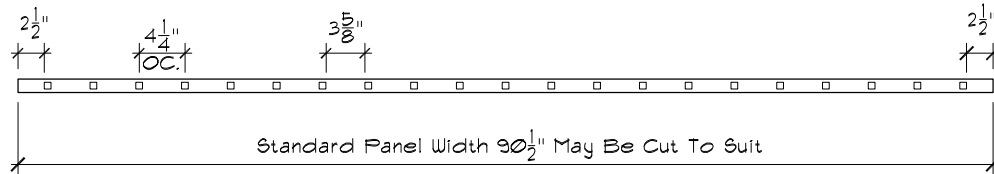
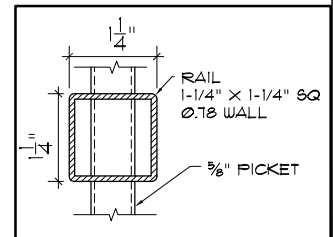

Specifications

POST, RAILS & PICKETS: Cold Formed Steel Tubing
Interior And Exterior Galvalume Coating
Chromate Conversion Coating
Electrostatically Applied
Thermally Bonded Polyester Powder Coating
Minimum Film Thickness 2.5 Mills

POSTS: 2" x 2" (51mm x 51mm) 16 Gauge
Standard Post Spacing 97-1/8" (2466mm) OC.

POST CAP: Pyramid, Ball or Spear

RAILS: 1-1/4" x 1-1/4" (32mm x 32mm) 14 Gauge

PICKETS: 5/8" x 5/8" (15mm x 15mm) 16 Gauge

FITTINGS: 15 Gauge Stamp Forged Factory Finish. As Above

WELDS: Stainless Steel

STANDARD PANEL WIDTH: 91-1/2" (2324m)

AVAILABLE PANEL HEIGHTS: 48" (1219mm)
(plus cap if applicable) 60" (1524mm)
72" (1828mm)

NOTE: Tamper Proof Nut Available For Brackets

COLOURS: Standard - High Gloss Black
Optional Colours - Brown, Forest Green & Matt Black
Custom Colours Available Upon Request.

The following note shall apply to all drawings and associated documents:

- Copyright of this drawing and design is reserved by the Designer & European Wrought Iron Works Ltd. The drawing and all associated documents are an instrument of service by the Designer & European Wrought Iron Works Ltd. The drawing and the information contained therein may not be reproduced in whole or in part without prior written or verbal permission of the designer or European Wrought Iron Works Ltd.
- Drawings are not to be scaled for construction. All existing site conditions and dimensions required to perform the work are to be verified and any discrepancies are to be reported to the designer & European Wrought Iron Works Ltd.
- These drawings are not to be used for construction unless noted below as "Issued for Construction"
- All work to be carried out in conformance with the Code and Bylaws of the authorities having jurisdiction.
- The Designer of these plans and specifications gives no warranty or representation to any party about the constructability of the item represented by them.

CONFIDENTIAL: NOT TO BE DISCLOSED OR REPRODUCED



TITLE: **Royalty Collection
Tudor**

TOLERANCES INCHES UNLESS OTHERWISE NOTED
X.XXX" ±0.005"
X.XX" ±0.05"
X.X" ±0.25"
FRACTIONAL ±1/16"
ANGULAR ±1°

SCALE: NTS.
DATE DRAWN: June 2015
DRAWN BY: DCM

DO NOT MODIFY OR SCALE DRAWING

PROJECT TITLE:

DESIGN: P.D.
SHEET NO: 2

DRAWING & DESIGN REMAIN THE PROPERTY OF EUROPEAN WROUGHT IRON WORKS LTD.

FINISH: Custom
DRAWING NUMBER: RC-02

REV 1- A

Pineapple, Pyramid, Ball or Spear Post Cap

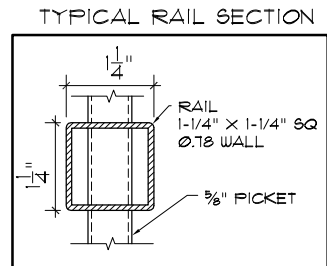
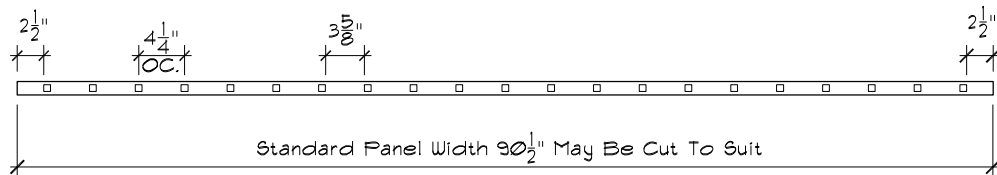
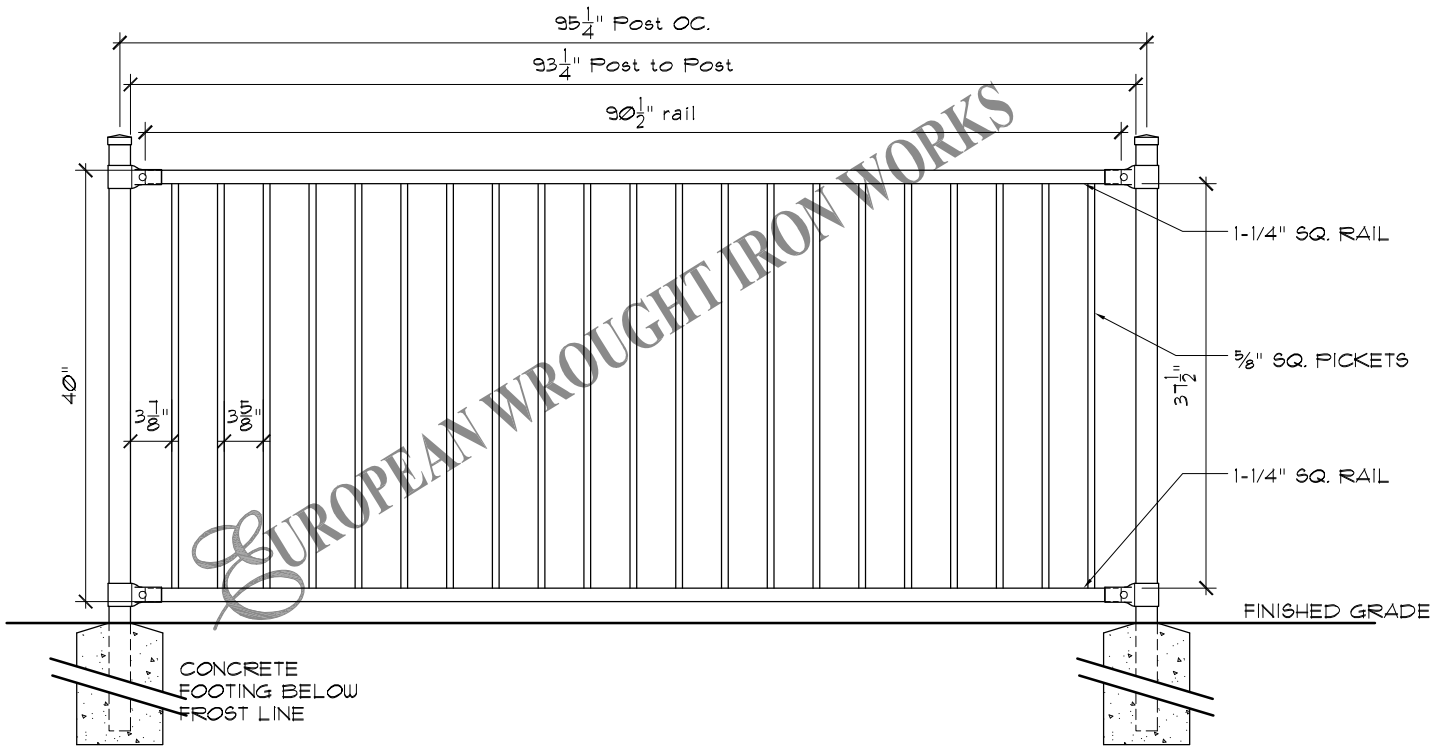
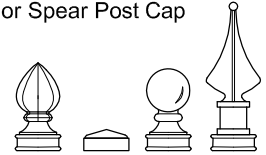

Specifications

POST, RAILS & PICKETS: Cold Formed Steel Tubing
Interior And Exterior Galvalume Coating
Chromate Conversion Coating
Electrostatically Applied
Thermally Bonded Polyester Powder Coating
Minimum Film Thickness 2.5 Mils

POSTS: 2" x 2" (51mm x 51mm) 16 Gauge
Standard Post Spacing 97-1/8" (2466mm) OC.

POST CAP: Pyramid, Ball or Spear

RAILS: 1-1/4" x 1-1/4" (32mm x 32mm) 14 Gauge

PICKETS: 5/8" x 5/8" (15mm x 15mm) 16 Gauge

FITTINGS: 15 Gauge Stamp Forged Factory Finish. As Above

WELDS: Stainless Steel

STANDARD PANEL WIDTH: 91-1/2" (2324mm)

AVAILABLE PANEL HEIGHTS: 48" (1219mm)
(plus cap if applicable) 60" (1524mm)
72" (1828mm)

NOTE: Tamper Proof Nut Available For Brackets

COLOURS: Standard - High Gloss Black
Optional Colours - Brown, Forest Green & Matt Black
Custom Colours Available Upon Request.

The following note shall apply to all drawings and associated documents:
1. Copyright of this drawing and design is reserved by the Designer & European Wrought Iron Works Ltd. The drawing and all associated documents are an instrument of service by the Designer & European Wrought Iron Works Ltd. The drawing and the information contained therein may not be reproduced in whole or in part without prior written or verbal permission of the designer or European Wrought Iron Works Ltd.
2. Drawings are not to be scaled for construction. All existing site conditions and dimensions required to perform the work are to be verified and any discrepancies are to be reported to the designer & European Wrought Iron Works Ltd.
3. These drawings are not to be used for construction unless noted below as "Issued for Construction"
4. All work to be carried out in conformance with the Code and Bylaws of the authorities having jurisdiction.
5. The Designer of these plans and specifications gives no warranty or representation to any party about the constructability of the item represented by them.

CONFIDENTIAL: NOT TO BE DISCLOSED OR REPRODUCED

Royalty Collection
Lord

TOLERANCES INCHES UNLESS OTHERWISE NOTED
X.XXX" ±0.005"
X.XX" ±0.05"
X.X" ±0.25"
FRACTIONAL ±1/16"
ANGULAR ±1°

SCALE: NTS.

DATE DRAWN: June 2015

DRAWN BY: DCM

DO NOT MODIFY OR SCALE DRAWING

PROJECT TITLE:

DESIGN: P.D.

SHEET NO: 5

DRAWING & DESIGN REMAIN THE PROPERTY OF EUROPEAN WROUGHT IRON WORKS LTD.

FINISH: Custom

DRAWING NUMBER: RC-05

REV 1- **A**

Pineapple, Pyramid, Ball or Spear Post Cap

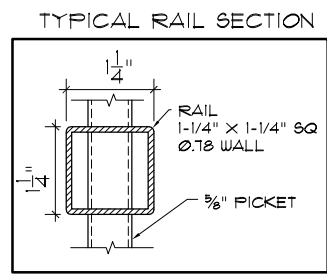
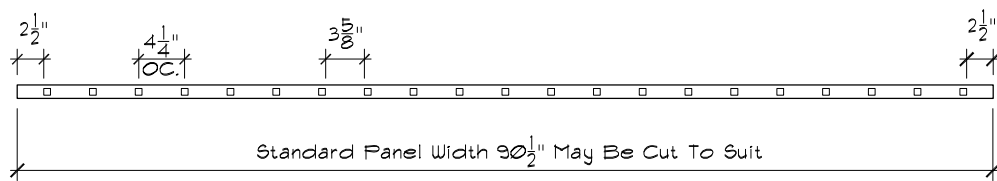
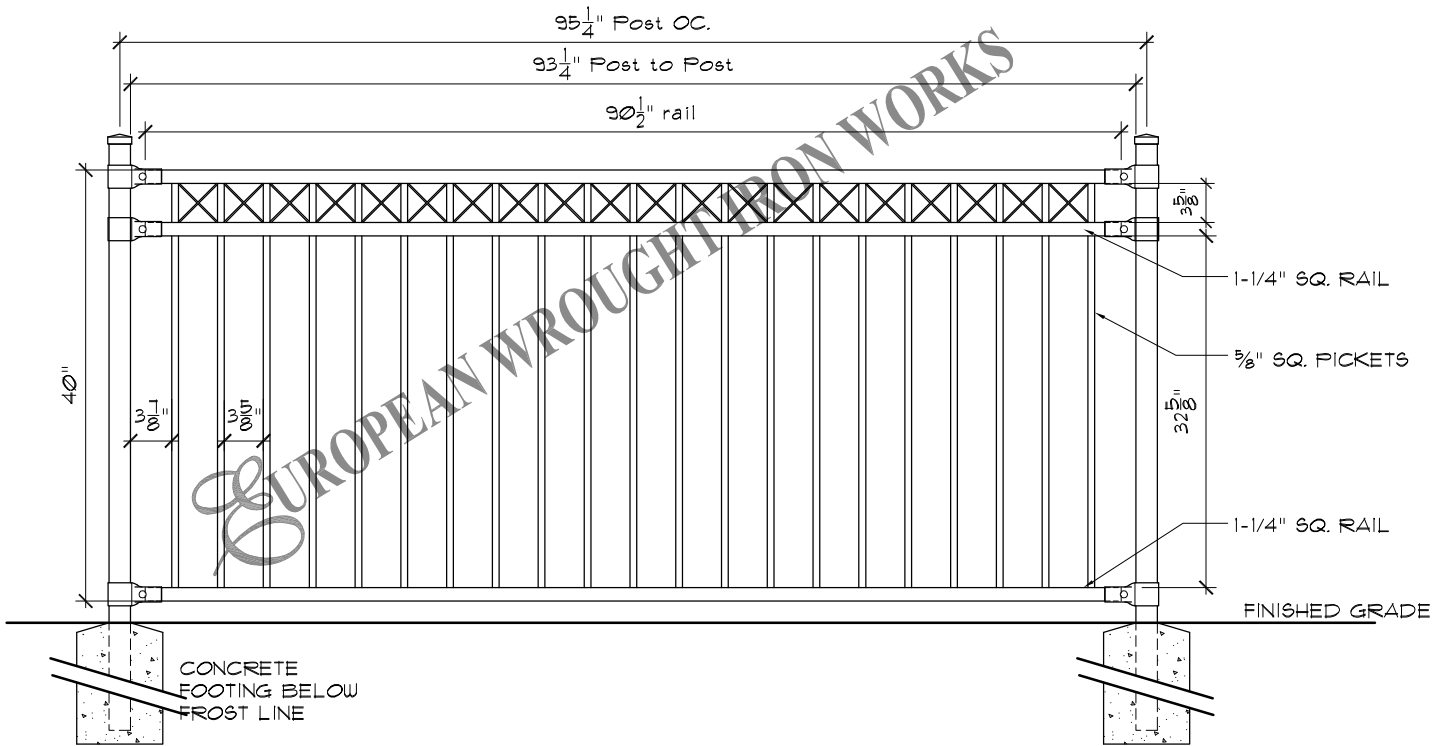
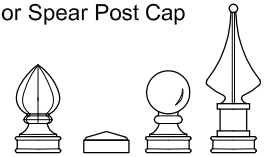

Specifications

POST, RAILS & PICKETS: Cold Formed Steel Tubing
Interior And Exterior Galvalume Coating
Chromate Conversion Coating
Electrostatically Applied
Thermally Bonded Polyester Powder Coating
Minimum Film Thickness 2.5 Mils

POSTS: 2" x 2" (51mm x 51mm) 16 Gauge
Standard Post Spacing 97-1/8" (2466mm) OC.

POST CAP: Pyramid, Ball or Spear

RAILS: 1-1/4" x 1-1/4" (32mm x 32mm) 14 Gauge

PICKETS: 5/8" x 5/8" (15mm x 15mm) 16 Gauge

FITTINGS: 15 Gauge Stamp Forged Factory Finish. As Above

WELDS: Stainless Steel

STANDARD PANEL WIDTH: 91-1/2" (2324mm)

AVAILABLE PANEL HEIGHTS: 48" (1219mm)
(plus cap if applicable) 60" (1524mm)
72" (1828mm)

NOTE: Tamper Proof Nut Available For Brackets

COLOURS: Standard - High Gloss Black
Optional Colours - Brown, Forest Green & Matt Black
Custom Colours Available Upon Request.

The following note shall apply to all drawings and associated documents:
1. Copyright of this drawing and design is reserved by the Designer & European Wrought Iron Works Ltd. The drawing and all associated documents are an instrument of service by the Designer & European Wrought Iron Works Ltd. The drawing and the information contained therein may not be reproduced in whole or in part without prior written or verbal permission of the designer or European Wrought Iron Works Ltd.
2. Drawings are not to be scaled for construction. All existing site conditions and dimensions required to perform the work are to be verified and any discrepancies are to be reported to the designer & European Wrought Iron Works Ltd.
3. These drawings are not to be used for construction unless noted below as "Issued for Construction"
4. All work to be carried out in conformance with the Code and Bylaws of the authorities having jurisdiction.
5. The Designer of these plans and specifications gives no warranty or representation to any party about the constructability of the item represented by them.

CONFIDENTIAL: NOT TO BE DISCLOSED OR REPRODUCED

WITHOUT THE WRITTEN PERMISSION OF EUROPEAN WROUGHT IRON WORKS LTD.

TITLE:
Royalty Collection
Lord Custom with Cross

TOLERANCES INCHES UNLESS OTHERWISE NOTED
X.XXX" ±0.005"
X.XX" ±0.05"
X.X" ±0.25"
FRACTIONAL ±1/16"
ANGULAR ±1°

SCALE: NTS.

DATE DRAWN: June 2015

DRAWN BY: DCM

DO NOT MODIFY OR SCALE DRAWING

PROJECT TITLE:

DESIGN: P.D.

SHEET NO: 5a

DRAWING & DESIGN REMAIN THE PROPERTY OF EUROPEAN WROUGHT IRON WORKS LTD.

FINISH: Custom

DRAWING NUMBER: RC-05a

REV: 1- A

Pineapple, Pyramid, Ball or Spear Post Cap

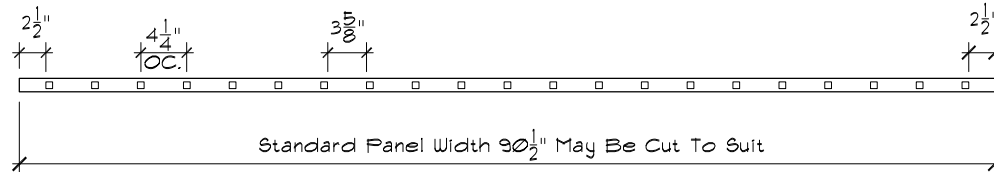
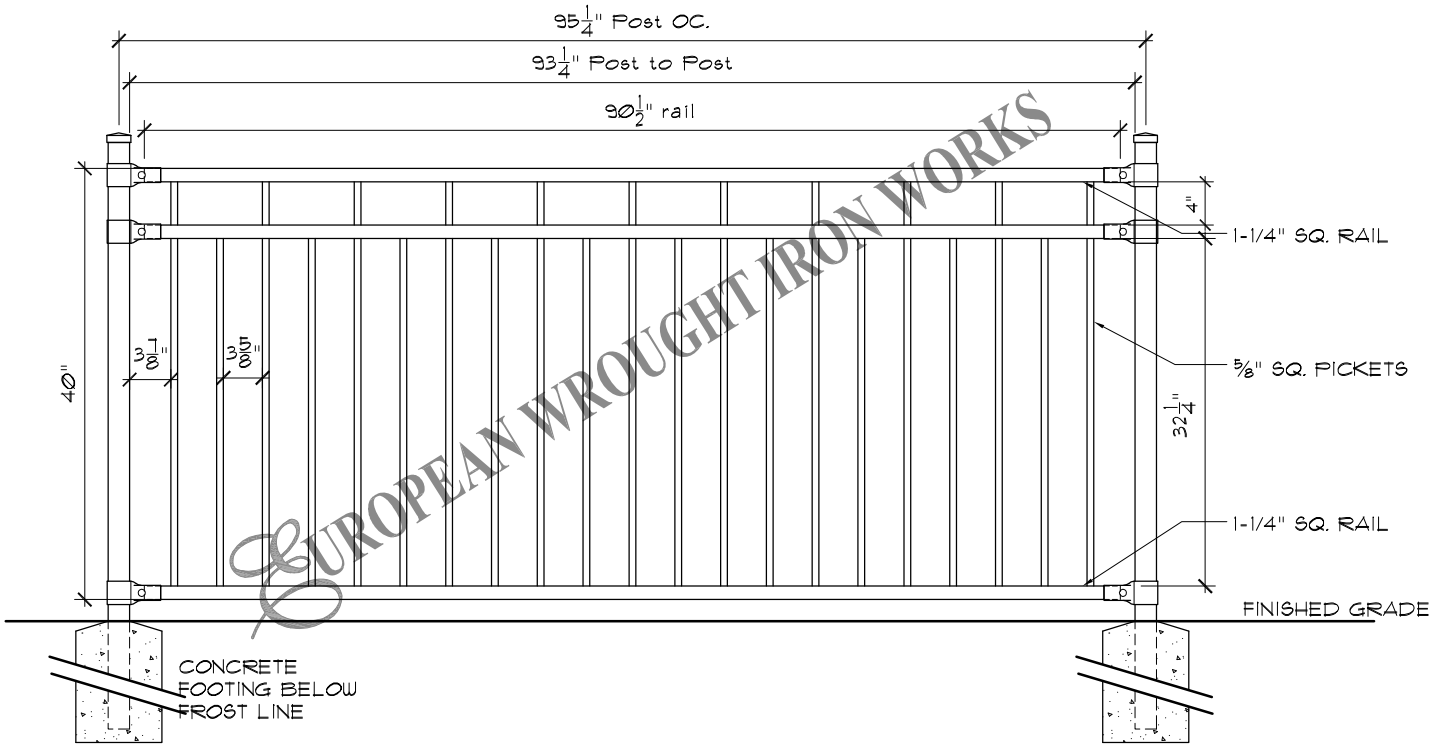
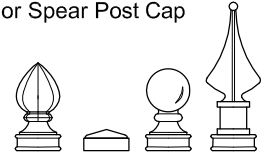

TYPICAL RAIL SECTION

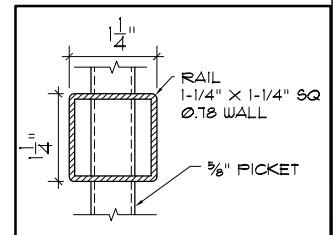

Specifications

<p>POST, RAILS & PICKETS: Cold Formed Steel Tubing Interior And Exterior Galvalume Coating Chromate Conversion Coating Electrostatically Applied Thermally Bonded Polyester Powder Coating Minimum Film Thickness 2.5 Mils</p> <p>POSTS: 2" x 2" (51mm x 51mm) 16 Gauge Standard Post Spacing 97-1/8" (2466mm) OC.</p> <p>POST CAP: Pyramid, Ball or Spear</p> <p>RAILS: 1-1/4" x 1-1/4" (32mm x 32mm) 14 Gauge</p> <p>PICKETS: 5/8" x 5/8" (15mm x 15mm) 16 Gauge</p>	<p>FITTINGS: 15 Gauge Stamp Forged Factory Finish. As Above</p> <p>WELDS: Stainless Steel</p> <p>STANDARD PANEL WIDTH: 91-1/2" (2324mm)</p> <p>AVAILABLE PANEL HEIGHTS: 48" (1219mm) (plus cap if applicable) 60" (1524mm) 72" (1828mm)</p> <p>NOTE: Tamper Proof Nut Available For Brackets</p> <p>COLOURS: Standard - High Gloss Black Optional Colours - Brown, Forest Green & Matt Black Custom Colours Available Upon Request.</p>
---	---

The following note shall apply to all drawings and associated documents:
 1. Copyright of this drawing and design is reserved by the Designer & European Wrought Iron Works Ltd. The drawing and all associated documents are an instrument of service by the Designer & European Wrought Iron Works Ltd. The drawing and the information contained therein may not be reproduced in whole or in part without prior written or verbal permission of the designer or European Wrought Iron Works Ltd.
 2. Drawings are not to be scaled for construction. All existing site conditions and dimensions required to perform the work are to be verified and any discrepancies are to be reported to the designer & European Wrought Iron Works Ltd.
 3. These drawings are not to be used for construction unless noted below as "Issued for Construction"
 4. All work to be carried out in conformance with the Code and Bylaws of the authorities having jurisdiction.
 5. The Designer of these plans and specifications gives no warranty or representation to any party about the constructability of the item represented by them.

CONFIDENTIAL: NOT TO BE DISCLOSED OR REPRODUCED

EUROPEAN WROUGHT IRON WORKS

WITHOUT THE WRITTEN PERMISSION OF EUROPEAN WROUGHT IRON WORKS LTD.

TITLE: Royalty Collection
Lord Custom with. Dbl. Top Rail

TOLERANCES INCHES UNLESS OTHERWISE NOTED
 X.XXX" ±0.005"
 X.XX" ±0.05"
 X.X" ±0.25"
 FRACTIONAL ±1/16"
 ANGULAR ±1°

SCALE: NTS.
DATE DRAWN: June 2015
DRAWN BY: DCM

DO NOT MODIFY OR SCALE DRAWING

PROJECT TITLE:

DESIGN: P.D.
SHEET NO.: 5b

DRAWING & DESIGN REMAIN THE PROPERTY OF EUROPEAN WROUGHT IRON WORKS LTD.

FINISH: Custom
DRAWING NUMBER: RC-05b
REV: 1-
A

Pineapple, Pyramid, Ball or Spear Post Cap

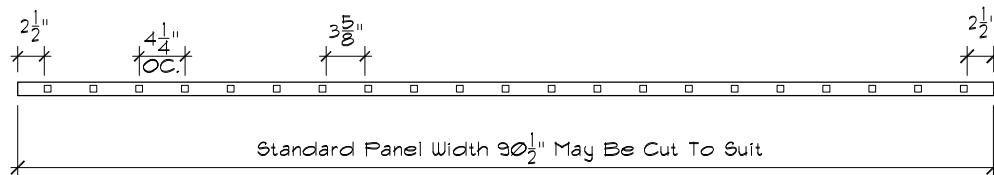
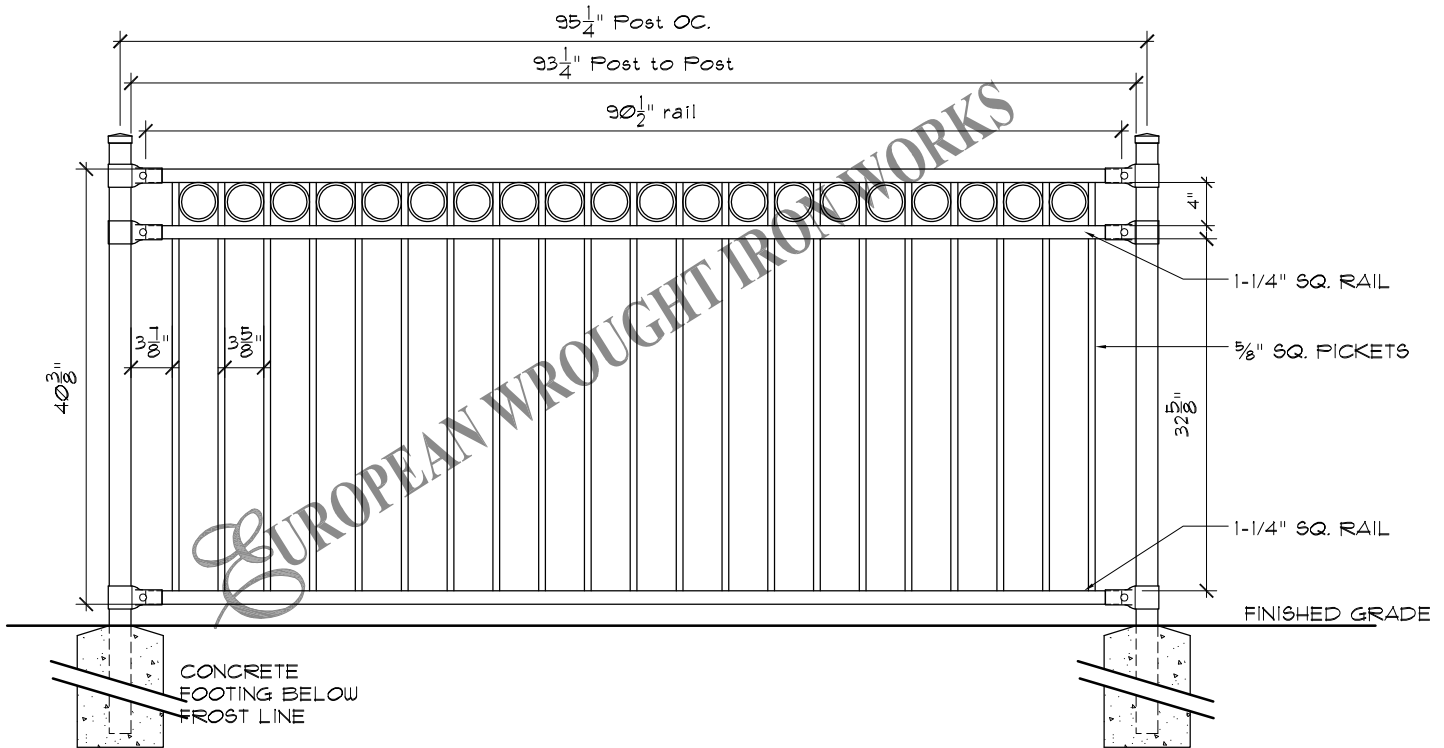
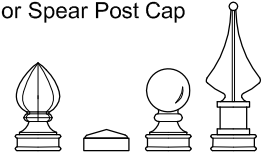

TYPICAL RAIL SECTION

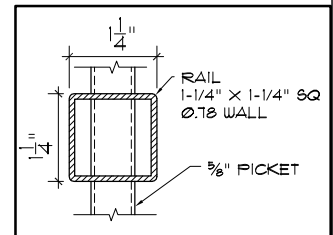

Specifications

POST, RAILS & PICKETS:	Cold Formed Steel Tubing Interior And Exterior Galvalume Coating Chromate Conversion Coating Electrostatically Applied Thermally Bonded Polyester Powder Coating Minimum Film Thickness 2.5 Mils	FITTINGS:	15 Gauge Stamp Forged Factory Finish. As Above
POSTS:	2" x 2" (51mm x 51mm) 16 Gauge Standard Post Spacing 97-1/8" (2466mm) OC.	WELDS:	Stainless Steel
POST CAP:	Pyramid, Ball or Spear	STANDARD PANEL WIDTH:	91-1/2" (2324m)
RAILS:	1-1/4" x 1-1/4" (32mm x 32mm) 14 Gauge	AVAILABLE PANEL HEIGHTS:	48" (1219mm) (plus cap if applicable) 60" (1524mm) 72" (1828mm)
PICKETS:	5/8" x 5/8" (15mm x 15mm) 16 Gauge	NOTE:	Tamper Proof Nut Available For Brackets
		COLOURS:	Standard - High Gloss Black Optional Colours - Brown, Forest Green & Matt Black Custom Colours Available Upon Request.

The following note shall apply to all drawings and associated documents:

- Copyright of this drawing and design is reserved by the Designer & European Wrought Iron Works Ltd. The drawing and all associated documents are an instrument of service by the Designer & European Wrought Iron Works Ltd. The drawing and the information contained therein may not be reproduced in whole or in part without prior written or verbal permission of the designer or European Wrought Iron Works Ltd.
- Drawings are not to be scaled for construction. All existing site conditions and dimensions required to perform the work are to be verified and any discrepancies are to be reported to the designer & European Wrought Iron Works Ltd.
- These drawings are not to be used for construction unless noted below as "Issued for Construction"
- All work to be carried out in conformance with the Code and Bylaws of the authorities having jurisdiction.
- The Designer of these plans and specifications gives no warranty or representation to any party about the constructability of the item represented by them.

CONFIDENTIAL: NOT TO BE DISCLOSED OR REPRODUCED



TITLE:
Royalty Collection
Lord Custom with Circle

TOLERANCES
INCHES
UNLESS OTHERWISE NOTED
".XXX" ±0.005"
".XX" ±0.05"
".X" ±0.25"
FRACTIONAL ±1/16"
ANGULAR ±1°

SCALE: NTS.
DATE DRAWN: June 2015
DRAWN BY: DCM

DO NOT
MODIFY OR
SCALE DRAWING

PROJECT TITLE:

DRAWING & DESIGN REMAIN THE PROPERTY OF EUROPEAN WROUGHT IRON WORKS LTD.

DESIGN: P.D.
SHEET NO: 5c

FINISH: Custom
DRAWING NUMBER: RC-05c

REV 1- A

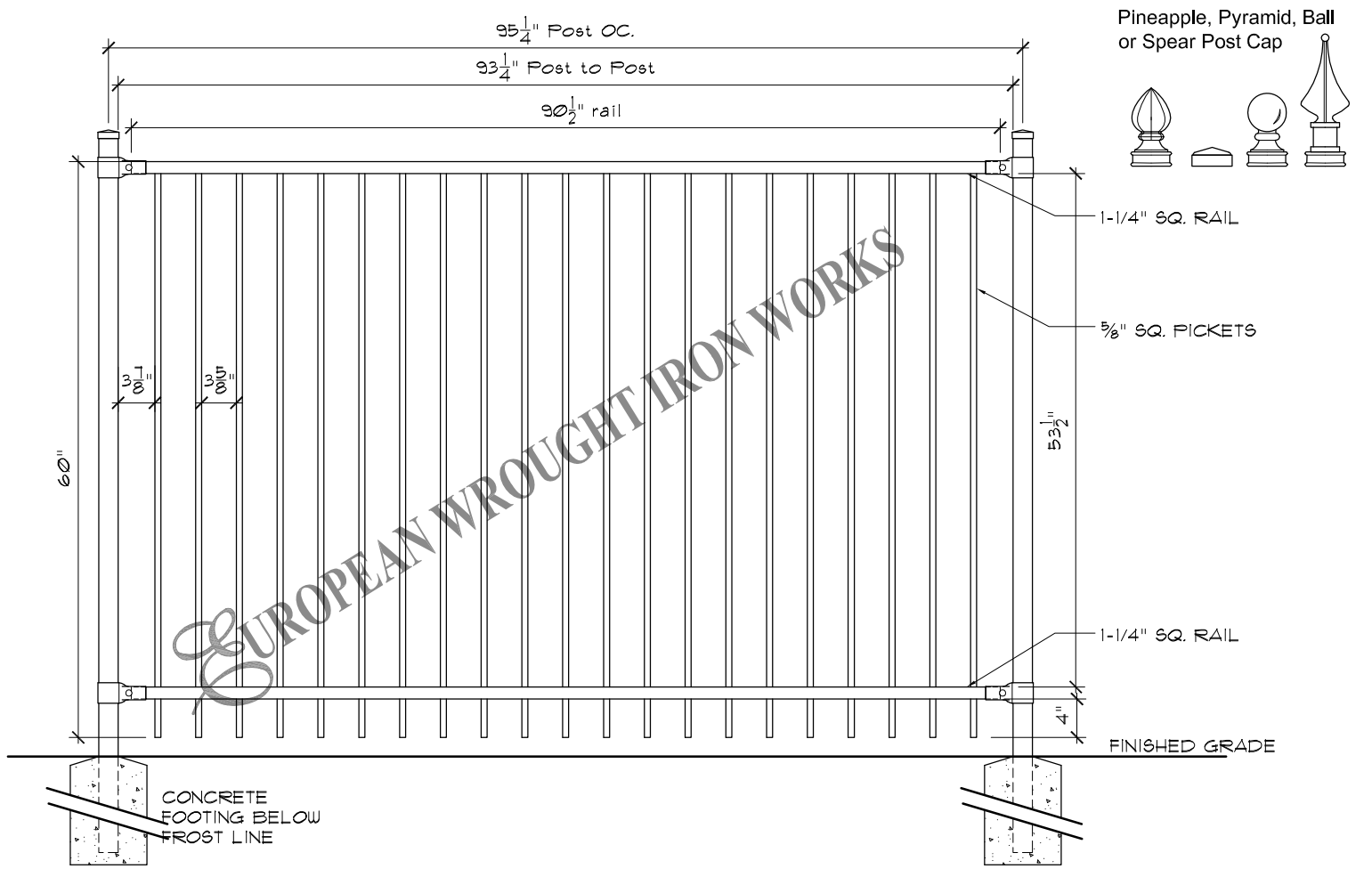

Pineapple, Pyramid, Ball or Spear Post Cap

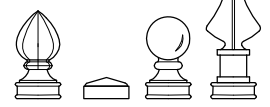

1-1/4" SQ. RAIL

5/8" SQ. PICKETS

1-1/4" SQ. RAIL

FINISHED GRADE

CONCRETE FOOTING BELOW FROST LINE

TYPICAL RAIL SECTION

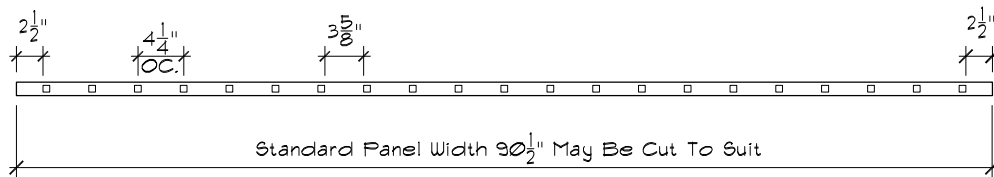
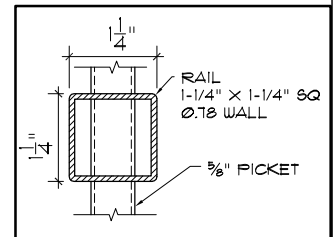

Specifications

POST, RAILS & PICKETS:	Cold Formed Steel Tubing Interior And Exterior Galvalume Coating Chromate Conversion Coating Electrostatically Applied Thermally Bonded Polyester Powder Coating Minimum Film Thickness 2.5 Mils	FITTINGS:	15 Gauge Stamp Forged Factory Finish. As Above
POSTS:	2" x 2" (51mm x 51mm) 16 Gauge Standard Post Spacing 97-1/8" (2466mm) OC.	WELDS:	Stainless Steel
POST CAP:	Pyramid, Ball or Spear	STANDARD PANEL WIDTH:	91-1/2" (2324mm)
RAILS:	1-1/4" x 1-1/4" (32mm x 32mm) 14 Gauge	AVAILABLE PANEL HEIGHTS:	48" (1219mm) (plus cap if applicable) 60" (1524mm) 72" (1828mm)
PICKETS:	5/8" x 5/8" (15mm x 15mm) 16 Gauge	NOTE:	Tamper Proof Nut Available For Brackets
		COLOURS:	Standard - High Gloss Black Optional Colours - Brown, Forest Green & Matt Black Custom Colours Available Upon Request.

The following note shall apply to all drawings and associated documents:
 1. Copyright of this drawing and design is reserved by the Designer & European Wrought Iron Works Ltd. The drawing and all associated documents are an instrument of service by the Designer & European Wrought Iron Works Ltd. The drawing and the information contained therein may not be reproduced in whole or in part without prior written or verbal permission of the designer or European Wrought Iron Works Ltd.
 2. Drawings are not to be scaled for construction. All existing site conditions and dimensions required to perform the work are to be verified and any discrepancies are to be reported to the designer & European Wrought Iron Works Ltd.
 3. These drawings are not to be used for construction unless noted below as "Issued for Construction"
 4. All work to be carried out in conformance with the Code and Bylaws of the authorities having jurisdiction.
 5. The Designer of these plans and specifications gives no warranty or representation to any party about the constructability of the item represented by them.

CONFIDENTIAL: NOT TO BE DISCLOSED OR REPRODUCED

EUROPEAN WROUGHT IRON WORKS

WITHOUT THE WRITTEN PERMISSION OF EUROPEAN WROUGHT IRON WORKS LTD.

TITLE:
Royalty Collection
Lord Custom

TOLERANCES INCHES UNLESS OTHERWISE NOTED	X.XX" ±0.005" X.X" ±0.05" X.X" ±0.25" FRACTIONAL ±1/16" ANGULAR ±1°
SCALE:	NTS.
DATE DRAWN:	June 2015
DRAWN BY:	DCM

DO NOT MODIFY OR SCALE DRAWING	DRAWING & DESIGN REMAIN THE PROPERTY OF EUROPEAN WROUGHT IRON WORKS LTD.		
PROJECT TITLE:			
DESIGN:	P.D.	FINISH:	Custom
SHEET NO:	5d	DRAWING NUMBER:	RC-05d
		REV	1- A

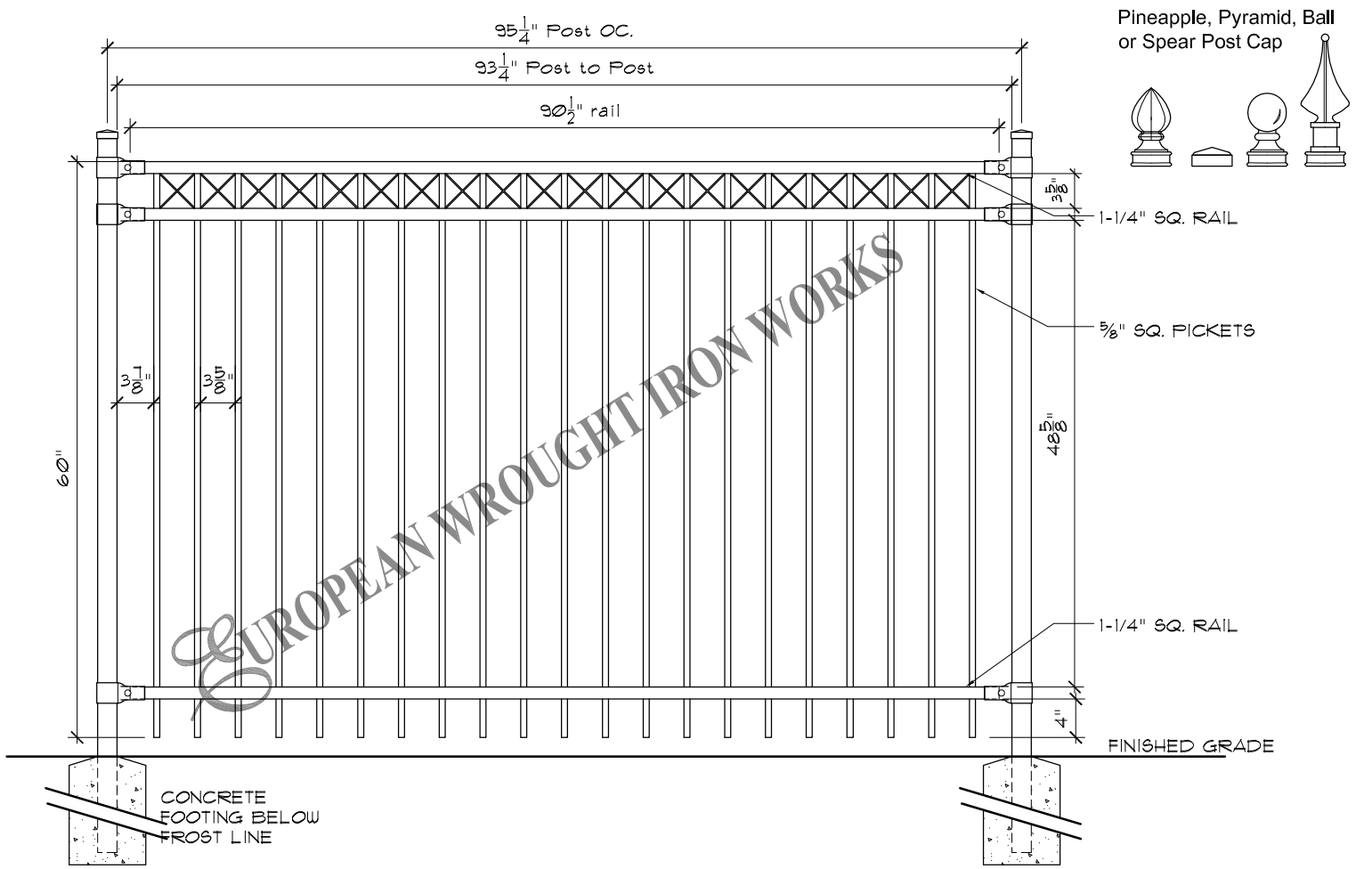

Pineapple, Pyramid, Ball or Spear Post Cap

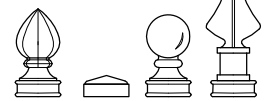

1-1/4" SQ. RAIL
 5/8" SQ. PICKETS
 48"
 1-1/4" SQ. RAIL
 4"
 FINISHED GRADE

EUROPEAN WROUGHT IRON WORKS

TYPICAL RAIL SECTION

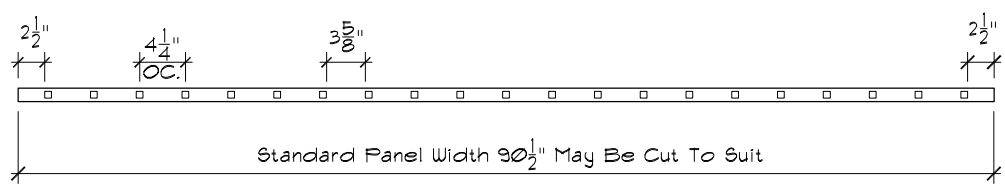
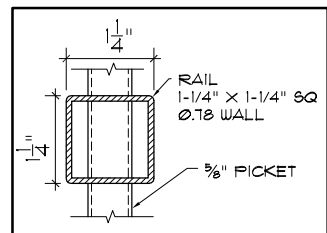

Specifications

<p>POST, RAILS & PICKETS: Cold Formed Steel Tubing Interior And Exterior Galvalume Coating Chromate Conversion Coating Electrostatically Applied Thermally Bonded Polyester Powder Coating Minimum Film Thickness 2.5 Mills</p> <p>POSTS: 2" x 2" (51mm x 51mm) 16 Gauge Standard Post Spacing 97-1/8" (2466mm) OC.</p> <p>POST CAP: Pyramid, Ball or Spear</p> <p>RAILS: 1-1/4" x 1-1/4" (32mm x 32mm) 14 Gauge</p> <p>PICKETS: 5/8" x 5/8" (15mm x 15mm) 16 Gauge</p>	<p>FITTINGS: 15 Gauge Stamp Forged Factory Finish. As Above</p> <p>WELDS: Stainless Steel</p> <p>STANDARD PANEL WIDTH: 91-1/2" (2324mm)</p> <p>AVAILABLE PANEL HEIGHTS: 48" (1219mm) (plus cap if applicable) 60" (1524mm) 72" (1828mm)</p> <p>NOTE: Tamper Proof Nut Available For Brackets</p> <p>COLOURS: Standard - High Gloss Black Optional Colours - Brown, Forest Green & Matt Black Custom Colours Available Upon Request.</p>
--	---

The following note shall apply to all drawings and associated documents:
 1. Copyright of this drawing and design is reserved by the Designer & European Wrought Iron Works Ltd. The drawing and all associated documents are an instrument of service by the Designer & European Wrought Iron Works Ltd. The drawing and the information contained therein may not be reproduced in whole or in part without prior written or verbal permission of the designer or European Wrought Iron Works Ltd.
 2. Drawings are not to be scaled for construction. All existing site conditions and dimensions required to perform the work are to be verified and any discrepancies are to be reported to the designer & European Wrought Iron Works Ltd.
 3. These drawings are not to be used for construction unless noted below as "Issued for Construction"
 4. All work to be carried out in conformance with the Code and Bylaws of the authorities having jurisdiction.
 5. The Designer of these plans and specifications gives no warranty or representation to any party about the constructability of the item represented by them.

CONFIDENTIAL: NOT TO BE DISCLOSED OR REPRODUCED

EUROPEAN WROUGHT IRON WORKS

WITHOUT THE WRITTEN PERMISSION OF EUROPEAN WROUGHT IRON WORKS LTD.

TITLE:
Royalty Collection
Lord Custom with Cross II

TOLERANCES INCHES UNLESS OTHERWISE NOTED
 X.XXX" ±0.005"
 X.XX" ±0.05"
 X.X" ±0.25"
 FRACTIONAL ±1/16"
 ANGULAR ±1°

SCALE: NTS.
DATE DRAWN: June 2015
DRAWN BY: DCM

DO NOT MODIFY OR SCALE DRAWING

PROJECT TITLE:

DESIGN: P.D.
SHEET NO.: 5e

DRAWING & DESIGN REMAIN THE PROPERTY OF EUROPEAN WROUGHT IRON WORKS LTD.

FINISH: Custom
DRAWING NUMBER: RC-05e
REV: 1-
A

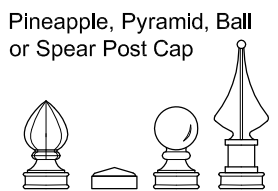
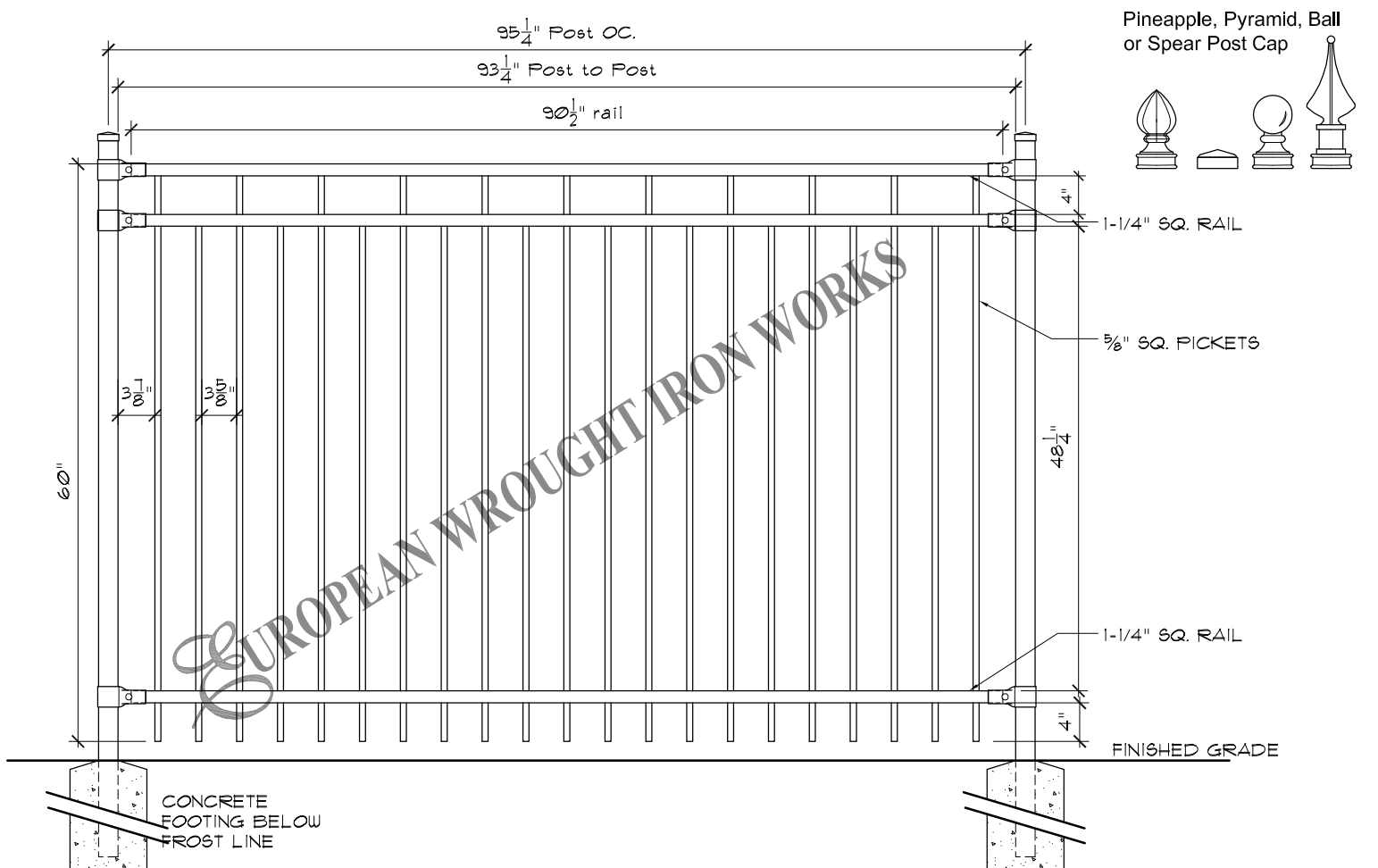

EUROPEAN WROUGHT IRON WORKS

TYPICAL RAIL SECTION

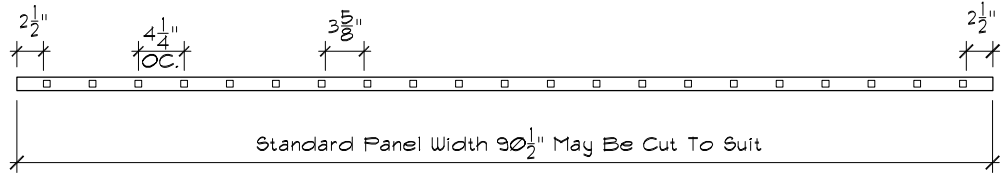
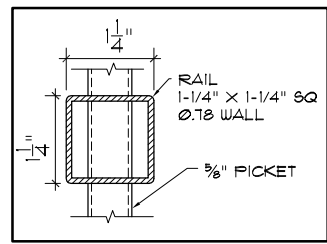

Specifications

<p>POST, RAILS & PICKETS: Cold Formed Steel Tubing Interior And Exterior Galvalume Coating Chromate Conversion Coating Electrostatically Applied Thermally Bonded Polyester Powder Coating Minimum Film Thickness 2.5 Mills</p> <p>POSTS: 2" x 2" (51mm x 51mm) 16 Gauge Standard Post Spacing 97-1/8" (2466mm) OC.</p> <p>POST CAP: Pyramid, Ball or Spear</p> <p>RAILS: 1-1/4" x 1-1/4" (32mm x 32mm) 14 Gauge</p> <p>PICKETS: 5/8" x 5/8" (15mm x 15mm) 16 Gauge</p>	<p>FITTINGS: 15 Gauge Stamp Forged Factory Finish. As Above</p> <p>WELDS: Stainless Steel</p> <p>STANDARD PANEL WIDTH: 91-1/2" (2324mm)</p> <p>AVAILABLE PANEL HEIGHTS: 48" (1219mm) (plus cap if applicable) 60" (1524mm) 72" (1828mm)</p> <p>NOTE: Tamper Proof Nut Available For Brackets</p> <p>COLOURS: Standard - High Gloss Black Optional Colours - Brown, Forest Green & Matt Black Custom Colours Available Upon Request.</p>
--	---

The following note shall apply to all drawings and associated documents:

- Copyright of this drawing and design is reserved by the Designer & European Wrought Iron Works Ltd. The drawing and all associated documents are an instrument of service by the Designer & European Wrought Iron Works Ltd. The drawing and the information contained therein may not be reproduced in whole or in part without prior written or verbal permission of the designer or European Wrought Iron Works Ltd.
- Drawings are not to be scaled for construction. All existing site conditions and dimensions required to perform the work are to be verified and any discrepancies are to be reported to the designer & European Wrought Iron Works Ltd.
- These drawings are not to be used for construction unless noted below as "Issued for Construction"
- All work to be carried out in conformance with the Code and Bylaws of the authorities having jurisdiction.
- The Designer of these plans and specifications gives no warranty or representation to any party about the constructability of the item represented by them.

CONFIDENTIAL: NOT TO BE DISCLOSED OR REPRODUCED

EUROPEAN
WROUGHT IRON WORKS

WITHOUT THE WRITTEN PERMISSION OF EUROPEAN WROUGHT IRON WORKS LTD.

TITLE: **Royalty Collection**
Lord Custom with Dbl. Top Rail II

TOLERANCES
INCHES
UNLESS OTHERWISE NOTED
X.XXX" ±0.005"
X.XX" ±0.05"
X.X" ±0.25"
FRACTIONAL ±1/16"
ANGULAR ±1°

SCALE: NTS.

DATE DRAWN: June 2015

DRAWN BY: DCM

DO NOT MODIFY OR SCALE DRAWING

PROJECT TITLE:

DESIGN: P.D.

SHEET NO.: 5f

DRAWING & DESIGN REMAIN THE PROPERTY OF EUROPEAN WROUGHT IRON WORKS LTD.	
FINISH: Custom	REV
DRAWING NUMBER: RC-05f	1- A

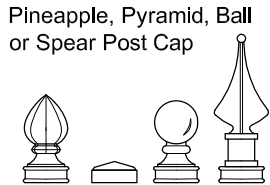
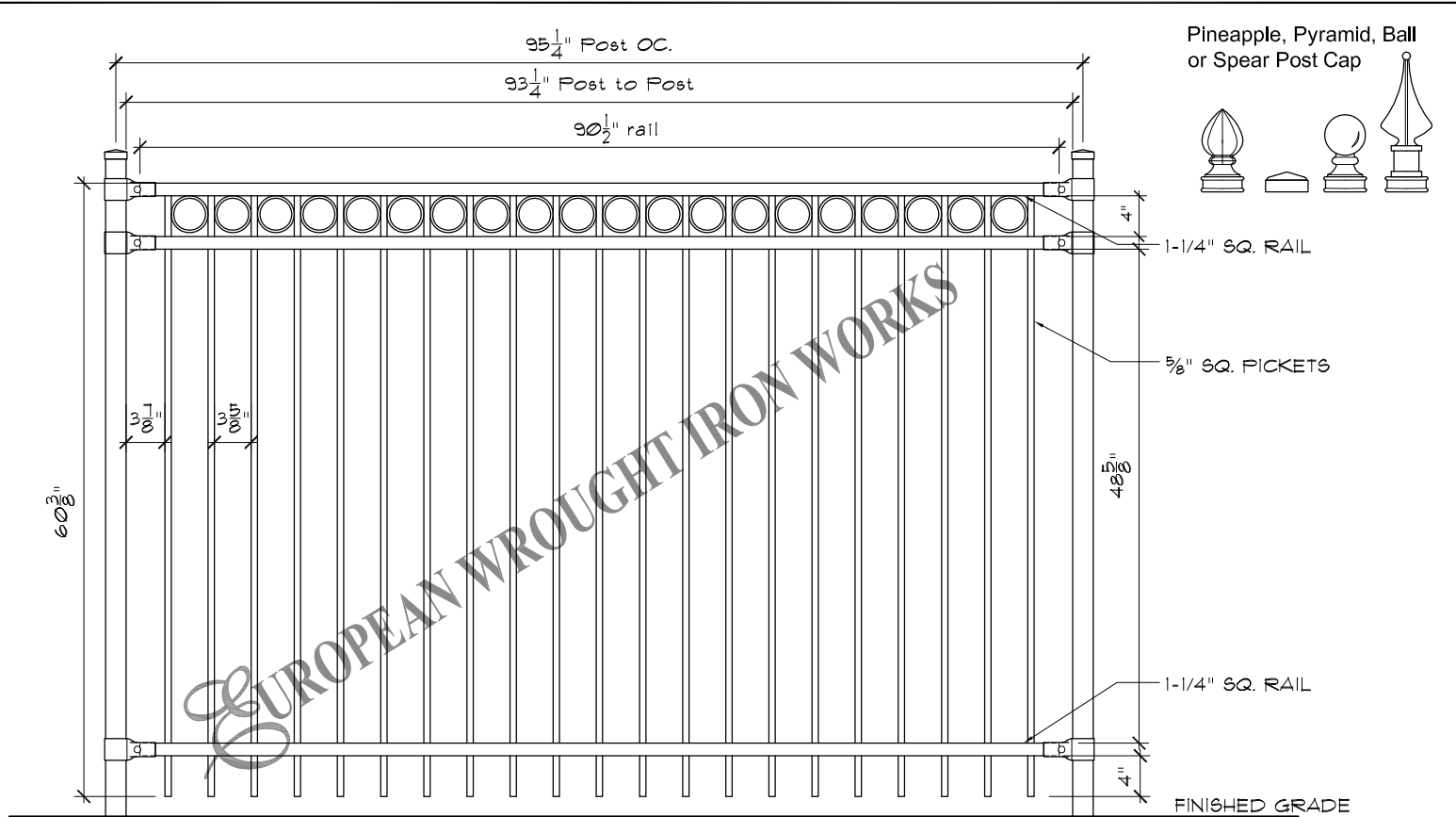

1-1/4" SQ. RAIL

5/8" SQ. PICKETS

1-1/4" SQ. RAIL

FINISHED GRADE

EUROPEAN WROUGHT IRON WORKS

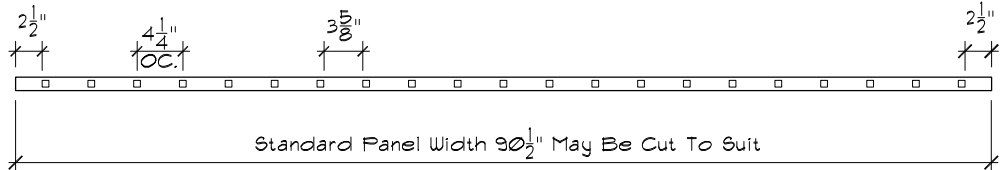

TYPICAL RAIL SECTION

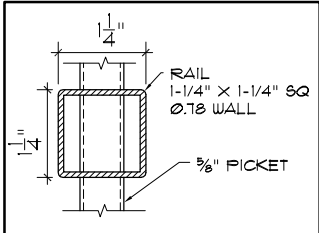

Specifications

<p>POST, RAILS & PICKETS: Cold Formed Steel Tubing Interior And Exterior Galvalume Coating Chromate Conversion Coating Electrostatically Applied Thermally Bonded Polyester Powder Coating Minimum Film Thickness 2.5 Mils</p> <p>POSTS: 2" x 2" (51mm x 51mm) 16 Gauge Standard Post Spacing 97-1/8" (2466mm) OC.</p> <p>POST CAP: Pyramid, Ball or Spear</p> <p>RAILS: 1-1/4" x 1-1/4" (32mm x 32mm) 14 Gauge</p> <p>PICKETS: 5/8" x 5/8" (15mm x 15mm) 16 Gauge</p>	<p>FITTINGS: 15 Gauge Stamp Forged Factory Finish. As Above</p> <p>WELDS: Stainless Steel</p> <p>STANDARD PANEL WIDTH: 91-1/2" (2324mm)</p> <p>AVAILABLE PANEL HEIGHTS: 48" (1219mm) (plus cap if applicable) 60" (1524mm) 72" (1828mm)</p> <p>NOTE: Tamper Proof Nut Available For Brackets</p> <p>COLOURS: Standard - High Gloss Black Optional Colours - Brown, Forest Green & Matt Black Custom Colours Available Upon Request.</p>
---	---

The following note shall apply to all drawings and associated documents:
 1. Copyright of this drawing and design is reserved by the Designer & European Wrought Iron Works Ltd. The drawing and all associated documents are an instrument of service by the Designer & European Wrought Iron Works Ltd. The drawing and the information contained therein may not be reproduced in whole or in part without prior written or verbal permission of the designer or European Wrought Iron Works Ltd.
 2. Drawings are not to be scaled for construction. All existing site conditions and dimensions required to perform the work are to be verified and any discrepancies are to be reported to the designer & European Wrought Iron Works Ltd.
 3. These drawings are not to be used for construction unless noted below as "Issued for Construction"
 4. All work to be carried out in conformance with the Code and Bylaws of the authorities having jurisdiction.
 5. The Designer of these plans and specifications gives no warranty or representation to any party about the constructability of the item represented by them.

CONFIDENTIAL: NOT TO BE DISCLOSED OR REPRODUCED

EUROPEAN WROUGHT IRON WORKS

WITHOUT THE WRITTEN PERMISSION OF EUROPEAN WROUGHT IRON WORKS LTD.

TITLE: **Royalty Collection**
Lord Custom with Circle II

TOLERANCES INCHES UNLESS OTHERWISE NOTED X.XXX" ±0.005" X.XX" ±0.05" X.X" ±0.25" FRACTIONAL ±1/16" ANGULAR ±1°
SCALE: NTS.
DATE DRAWN: June 2015
DRAWN BY: DCM

DO NOT MODIFY OR SCALE DRAWING
PROJECT TITLE:
DESIGN: P.D.
SHEET NO: 5g

DRAWING & DESIGN REMAIN THE PROPERTY OF EUROPEAN WROUGHT IRON WORKS LTD.	
FINISH:	Custom
DRAWING NUMBER:	RC-05g
REV	1-
A	A

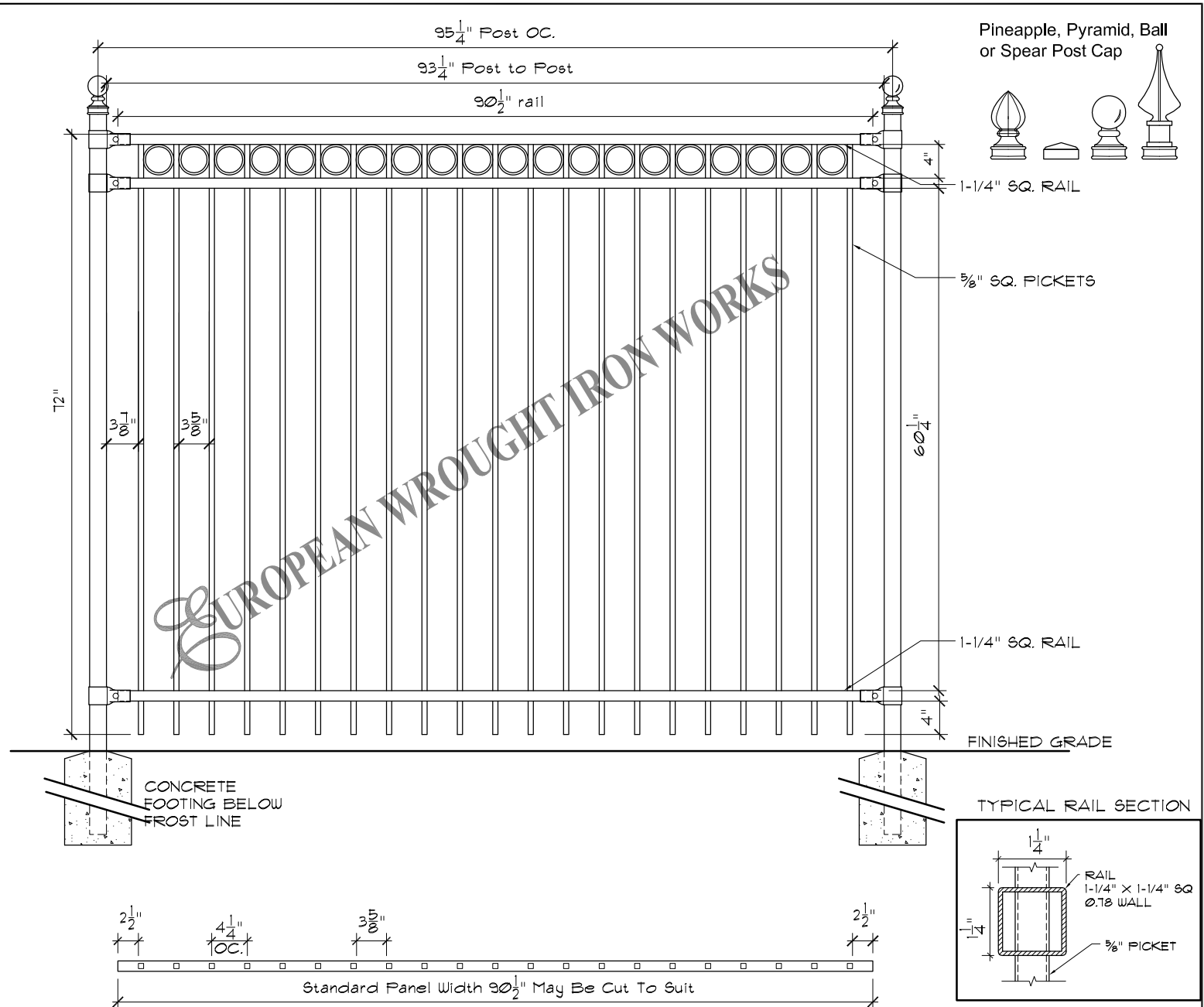

Specifications

POST, RAILS & PICKETS:	Cold Formed Steel Tubing Interior And Exterior Galvalume Coating Chromate Conversion Coating Electrostatically Applied Thermally Bonded Polyester Powder Coating Minimum Film Thickness 2.5 Mils	FITTINGS:	15 Gauge Stamp Forged Factory Finish. As Above
POSTS:	2" x 2" (51mm x 51mm) 16 Gauge Standard Post Spacing 97-1/8" (2466mm) OC.	WELDS:	Stainless Steel
POST CAP:	Pyramid, Ball or Spear	STANDARD PANEL WIDTH:	91-1/2" (2324mm)
RAILS:	1-1/4" x 1-1/4" (32mm x 32mm) 14 Gauge	AVAILABLE PANEL HEIGHTS:	48" (1219mm) (plus cap if applicable) 60" (1524mm) 72" (1828mm)
PICKETS:	5/8" x 5/8" (15mm x 15mm) 16 Gauge	NOTE:	Tamper Proof Nut Available For Brackets
		COLOURS:	Standard - High Gloss Black Optional Colours - Brown, Forest Green & Matt Black Custom Colours Available Upon Request.

The following note shall apply to all drawings and associated documents:

- Copyright of this drawing and design is reserved by the Designer & European Wrought Iron Works Ltd. The drawing and all associated documents are an instrument of service by the Designer & European Wrought Iron Works Ltd. The drawing and the information contained therein may not be reproduced in whole or in part without prior written or verbal permission of the designer or European Wrought Iron Works Ltd.
- Drawings are not to be scaled for construction. All existing site conditions and dimensions required to perform the work are to be verified and any discrepancies are to be reported to the designer & European Wrought Iron Works Ltd.
- These drawings are not to be used for construction unless noted below as "Issued for Construction"
- All work to be carried out in conformance with the Code and Bylaws of the authorities having jurisdiction.
- The Designer of these plans and specifications gives no warranty or representation to any party about the constructability of the item represented by them.

CONFIDENTIAL: NOT TO BE DISCLOSED OR REPRODUCED



TITLE: **Royalty Collection**
Lord Custom with Circle II

TOLERANCES
INCHES
UNLESS OTHERWISE NOTED
X.XXX" ±0.005"
X.XX" ±0.05"
X.X" ±0.25"
FRACTIONAL ±1/16"
ANGULAR ±1°

SCALE: NTS.
DATE DRAWN: June 2015
DRAWN BY: DCM

DO NOT
MODIFY OR
SCALE DRAWING

DRAWING & DESIGN REMAIN THE PROPERTY OF EUROPEAN WROUGHT IRON WORKS LTD.

PROJECT TITLE:

DESIGN: P.D.
SHEET NO: 5g

FINISH: Custom
DRAWING NUMBER: RC-05g

REV 1- A

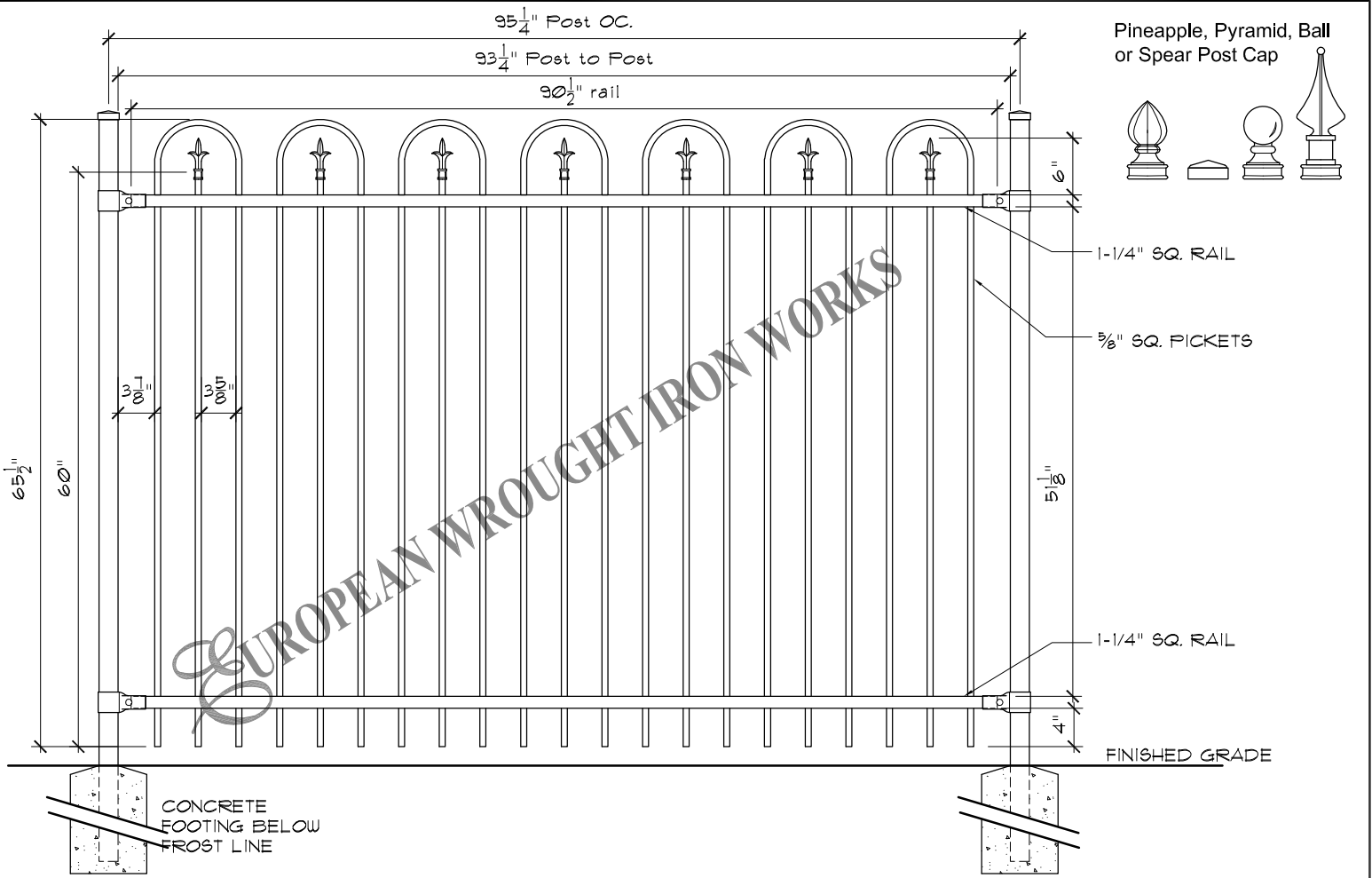

Pineapple, Pyramid, Ball or Spear Post Cap

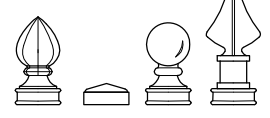

1-1/4" SQ. RAIL

5/8" SQ. PICKETS

1-1/4" SQ. RAIL

FINISHED GRADE

CONCRETE FOOTING BELOW FROST LINE

TYPICAL RAIL SECTION

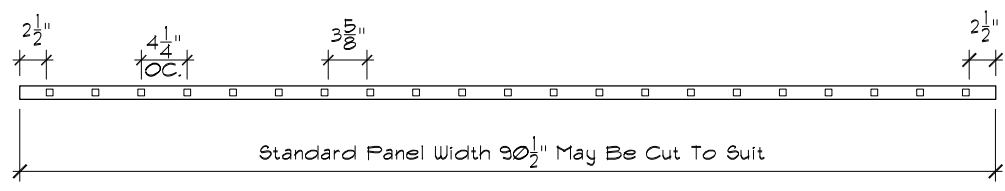
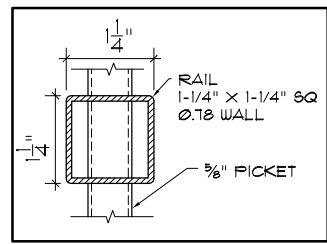

Specifications

<p>POST, RAILS & PICKETS: Cold Formed Steel Tubing Interior And Exterior Galvalume Coating Chromate Conversion Coating Electrostatically Applied Thermally Bonded Polyester Powder Coating Minimum Film Thickness 2.5 Mils</p> <p>POSTS: 2" x 2" (51mm x 51mm) 16 Gauge Standard Post Spacing 97-1/8" (2466mm) OC.</p> <p>POST CAP: Pyramid, Ball or Spear</p> <p>RAILS: 1-1/4" x 1-1/4" (32mm x 32mm) 14 Gauge</p> <p>PICKETS: 5/8" x 5/8" (15mm x 15mm) 16 Gauge</p>	<p>FITTINGS: 15 Gauge Stamp Forged Factory Finish. As Above</p> <p>WELDS: Stainless Steel</p> <p>STANDARD PANEL WIDTH: 91-1/2" (2324mm)</p> <p>AVAILABLE PANEL HEIGHTS: 48" (1219mm) (plus cap if applicable) 60" (1524mm) 72" (1828mm)</p> <p>NOTE: Tamper Proof Nut Available For Brackets</p> <p>COLOURS: Standard - High Gloss Black Optional Colours - Brown, Forest Green & Matt Black Custom Colours Available Upon Request.</p>
---	---

The following note shall apply to all drawings and associated documents:
 1. Copyright of this drawing and design is reserved by the Designer & European Wrought Iron Works Ltd. The drawing and all associated documents are an instrument of service by the Designer & European Wrought Iron Works Ltd. The drawing and the information contained therein may not be reproduced in whole or in part without prior written or verbal permission of the designer or European Wrought Iron Works Ltd.
 2. Drawings are not to be scaled for construction. All existing site conditions and dimensions required to perform the work are to be verified and any discrepancies are to be reported to the designer & European Wrought Iron Works Ltd.
 3. These drawings are not to be used for construction unless noted below as "Issued for Construction"
 4. All work to be carried out in conformance with the Code and Bylaws of the authorities having jurisdiction.
 5. The Designer of these plans and specifications gives no warranty or representation to any party about the constructability of the item represented by them.

CONFIDENTIAL: NOT TO BE DISCLOSED OR REPRODUCED

EUROPEAN WROUGHT IRON WORKS

WITHOUT THE WRITTEN PERMISSION OF EUROPEAN WROUGHT IRON WORKS LTD.

TITLE: **Royalty Collection Queen**

TOLERANCES INCHES UNLESS OTHERWISE NOTED
 X.XXX" ±0.005"
 X.XX" ±0.05"
 X.X" ±0.25"
 FRACTIONAL ±1/16"
 ANGULAR ±1°

SCALE: NTS.

DATE DRAWN: June 2015

DRAWN BY: DCM

DO NOT MODIFY OR SCALE DRAWING

PROJECT TITLE:

DESIGN: P.D.

SHEET NO: 9

DRAWING & DESIGN REMAIN THE PROPERTY OF EUROPEAN WROUGHT IRON WORKS LTD.

FINISH: Custom

DRAWING NUMBER: RC-09

REV: 1- A

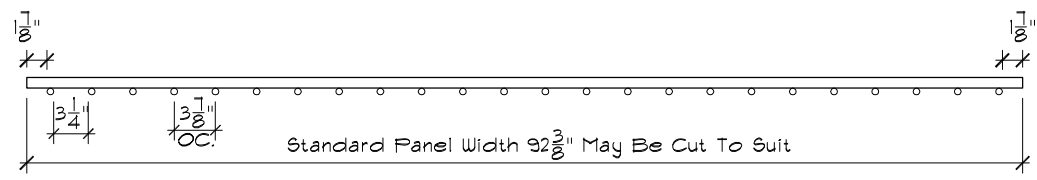
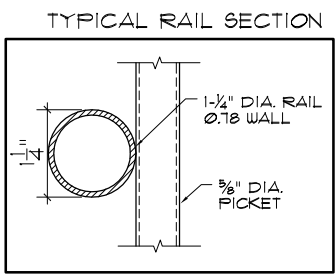
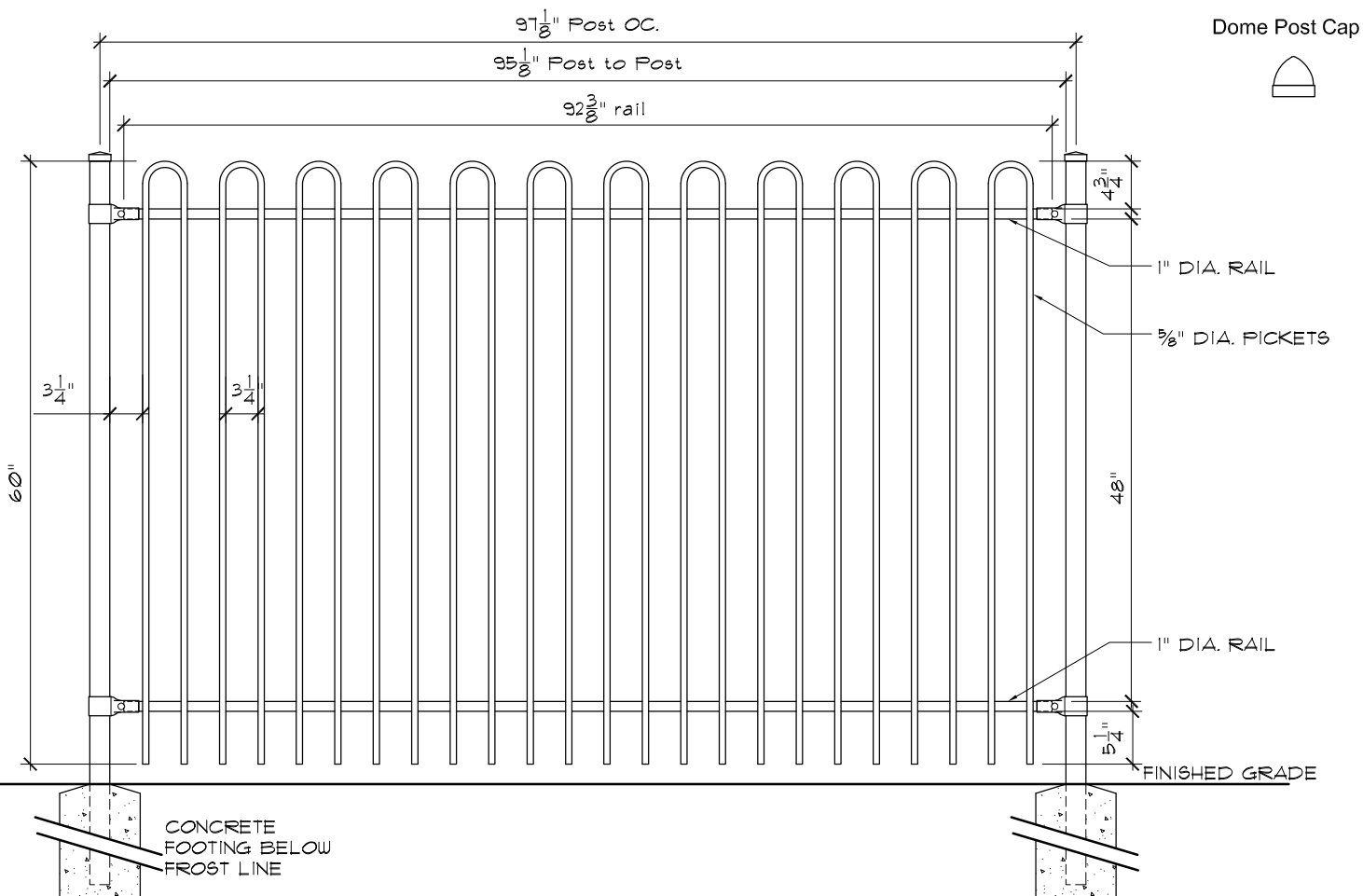

Specifications

<p>POST, RAILS & PICKETS: Cold Formed Steel Tubing Interior And Exterior Galvalume Coating Chromate Conversion Coating Electrostatically Applied Thermally Bonded Polyester Powder Coating Minimum Film Thickness 2.5 Mils</p> <p>POSTS: 2" x 2" (51mm x 51mm) 16 Gauge Standard Post Spacing 97-1/8" (2466mm) OC.</p> <p>POST CAP: Pyramid, Ball or Spear</p> <p>RAILS: 1-1/4" Round (32mm) 14 Gauge</p> <p>PICKETS: 5/8" Round (15mm) 16 Gauge</p>	<p>FITTINGS: 15 Gauge Stamp Forged Factory Finish. As Above</p> <p>WELDS: Stainless Steel</p> <p>STANDARD PANEL WIDTH: 92-3/8" (2346mm)</p> <p>AVAILABLE PANEL HEIGHTS: 48" (1219mm) (plus cap if applicable) 60" (1524mm) 72" (1828mm)</p> <p>NOTE: Tamper Proof Nut Available For Brackets</p> <p>COLOURS: Standard - High Gloss Black Optional Colours - Brown, Forest Green & Matt Black Custom Colours Available Upon Request.</p>
---	---

The following note shall apply to all drawings and associated documents:

- Copyright of this drawing and design is reserved by the Designer & European Wrought Iron Works Ltd. The drawing and all associated documents are an instrument of service by the Designer & European Wrought Iron Works Ltd. The drawing and the information contained therein may not be reproduced in whole or in part without prior written or verbal permission of the designer or European Wrought Iron Works Ltd.
- Drawings are not to be scaled for construction. All existing site conditions and dimensions required to perform the work are to be verified and any discrepancies are to be reported to the designer & European Wrought Iron Works Ltd.
- These drawings are not to be used for construction unless noted below as "Issued for Construction"
- All work to be carried out in conformance with the Code and Bylaws of the authorities having jurisdiction.
- The Designer of these plans and specifications gives no warranty or representation to any party about the constructability of the item represented by them.

CONFIDENTIAL: NOT TO BE DISCLOSED OR REPRODUCED



**ROYALTY COLLECTION
King**

TITLE: **Royalty Collection King**

TOLERANCES INCHES UNLESS OTHERWISE NOTED
 X.XXX" ±0.005"
 X.XX" ±0.05"
 X.X" ±0.25"
 FRACTIONAL ±1/16"
 ANGULAR ±1°

SCALE: NTS.

DATE DRAWN: June 2015

DRAWN BY: DCM

DO NOT MODIFY OR SCALE DRAWING

PROJECT TITLE:

DESIGN: P.D.

SHEET NO: 10

DRAWING & DESIGN REMAIN THE PROPERTY OF EUROPEAN WROUGHT IRON WORKS LTD.

FINISH: Custom

DRAWING NUMBER: RC-10

REV 1- A

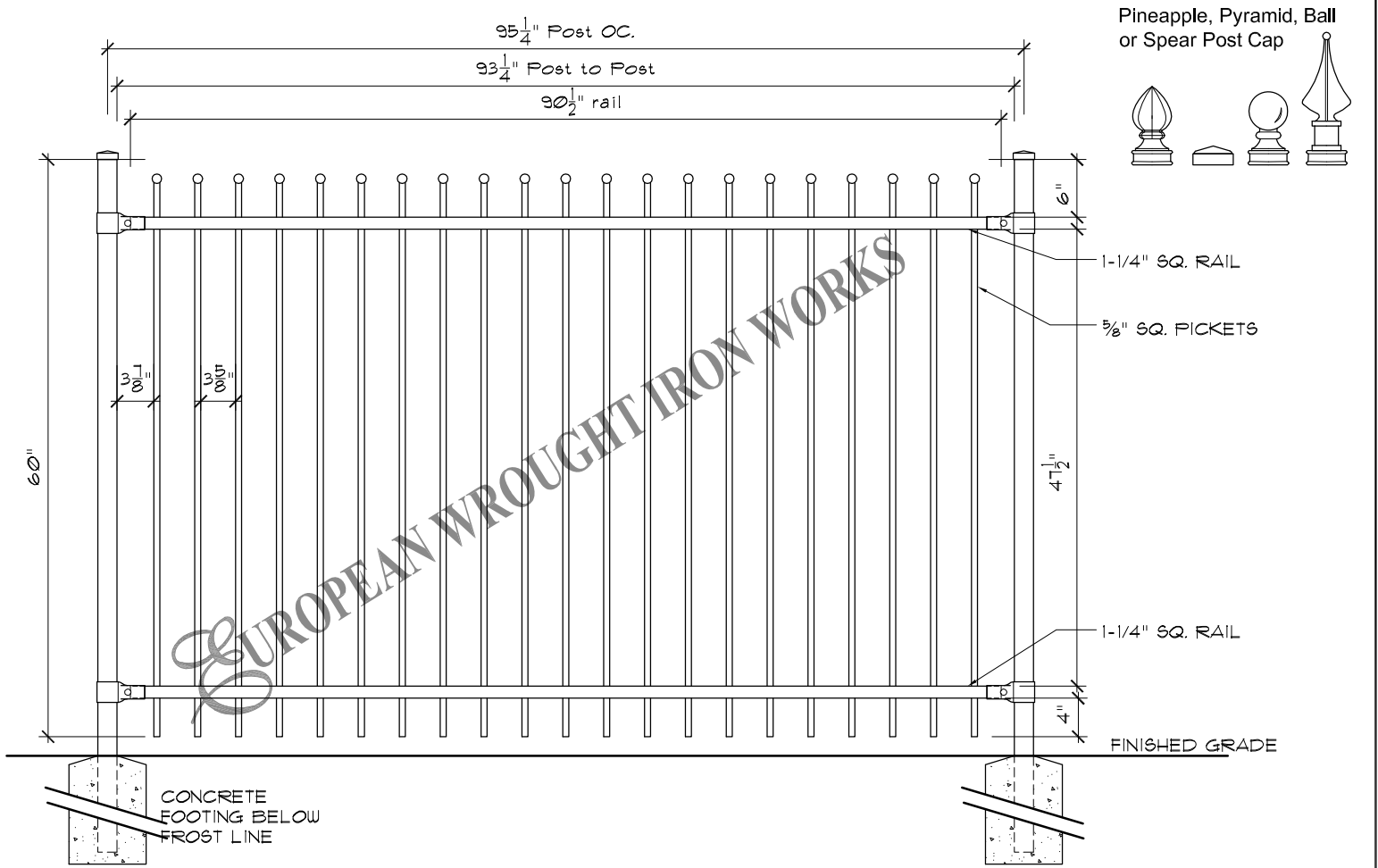

Pineapple, Pyramid, Ball or Spear Post Cap

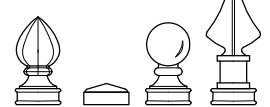

1-1/4" SQ. RAIL

5/8" SQ. PICKETS

1-1/4" SQ. RAIL

FINISHED GRADE

CONCRETE FOOTING BELOW FROST LINE

TYPICAL RAIL SECTION

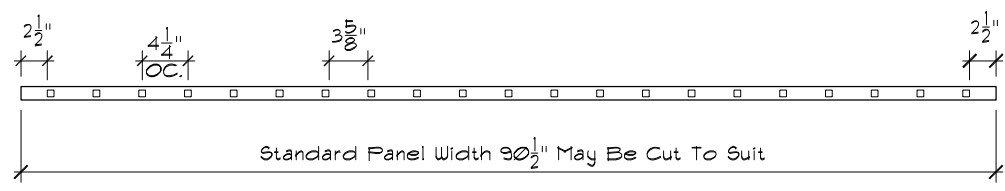
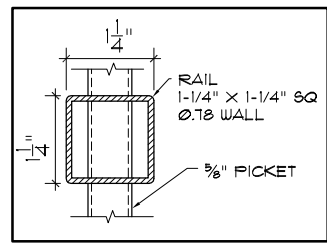

Specifications

<p>POST, RAILS & PICKETS: Cold Formed Steel Tubing Interior And Exterior Galvalume Coating Chromate Conversion Coating Electrostatically Applied Thermally Bonded Polyester Powder Coating Minimum Film Thickness 2.5 Mils</p> <p>POSTS: 2" x 2" (51mm x 51mm) 16 Gauge Standard Post Spacing 97-1/8" (2466mm) OC.</p> <p>POST CAP: Pyramid, Ball or Spear</p> <p>RAILS: 1-1/4" x 1-1/4" (32mm x 32mm) 14 Gauge</p> <p>PICKETS: 5/8" x 5/8" (15mm x 15mm) 16 Gauge</p>	<p>FITTINGS: 15 Gauge Stamp Forged Factory Finish. As Above</p> <p>WELDS: Stainless Steel</p> <p>STANDARD PANEL WIDTH: 91-1/2" (2324mm)</p> <p>AVAILABLE PANEL HEIGHTS: 48" (1219mm) (plus cap if applicable) 60" (1524mm) 72" (1828mm)</p> <p>NOTE: Tamper Proof Nut Available For Brackets</p> <p>COLOURS: Standard - High Gloss Black Optional Colours - Brown, Forest Green & Matt Black Custom Colours Available Upon Request.</p>
---	---

The following note shall apply to all drawings and associated documents:
 1. Copyright of this drawing and design is reserved by the Designer & European Wrought Iron Works Ltd. The drawing and all associated documents are an instrument of service by the Designer & European Wrought Iron Works Ltd. The drawing and the information contained therein may not be reproduced in whole or in part without prior written or verbal permission of the designer or European Wrought Iron Works Ltd.
 2. Drawings are not to be scaled for construction. All existing site conditions and dimensions required to perform the work are to be verified and any discrepancies are to be reported to the designer & European Wrought Iron Works Ltd.
 3. These drawings are not to be used for construction unless noted below as "Issued for Construction"
 4. All work to be carried out in conformance with the Code and Bylaws of the authorities having jurisdiction.
 5. The Designer of these plans and specifications gives no warranty or representation to any party about the constructability of the item represented by them.

CONFIDENTIAL: NOT TO BE DISCLOSED OR REPRODUCED



ROYALTY COLLECTION
Crown

TITLE: **Royalty Collection**
Crown

TOLERANCES INCHES UNLESS OTHERWISE NOTED
 X.XXX" ±0.005"
 X.XX" ±0.05"
 X.X" ±0.25"
 FRACTIONAL ±1/16"
 ANGULAR ±1°

SCALE: NTS.
 DATE DRAWN: June 2015
 DRAWN BY: DCM

DO NOT MODIFY OR SCALE DRAWING

PROJECT TITLE:

DESIGN: P.D.
 SHEET NO: 11

DRAWING & DESIGN REMAIN THE PROPERTY OF EUROPEAN WROUGHT IRON WORKS LTD.

FINISH: Custom
 DRAWING NUMBER: RC-11
 REV: 1- A