

Specifications

POST, RAILS & PICKETS: Cold Formed Steel Tubing
Interior And Exterior Galvalume Coating
Chromate Conversion Coating
Electrostatically Applied
Thermally Bonded Polyester Powder Coating
Minimum Film Thickness 2.5 Mills

POSTS: 4" x 4" (100mm x 100mm)
.150 or .250 Wall

POST CAP: Pyramid, Ball or Spear

RAILS: 1-1/2" x 1-1/2" (38mm x 38mm) 14 Gauge

PICKETS: 1" x 1" (25mm x 25mm) 16 Gauge

FITTINGS: Stamp Forged Factory Finish. As Above

WELDS: Stainless Steel

STANDARD GATE WIDTH: 45-3/4" (1162mm)

AVAILABLE GATE HEIGHTS: 48" (1219mm)
(plus finial if applicable)

60" (1524mm)

72" (1828mm)

NOTE: Tamper Proof Nut Available For Brackets

COLOURS: Standard - High Gloss Black
Optional Colours - Brown, Forest Green & Matt Black

Custom Colours Available Upon Request.

The following note shall apply to all drawings and associated documents:

1. Copyright of this drawing and design is reserved by the Designer & European Wrought Iron Works Ltd.. The drawing and all associated documents are an instrument of service by the Designer & European Wrought Iron Works Ltd.. The drawing and the information contained therein may not be reproduced in whole or in part without prior written or verbal permission of the designer or European Wrought Iron Works Ltd..

2. Drawings are not to be scaled for construction. All existing site conditions and dimensions required to perform the work are to be verified and any discrepancies are to be reported to the designer & European Wrought Iron Works Ltd..

3. These drawings are not to be used for construction unless noted below as "Issued for Construction"

4. All work to be carried out in conformance with the Code and Bylaws of the authorities having jurisdiction.

5. The Designer of these plans and specifications gives no warranty or representation to any party about the constructability of the item represented by them.

CONFIDENTIAL: NOT TO BE DISCLOSED OR REPRODUCED

EUROPEAN
WROUGHT IRON WORKS

WITHOUT THE WRITTEN PERMISSION OF EUROPEAN WROUGHT IRON WORKS LTD.

TOLERANCES
INCHES
UNLESS OTHERWISE NOTED
X.XXX" ±0.005"
X.XX" ±0.05"
X.X" ±0.25"
FRACTIONAL ±1/16"
ANGULAR ±1°

DO NOT
MODIFY OR
SCALE DRAWING

DRAWING & DESIGN REMAIN THE PROPERTY OF EUROPEAN WROUGHT IRON WORKS LTD.

PROJECT TITLE:

TITLE: **European Collection**
Gates

SCALE: NTS.
DATE DRAWN: Feb 2009
DRAWN BY: DCM

DESIGN: P.D.
SHEET NO: 1

FINISH: Custom
DRAWING NUMBER: EWIW-G01

REV 1- A

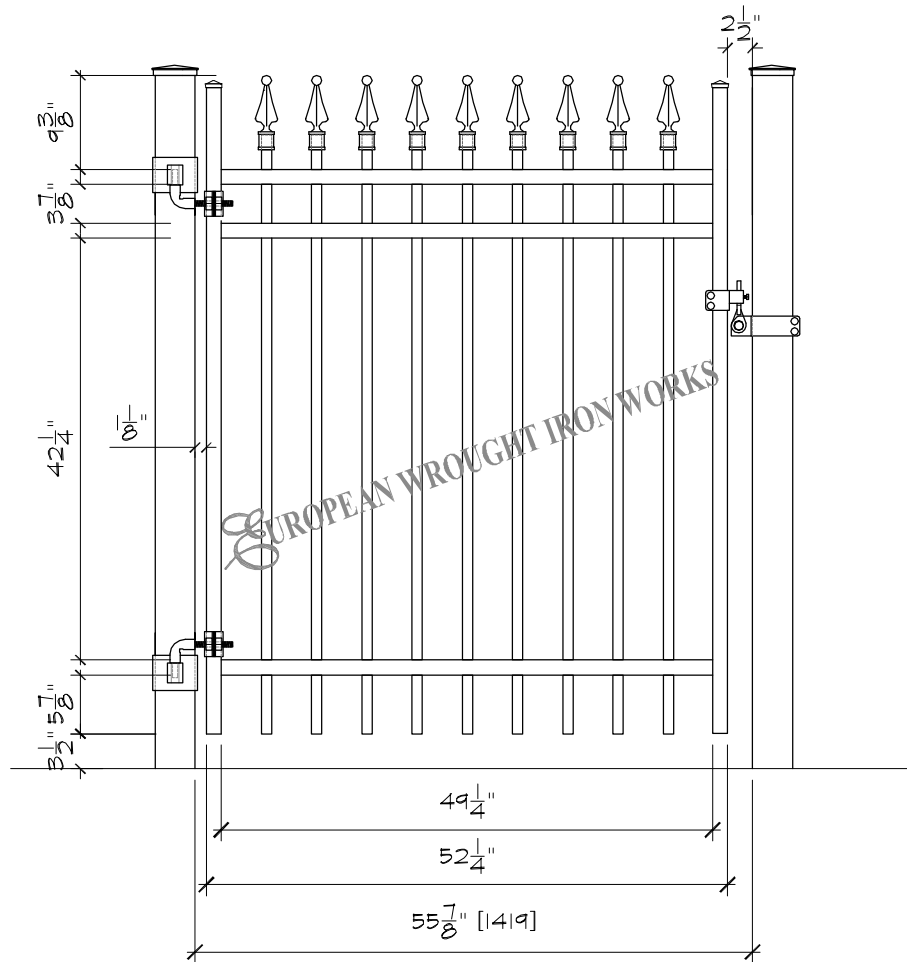

Specifications

POST, RAILS & PICKETS: Cold Formed Steel Tubing
Interior And Exterior Galvalume Coating
Chromate Conversion Coating
Electrostatically Applied
Thermally Bonded Polyester Powder Coating
Minimum Film Thickness 2.5 Mills

POSTS: 4" x 4" (100mm x 100mm)
.150 or .250 Wall

POST CAP: Pyramid, Ball or Spear

RAILS: 1-1/2" x 1-1/2" (38mm x 38mm) 14 Gauge

PICKETS: 1" x 1" (25mm x 25mm) 16 Gauge

FITTINGS: Stamp Forged Factory Finish. As Above

WELDS: Stainless Steel

STANDARD GATE WIDTH: 55-7/8" (1419mm)

AVAILABLE GATE HEIGHTS: 48" (1219mm)
(plus finial if applicable)
60" (1524mm)
72" (1828mm)

NOTE: Tamper Proof Nut Available For Brackets

COLOURS: Standard - High Gloss Black
Optional Colours - Brown, Forest Green & Matt Black

Custom Colours Available Upon Request.

The following note shall apply to all drawings and associated documents:

- Copyright of this drawing and design is reserved by the Designer & European Wrought Iron Works Ltd. The drawing and all associated documents are an instrument of service by the Designer & European Wrought Iron Works Ltd. The drawing and the information contained therein may not be reproduced in whole or in part without written or verbal permission of the designer or European Wrought Iron Works Ltd.
- Drawings are not to be scaled for construction. All existing site conditions and dimensions required to perform the work are to be verified and any discrepancies are to be reported to the designer & European Wrought Iron Works Ltd.
- These drawings are not to be used for construction unless noted below as "Issued for Construction"
- All work to be carried out in conformance with the Code and Bylaws of the authorities having jurisdiction.
- The Designer of these plans and specifications gives no warranty or representation to any party about the constructability of the item represented by them.

CONFIDENTIAL: NOT TO BE DISCLOSED OR REPRODUCED

EUROPEAN
WROUGHT IRON WORKS

TITLE: **European Collection**
Gates

TOLERANCES
INCHES
UNLESS OTHERWISE NOTED
X.XXX" ±0.005"
X.XX" ±0.05"
X.X" ±0.25"
FRACTIONAL ±1/16"
ANGULAR ±1°

SCALE: NTS.
DATE DRAWN: Feb 2009
DRAWN BY: DCM

DO NOT
MODIFY OR
SCALE DRAWING

DRAWING & DESIGN REMAIN THE PROPERTY OF EUROPEAN WROUGHT IRON WORKS LTD.

PROJECT TITLE:

DESIGN: P.D.
SHEET NO: 1

FINISH: Custom
DRAWING NUMBER: EWIW-G02

REV 1- A

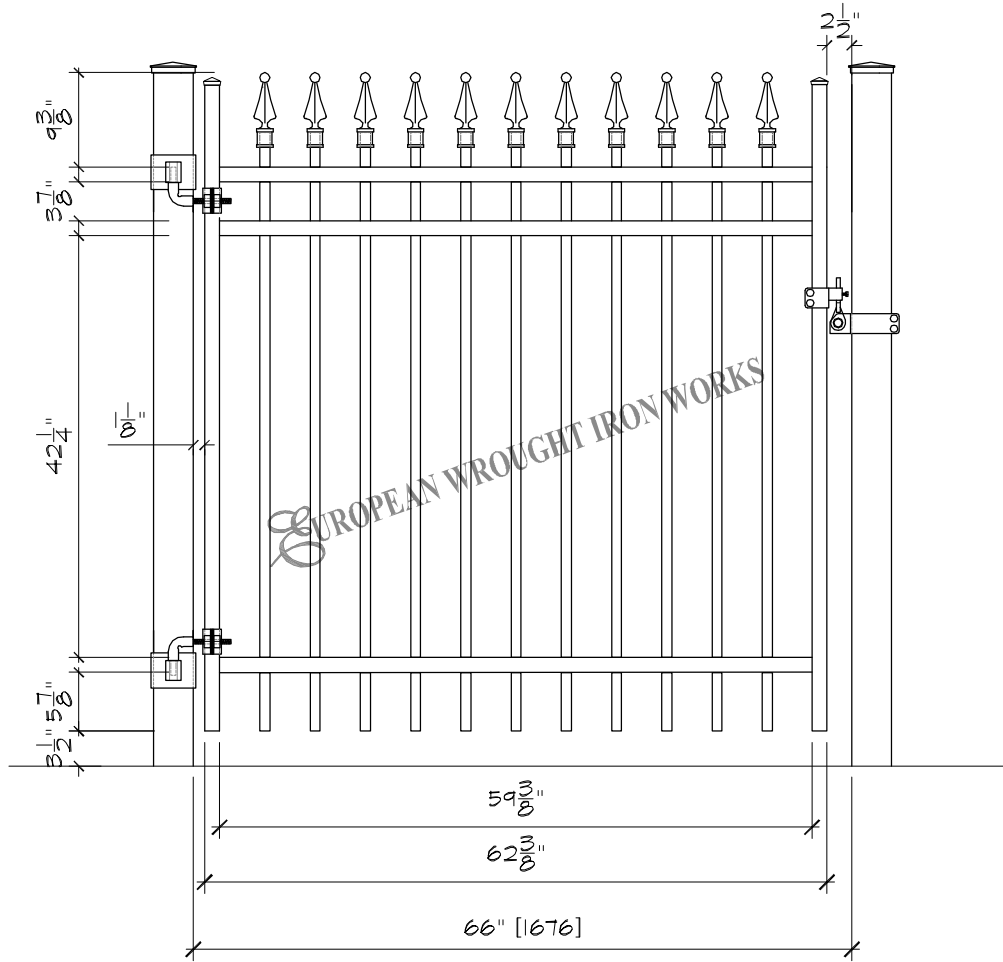

Specifications

POST, RAILS & PICKETS: Cold Formed Steel Tubing
Interior And Exterior Galvalume Coating
Chromate Conversion Coating
Electrostatically Applied
Thermally Bonded Polyester Powder Coating
Minimum Film Thickness 2.5 Mils

POSTS: 4" x 4" (100mm x 100mm)
.150 or .250 Wall

POST CAP: Pyramid, Ball or Spear

RAILS: 1-1/2" x 1-1/2" (38mm x 38mm) 14 Gauge

PICKETS: 1" x 1" (25mm x 25mm) 16 Gauge

FITTINGS: Stamp Forged Factory Finish. As Above

WELDS: Stainless Steel

STANDARD GATE WIDTH: 66" (1676mm)

AVAILABLE GATE HEIGHTS: 48" (1219mm)
(plus finial if applicable)
60" (1524mm)
72" (1828mm)

NOTE: Tamper Proof Nut Available For Brackets

COLOURS: Standard - High Gloss Black
Optional Colours - Brown, Forest Green & Matt Black

Custom Colours Available Upon Request.

The following note shall apply to all drawings and associated documents:

- Copyright of this drawing and design is reserved by the Designer & European Wrought Iron Works Ltd.. The drawing and all associated documents are an instrument of service by the Designer & European Wrought Iron Works Ltd.. The drawing and the information contained therein may not be reproduced in whole or in part without prior written or verbal permission of the designer or European Wrought Iron Works Ltd..
- Drawings are not to be scaled for construction. All existing site conditions and dimensions required to perform the work are to be verified and any discrepancies are to be reported to the designer & European Wrought Iron Works Ltd..
- These drawings are not to be used for construction unless noted below as "Issued for Construction"
- All work to be carried out in conformance with the Code and Bylaws of the authorities having jurisdiction.
- The Designer of these plans and specifications gives no warranty or representation to any party about the constructability of the item represented by them.

CONFIDENTIAL: NOT TO BE DISCLOSED OR REPRODUCED

EUROPEAN
WROUGHT IRON WORKS
WITHOUT THE WRITTEN PERMISSION OF EUROPEAN WROUGHT IRON WORKS LTD.

TITLE:
European Collection
Gates

TOLERANCES
INCHES
UNLESS OTHERWISE NOTED
X.XXX" ±0.005"
X.XX" ±0.05"
X.X" ±0.25"
FRACTIONAL ±1/16"
ANGULAR ±1°

SCALE: NTS.
DATE DRAWN: Feb 2009
DRAWN BY: DCM

DO NOT
MODIFY OR
SCALE DRAWING

PROJECT TITLE:

DRAWING & DESIGN REMAIN THE PROPERTY OF EUROPEAN WROUGHT IRON WORKS LTD.

DESIGN: P.D.
SHEET NO: 1

FINISH: Custom
DRAWING NUMBER: EWIW-G03

REV 1- A

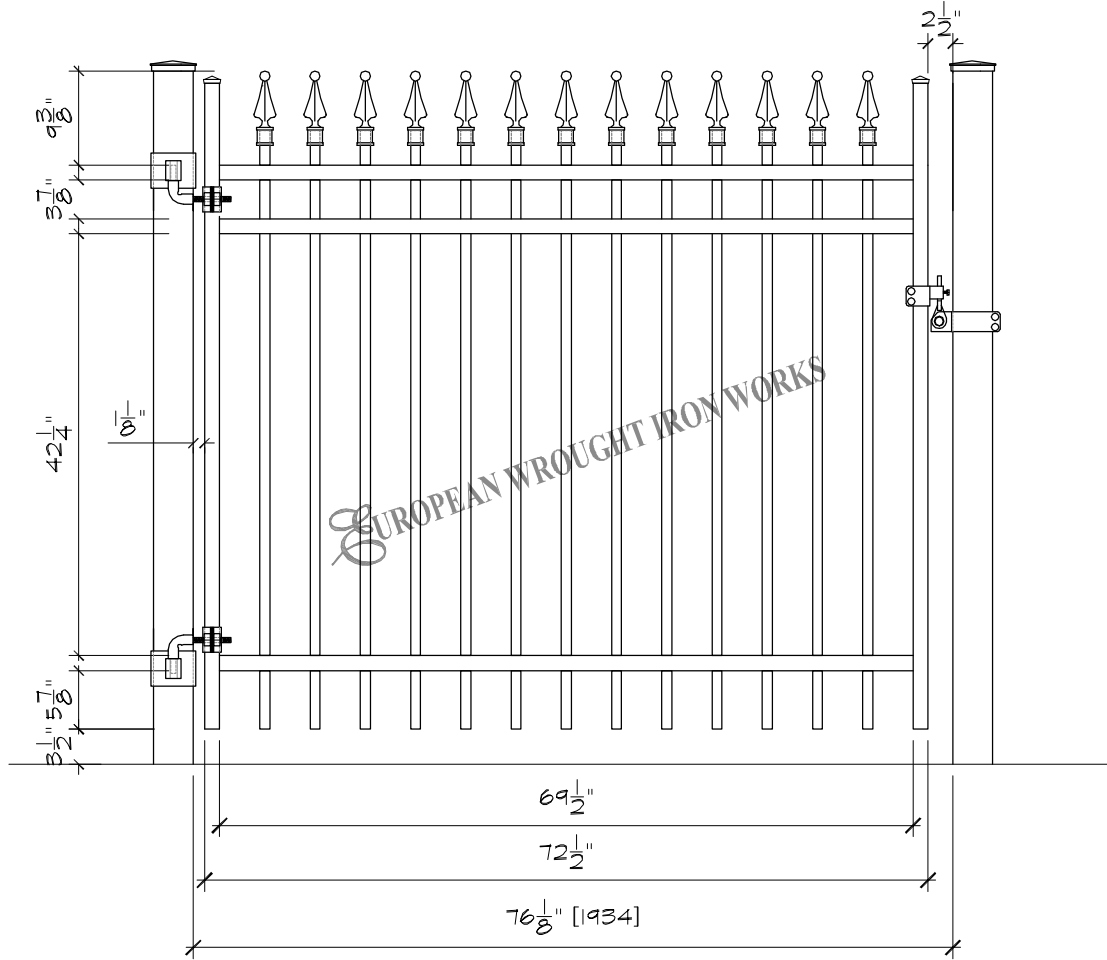

Specifications

POST, RAILS & PICKETS: Cold Formed Steel Tubing
Interior And Exterior Galvalume Coating
Chromate Conversion Coating
Electrostatically Applied
Thermally Bonded Polyester Powder Coating
Minimum Film Thickness 2.5 Mils

POSTS: 4" x 4" (100mm x 100mm)
.150 or .250 Wall

POST CAP: Pyramid, Ball or Spear

RAILS: 1-1/2" x 1-1/2" (38mm x 38mm) 14 Gauge

PICKETS: 1" x 1" (25mm x 25mm) 16 Gauge

FITTINGS: Stamp Forged Factory Finish. As Above

WELDS: Stainless Steel

STANDARD GATE WIDTH: 76-1/8" (1934mm)

AVAILABLE GATE HEIGHTS: 48" (1219mm)
(plus finial if applicable)
60" (1524mm)
72" (1828mm)

NOTE: Tamper Proof Nut Available For Brackets

COLOURS: Standard - High Gloss Black
Optional Colours - Brown, Forest Green & Matt Black

Custom Colours Available Upon Request.

The following note shall apply to all drawings and associated documents:

1. Copyright of this drawing and design is reserved by the Designer & European Wrought Iron Works Ltd.. The drawing and all associated documents are an instrument of service by the Designer & European Wrought Iron Works Ltd.. The drawing and the information contained therein may not be reproduced in whole or in part without prior written or verbal permission of the designer or European Wrought Iron Works Ltd..

2. Drawings are not to be scaled for construction. All existing site conditions and dimensions required to perform the work are to be verified and any discrepancies are to be reported to the designer & European Wrought Iron Works Ltd..

3. These drawings are not to be used for construction unless noted below as "Issued for Construction"

4. All work to be carried out in conformance with the Code and Bylaws of the authorities having jurisdiction.

5. The Designer of these plans and specifications gives no warranty or representation to any party about the constructability of the item represented by them.

CONFIDENTIAL: NOT TO BE DISCLOSED OR REPRODUCED



European Collection
Gates

TOLERANCES
INCHES
UNLESS OTHERWISE NOTED
X.XXX" ±0.005"
X.XX" ±0.05"
X.X" ±0.25"
FRACTIONAL ±1/16"
ANGULAR ±1°

SCALE: NTS.
DATE DRAWN: Feb 2009
DRAWN BY: DCM

DO NOT
MODIFY OR
SCALE DRAWING

PROJECT TITLE:

DESIGN: P.D.
SHEET NO: 1

DRAWING & DESIGN REMAIN THE PROPERTY OF EUROPEAN WROUGHT IRON WORKS LTD.

FINISH: Custom
DRAWING NUMBER: EWIW-G04
REV 1- A

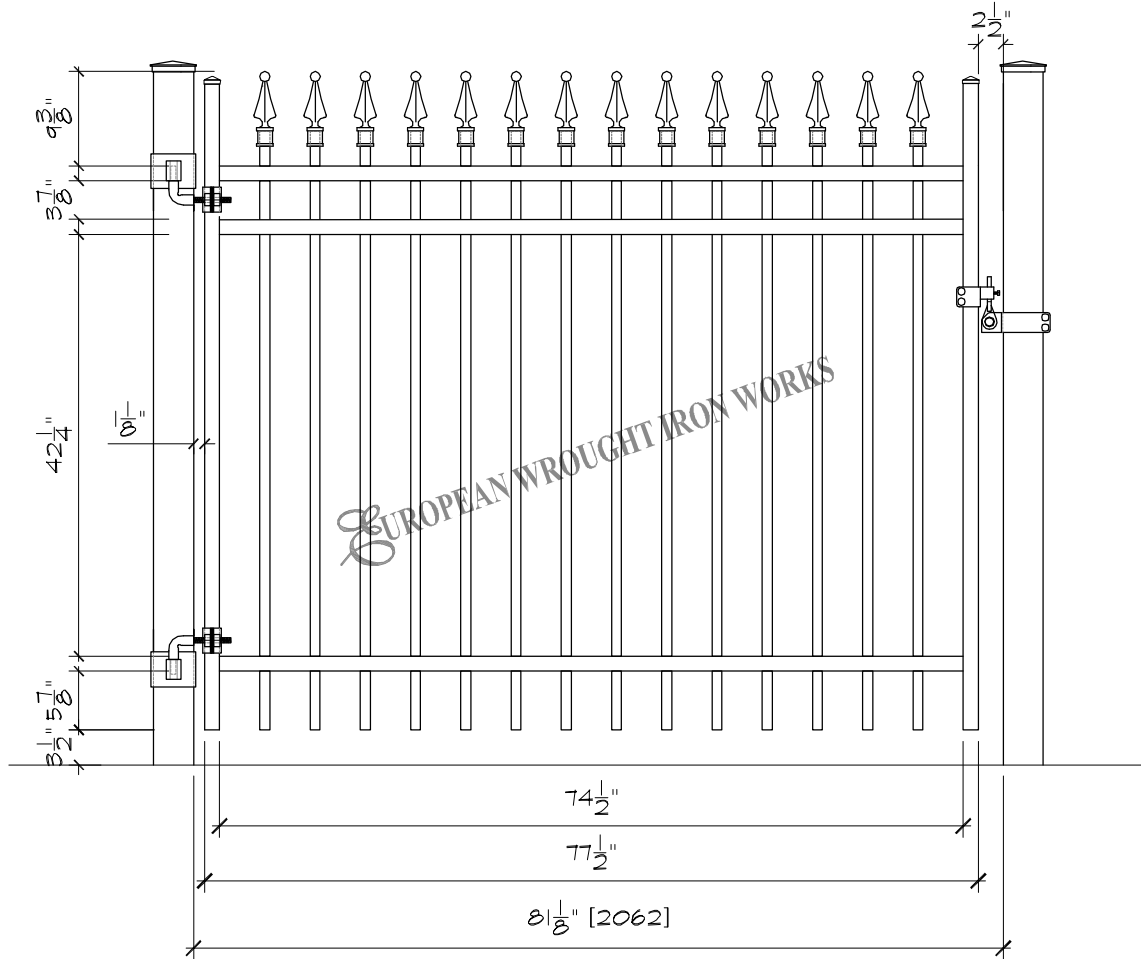

Specifications

POST, RAILS & PICKETS: Cold Formed Steel Tubing
Interior And Exterior Galvalume Coating
Chromate Conversion Coating
Electrostatically Applied
Thermally Bonded Polyester Powder Coating
Minimum Film Thickness 2.5 Mils

POSTS: 4" x 4" (100mm x 100mm)
.150 or .250 Wall

POST CAP: Pyramid, Ball or Spear

RAILS: 1-1/2" x 1-1/2" (38mm x 38mm) 14 Gauge

PICKETS: 1" x 1" (25mm x 25mm) 16 Gauge

FITTINGS: Stamp Forged Factory Finish. As Above

WELDS: Stainless Steel

STANDARD GATE WIDTH: 81-1/8" (2062mm)

AVAILABLE GATE HEIGHTS: 48" (1219mm)
(plus finial if applicable)
60" (1524mm)
72" (1828mm)

NOTE: Tamper Proof Nut Available For Brackets

COLOURS: Standard - High Gloss Black
Optional Colours - Brown, Forest Green & Matt Black

Custom Colours Available Upon Request.

The following note shall apply to all drawings and associated documents:

1. Copyright of this drawing and design is reserved by the Designer & European Wrought Iron Works Ltd.. The drawing and all associated documents are an instrument of service by the Designer & European Wrought Iron Works Ltd.. The drawing and the information contained therein may not be reproduced in whole or in part without prior written or verbal permission of the designer or European Wrought Iron Works Ltd..

2. Drawings are not to be scaled for construction. All existing site conditions and dimensions required to perform the work are to be verified and any discrepancies are to be reported to the designer & European Wrought Iron Works Ltd..

3. These drawings are not to be used for construction unless noted below as "Issued for Construction"

4. All work to be carried out in conformance with the Code and Bylaws of the authorities having jurisdiction.

5. The Designer of these plans and specifications gives no warranty or representation to any party about the constructability of the item represented by them.

CONFIDENTIAL: NOT TO BE DISCLOSED OR REPRODUCED

EUROPEAN
WROUGHT IRON WORKS

TITLE: **European Collection**
Gates

TOLERANCES
INCHES
UNLESS OTHERWISE NOTED
X.XXX" ±0.005"
X.XX" ±0.05"
X.X" ±0.25"
FRACTIONAL ±1/16"
ANGULAR ±1°

SCALE: NTS.
DATE DRAWN: Feb 2009
DRAWN BY: DCM

DO NOT
MODIFY OR
SCALE DRAWING

PROJECT TITLE:

DRAWING & DESIGN REMAIN THE PROPERTY OF EUROPEAN WROUGHT IRON WORKS LTD.

DESIGN: P.D.

SHEET NO: 1

FINISH: Custom

DRAWING NUMBER: EWIW-G05

REV 1-

A

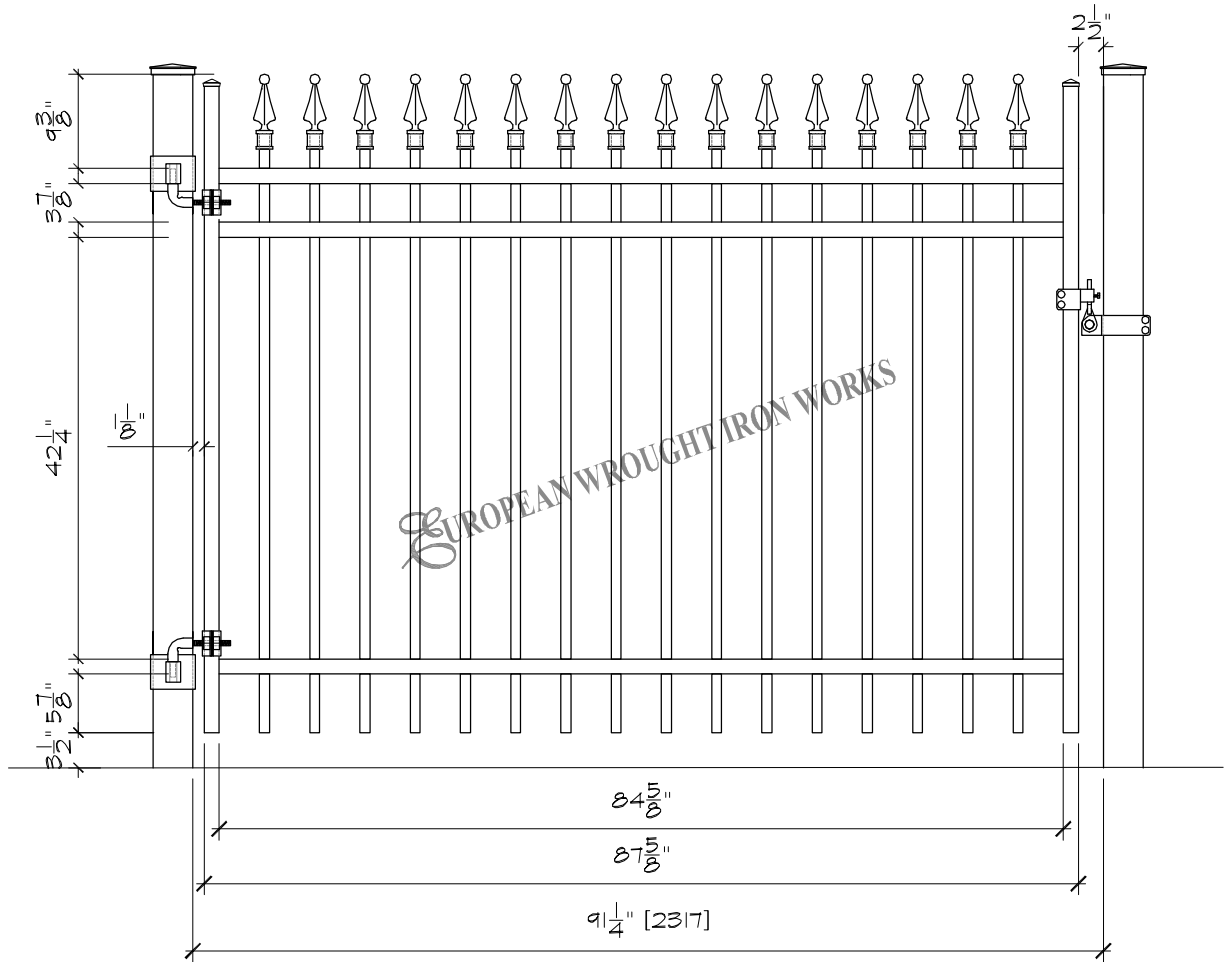

Specifications

POST, RAILS & PICKETS: Cold Formed Steel Tubing
Interior And Exterior Galvalume Coating
Chromate Conversion Coating
Electrostatically Applied
Thermally Bonded Polyester Powder Coating
Minimum Film Thickness 2.5 Mils

POSTS: 4" x 4" (100mm x 100mm)
.150 or .250 Wall

POST CAP: Pyramid, Ball or Spear

RAILS: 1-1/2" x 1-1/2" (38mm x 38mm) 14 Gauge

PICKETS: 1" x 1" (25mm x 25mm) 16 Gauge

FITTINGS: Stamp Forged Factory Finish. As Above

WELDS: Stainless Steel

STANDARD GATE WIDTH: 91-1/4" (2317mm)

AVAILABLE GATE HEIGHTS: 48" (1219mm)
(plus finial if applicable)
60" (1524mm)
72" (1828mm)

NOTE: Tamper Proof Nut Available For Brackets

COLOURS: Standard - High Gloss Black
Optional Colours - Brown, Forest Green & Matt Black

Custom Colours Available Upon Request.

The following note shall apply to all drawings and associated documents:

- Copyright of this drawing and design is reserved by the Designer & European Wrought Iron Works Ltd. The drawing and all associated documents are an instrument of service by the Designer & European Wrought Iron Works Ltd. The drawing and the information contained therein may not be reproduced in whole or in part without prior written or verbal permission of the designer or European Wrought Iron Works Ltd.
- Drawings are not to be scaled for construction. All existing site conditions and dimensions required to perform the work are to be verified and any discrepancies are to be reported to the designer & European Wrought Iron Works Ltd.
- These drawings are not to be used for construction unless noted below as "Issued for Construction"
- All work to be carried out in conformance with the Code and Bylaws of the authorities having jurisdiction.
- The Designer of these plans and specifications gives no warranty or representation to any party about the constructability of the item represented by them.

CONFIDENTIAL: NOT TO BE DISCLOSED OR REPRODUCED

EUROPEAN
WROUGHT IRON WORKS

TITLE:
European Collection
Gates

TOLERANCES
INCHES
UNLESS OTHERWISE NOTED
X.XXX" ±0.005"
X.XX" ±0.05"
X.X" ±0.25"
FRACTIONAL ±1/16"
ANGULAR ±1°

SCALE: NTS.
DATE DRAWN: Feb 2009
DRAWN BY: DCM

DO NOT
MODIFY OR
SCALE DRAWING

DRAWING & DESIGN REMAIN THE PROPERTY OF EUROPEAN WROUGHT IRON WORKS LTD.

PROJECT TITLE:

DESIGN: P.D.
SHEET NO: 1

FINISH: Custom
DRAWING NUMBER: EWIW-G06

REV 1- A

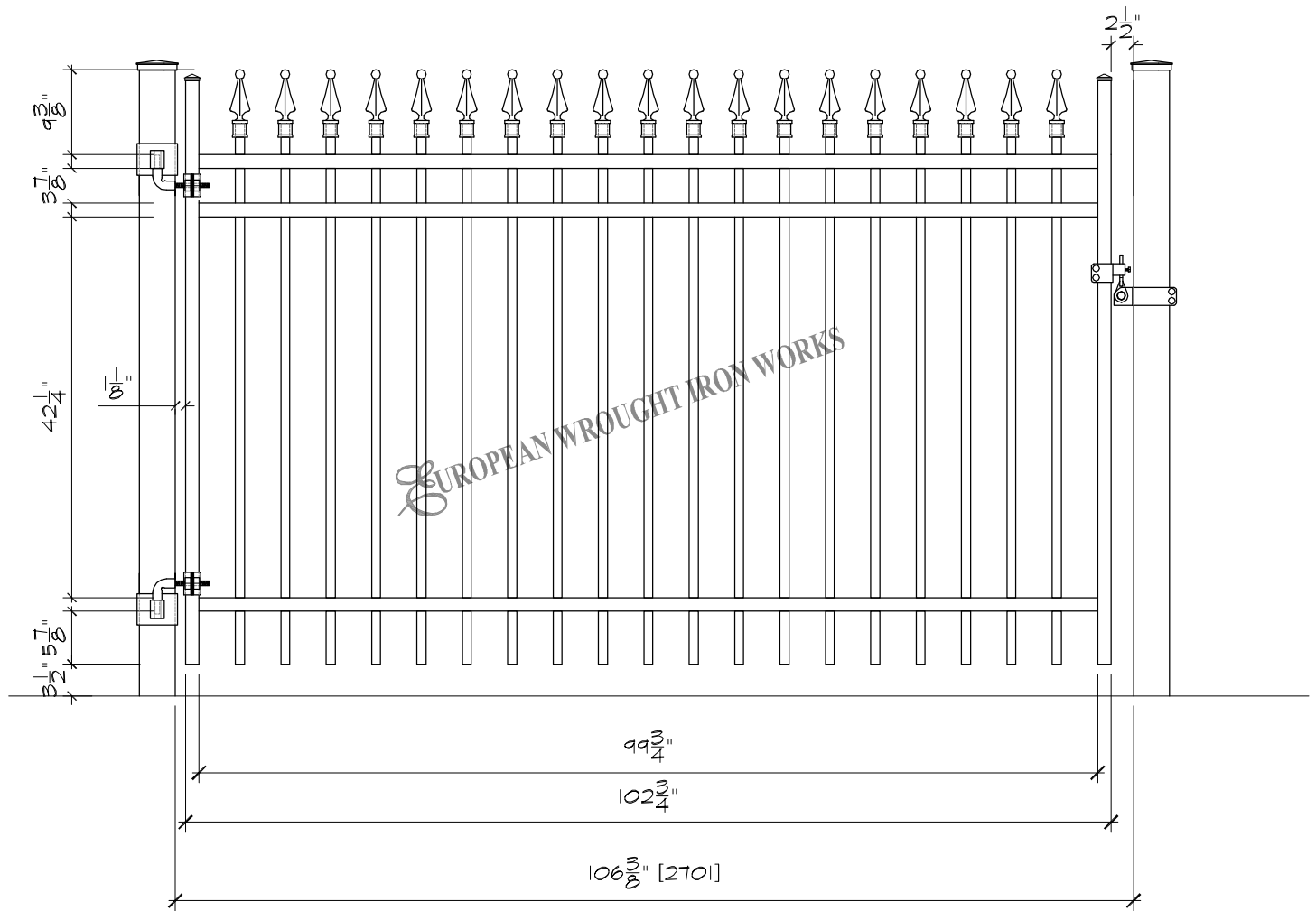

Specifications

POST, RAILS & PICKETS: Cold Formed Steel Tubing
Interior And Exterior Galvalume Coating
Chromate Conversion Coating
Electrostatically Applied
Thermally Bonded Polyester Powder Coating
Minimum Film Thickness 2.5 Mils

POSTS: 4" x 4" (100mm x 100mm)
.150 or .250 Wall

POST CAP: Pyramid, Ball or Spear

RAILS: 1-1/2" x 1-1/2" (38mm x 38mm) 14 Gauge

PICKETS: 1" x 1" (25mm x 25mm) 16 Gauge

FITTINGS: Stamp Forged Factory Finish. As Above

WELDS: Stainless Steel

STANDARD GATE WIDTH: 106-3/8" (2701mm)

AVAILABLE GATE HEIGHTS: 48" (1219mm)
(plus finial if applicable)
60" (1524mm)
72" (1828mm)

NOTE: Tamper Proof Nut Available For Brackets

COLOURS: Standard - High Gloss Black
Optional Colours - Brown, Forest Green & Matt Black

Custom Colours Available Upon Request.

The following note shall apply to all drawings and associated documents:

1. Copyright of this drawing and design is reserved by the Designer & European Wrought Iron Works Ltd.. The drawing and all associated documents are an instrument of service by the Designer & European Wrought Iron Works Ltd.. The drawing and the information contained therein may not be reproduced in whole or in part without prior written or verbal permission of the designer or European Wrought Iron Works Ltd..

2. Drawings are not to be scaled for construction. All existing site conditions and dimensions required to perform the work are to be verified and any discrepancies are to be reported to the designer & European Wrought Iron Works Ltd..

3. These drawings are not to be used for construction unless noted below as "Issued for Construction"

4. All work to be carried out in conformance with the Code and Bylaws of the authorities having jurisdiction.

5. The Designer of these plans and specifications gives no warranty or representation to any party about the constructability of the item represented by them.

CONFIDENTIAL: NOT TO BE DISCLOSED OR REPRODUCED

EUROPEAN
WROUGHT IRON WORKS

TITLE: **European Collection**
Gates

TOLERANCES
INCHES
UNLESS OTHERWISE NOTED
X.XXX" ±0.005"
X.XX" ±0.05"
X.X" ±0.25"
FRACTIONAL ±1/16"
ANGULAR ±1°

SCALE: NTS.
DATE DRAWN: Feb 2009
DRAWN BY: DCM

DO NOT
MODIFY OR
SCALE DRAWING

PROJECT TITLE:

DRAWING & DESIGN REMAIN THE PROPERTY OF EUROPEAN WROUGHT IRON WORKS LTD.

DESIGN: P.D.

SHEET NO: 1

FINISH: Custom

DRAWING NUMBER: EWIW-G07

REV 1-

A

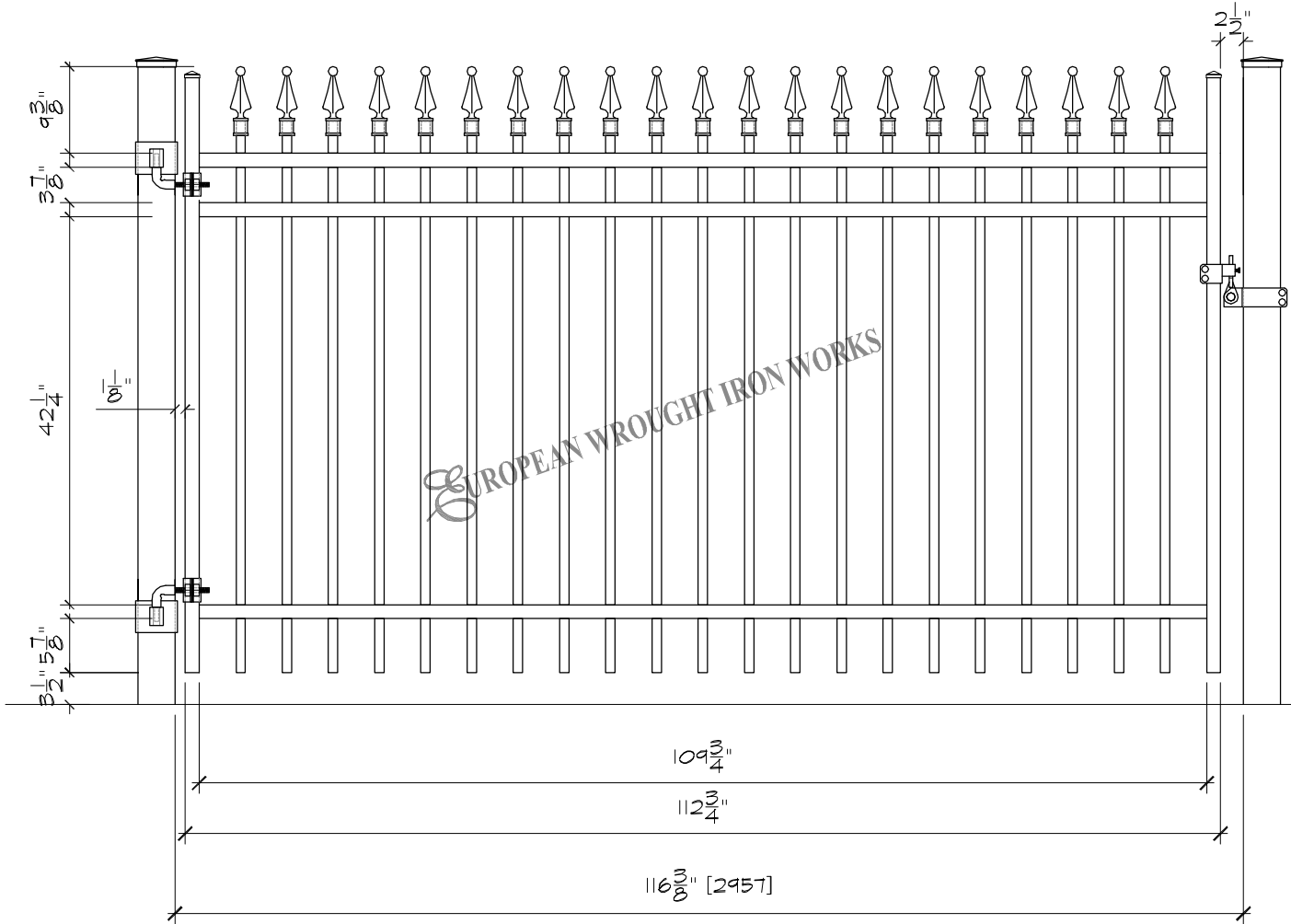

Specifications

POST, RAILS & PICKETS: Cold Formed Steel Tubing
Interior And Exterior Galvalume Coating
Chromate Conversion Coating
Electrostatically Applied
Thermally Bonded Polyester Powder Coating
Minimum Film Thickness 2.5 Mils

POSTS: 4" x 4" (100mm x 100mm)
.150 or .250 Wall

POST CAP: Pyramid, Ball or Spear

RAILS: 1-1/2" x 1-1/2" (38mm x 38mm) 14 Gauge

PICKETS: 1" x 1" (25mm x 25mm) 16 Gauge

FITTINGS: Stamp Forged Factory Finish. As Above

WELDS: Stainless Steel

STANDARD GATE WIDTH: 116-3/8" (2957mm)

AVAILABLE GATE HEIGHTS: 48" (1219mm)
(plus finial if applicable)
60" (1524mm)
72" (1828mm)

NOTE: Tamper Proof Nut Available For Brackets

COLOURS: Standard - High Gloss Black
Optional Colours - Brown, Forest Green & Matt Black

Custom Colours Available Upon Request.

The following note shall apply to all drawings and associated documents:

- Copyright of this drawing and design is reserved by the Designer & European Wrought Iron Works Ltd.. The drawing and all associated documents are an instrument of service by the Designer & European Wrought Iron Works Ltd.. The drawing and the information contained therein may not be reproduced in whole or in part without prior written or verbal permission of the designer or European Wrought Iron Works Ltd..
- Drawings are not to be scaled for construction. All existing site conditions and dimensions required to perform the work are to be verified and any discrepancies are to be reported to the designer & European Wrought Iron Works Ltd..
- These drawings are not to be used for construction unless noted below as "Issued for Construction"
- All work to be carried out in conformance with the Code and Bylaws of the authorities having jurisdiction.
- The Designer of these plans and specifications gives no warranty or representation to any party about the constructability of the item represented by them.

CONFIDENTIAL: NOT TO BE DISCLOSED OR REPRODUCED

EUROPEAN
WROUGHT IRON WORKS

TITLE: **European Collection**
Gates

TOLERANCES
INCHES
UNLESS OTHERWISE NOTED
X.XXX" ±0.005"
X.XX" ±0.05"
X.X" ±0.25"
FRACTIONAL ±1/16"
ANGULAR ±1°

SCALE: NTS.
DATE DRAWN: Feb 2009
DRAWN BY: DCM

DO NOT
MODIFY OR
SCALE DRAWING

DRAWING & DESIGN REMAIN THE PROPERTY OF EUROPEAN WROUGHT IRON WORKS LTD.

PROJECT TITLE:

DESIGN: P.D.
SHEET NO: 1

FINISH: Custom
DRAWING NUMBER: EWIW-G08

REV 1- A

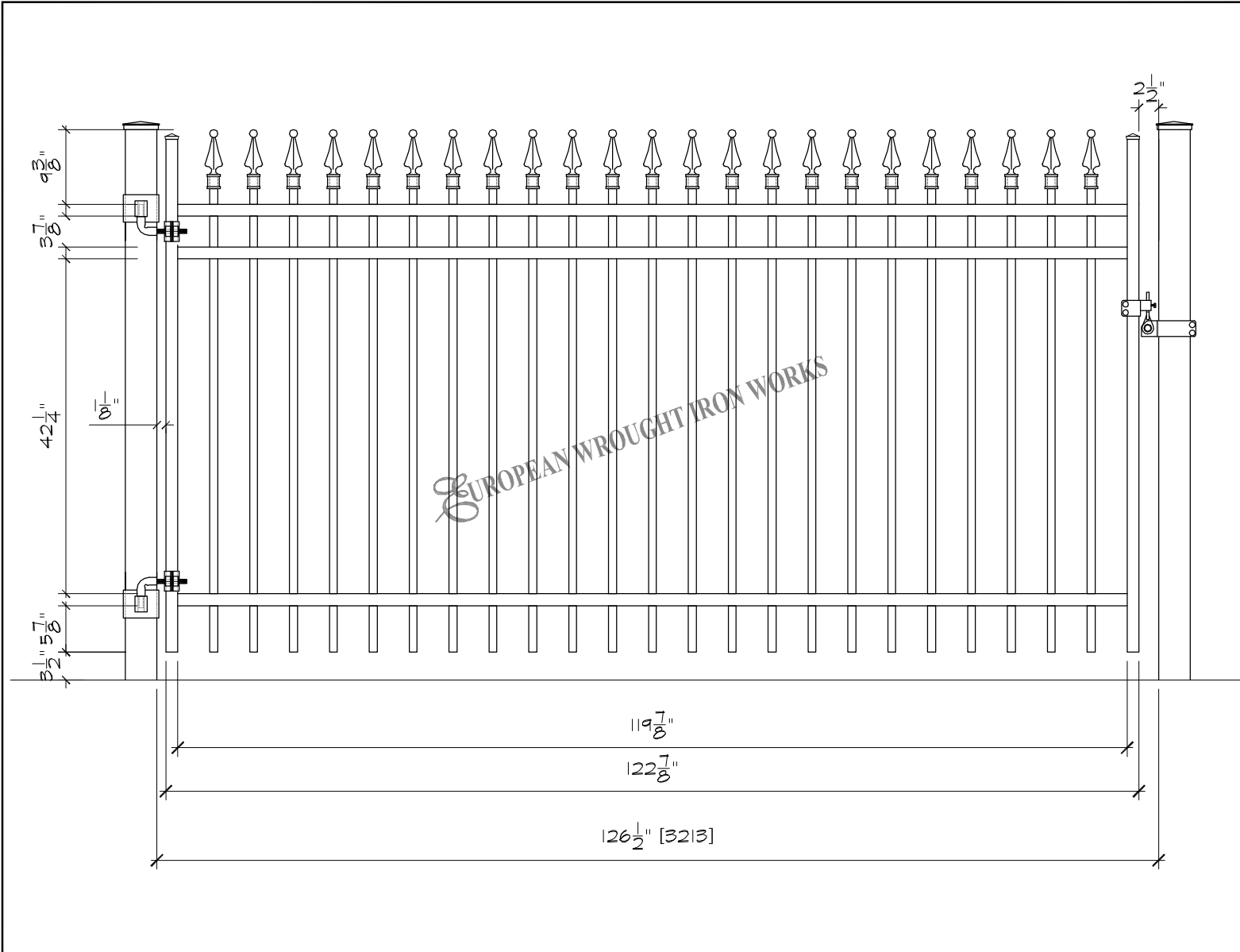

Specifications

POST, RAILS & PICKETS: Cold Formed Steel Tubing
Interior And Exterior Galvalume Coating
Chromate Conversion Coating
Electrostatically Applied
Thermally Bonded Polyester Powder Coating
Minimum Film Thickness 2.5 Mils

POSTS: 4" x 4" (100mm x 100mm)
.150 or .250 Wall

POST CAP: Pyramid, Ball or Spear

RAILS: 1-1/2" x 1-1/2" (38mm x 38mm) 14 Gauge

PICKETS: 1" x 1" (25mm x 25mm) 16 Gauge

FITTINGS: Stamp Forged Factory Finish. As Above

WELDS: Stainless Steel

STANDARD GATE WIDTH: 126-1/2" (3213mm)

AVAILABLE GATE HEIGHTS: 48" (1219mm)
(plus finial if applicable)
60" (1524mm)
72" (1828mm)

NOTE: Tamper Proof Nut Available For Brackets

COLOURS: Standard - High Gloss Black
Optional Colours - Brown, Forest Green & Matt Black

Custom Colours Available Upon Request.

The following note shall apply to all drawings and associated documents:
1. Copyright of this drawing and design is reserved by the Designer & European Wrought Iron Works Ltd.. The drawing and all associated documents are an instrument of service by the Designer & European Wrought Iron Works Ltd.. The drawing and the information contained therein may not be reproduced in whole or in part without prior written or verbal permission of the designer or European Wrought Iron Works Ltd..
2. Drawings are not to be scaled for construction. All existing site conditions and dimensions required to perform the work are to be verified and any discrepancies are to be reported to the designer & European Wrought Iron Works Ltd..
3. These drawings are not to be used for construction unless noted below as "Issued for Construction"
4. All work to be carried out in conformance with the Code and Bylaws of the authorities having jurisdiction.
5. The Designer of these plans and specifications gives no warranty or representation to any party about the constructability of the item represented by them.

CONFIDENTIAL: NOT TO BE DISCLOSED OR REPRODUCED

WITHOUT THE WRITTEN PERMISSION OF EUROPEAN WROUGHT IRON WORKS LTD.

TITLE: **European Collection Gates**

TOLERANCES INCHES UNLESS OTHERWISE NOTED
X.XXX" ±0.005"
X.XX" ±0.05"
X.X" ±0.25"
FRACTIONAL ±1/16"
ANGULAR ±1°

SCALE: NTS.
DATE DRAWN: Feb 2009
DRAWN BY: DCM

DO NOT MODIFY OR SCALE DRAWING

PROJECT TITLE:

DESIGN: P.D.
SHEET NO: 1

DRAWING & DESIGN REMAIN THE PROPERTY OF EUROPEAN WROUGHT IRON WORKS LTD.

FINISH: Custom
DRAWING NUMBER: EWIW-G09
REV: 1- A

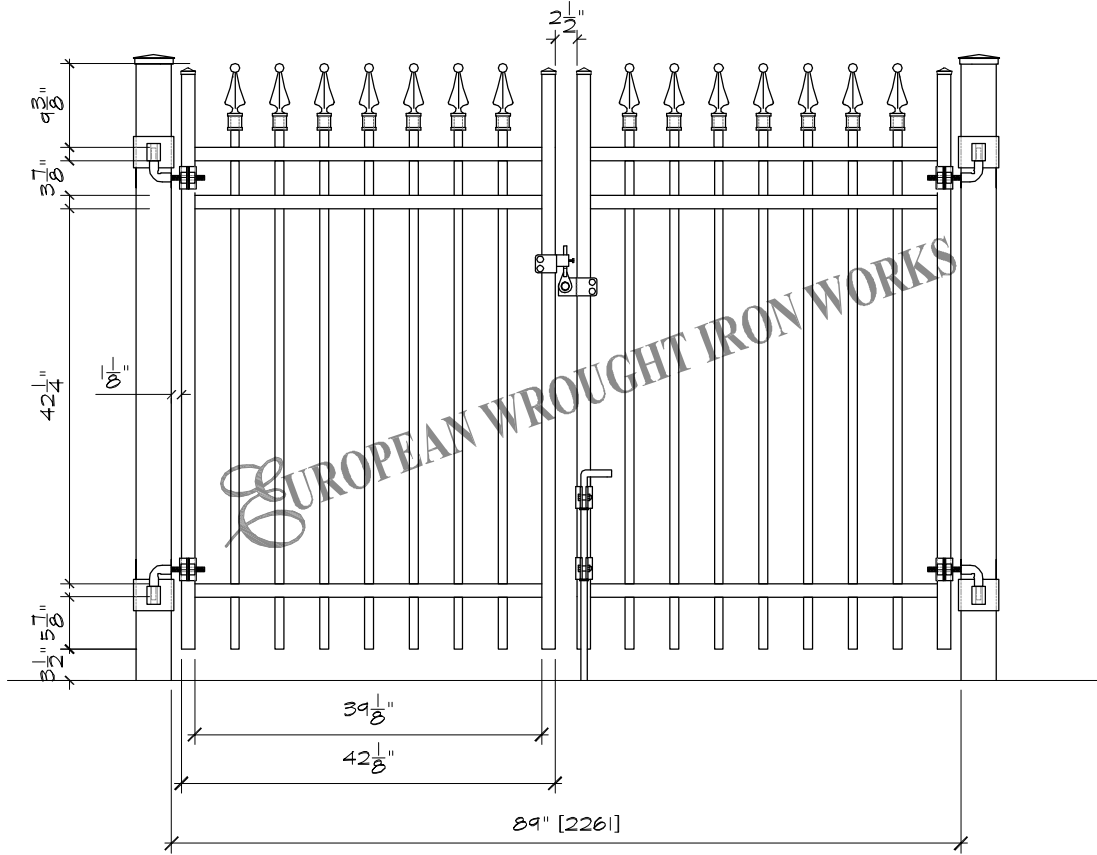

CORRECT

Specifications

POST, RAILS & PICKETS: Cold Formed Steel Tubing
Interior And Exterior Galvalume Coating
Chromate Conversion Coating
Electrostatically Applied
Thermally Bonded Polyester Powder Coating
Minimum Film Thickness 2.5 Mils

POSTS: 4" x 4" (100mm x 100mm)
.150 or .250 Wall

POST CAP: Pyramid, Ball or Spear

RAILS: 1-1/2" x 1-1/2" (38mm x 38mm) 14 Gauge

PICKETS: 1" x 1" (25mm x 25mm) 16 Gauge

FITTINGS: Stamp Forged Factory Finish. As Above

WELDS: Stainless Steel

STANDARD GATE WIDTH: 89" (2261mm)

AVAILABLE GATE HEIGHTS: 48" (1219mm)
(plus finial if applicable)
60" (1524mm)
72" (1828mm)

NOTE: Tamper Proof Nut Available For Brackets

COLOURS: Standard - High Gloss Black
Optional Colours - Brown, Forest Green & Matt Black

Custom Colours Available Upon Request.

The following note shall apply to all drawings and associated documents:
1. Copyright of this drawing and design is reserved by the Designer & European Wrought Iron Works Ltd. The drawing and all associated documents are an instrument of service by the Designer & European Wrought Iron Works Ltd. The drawing and the information contained therein may not be reproduced in whole or in part without prior written or verbal permission of the designer or European Wrought Iron Works Ltd.
2. Drawings are not to be scaled for construction. All existing site conditions and dimensions required to perform the work are to be verified and any discrepancies are to be reported to the designer & European Wrought Iron Works Ltd.
3. These drawings are not to be used for construction unless noted below as "Issued for Construction"
4. All work to be carried out in conformance with the Code and Bylaws of the authorities having jurisdiction.
5. The Designer of these plans and specifications gives no warranty or representation to any party about the constructability of the item represented by them.

CONFIDENTIAL: NOT TO BE DISCLOSED OR REPRODUCED
EUROPEAN WROUGHT IRON WORKS
WITHOUT THE WRITTEN PERMISSION OF EUROPEAN WROUGHT IRON WORKS LTD.

TITLE: **European Collection Gates**

TOLERANCES INCHES UNLESS OTHERWISE NOTED
X.XXX" ±0.005"
X.XX" ±0.05"
X.X" ±0.25"
FRACTIONAL ±1/16"
ANGULAR ±1°

SCALE: NTS.
DATE DRAWN: Feb 2009
DRAWN BY: DCM

DO NOT MODIFY OR SCALE DRAWING

PROJECT TITLE:
DESIGN: P.D.
SHEET NO: 1

DRAWING & DESIGN REMAIN THE PROPERTY OF EUROPEAN WROUGHT IRON WORKS LTD.

FINISH: Custom
DRAWING NUMBER: EWIW-GD01
REV: 1- A

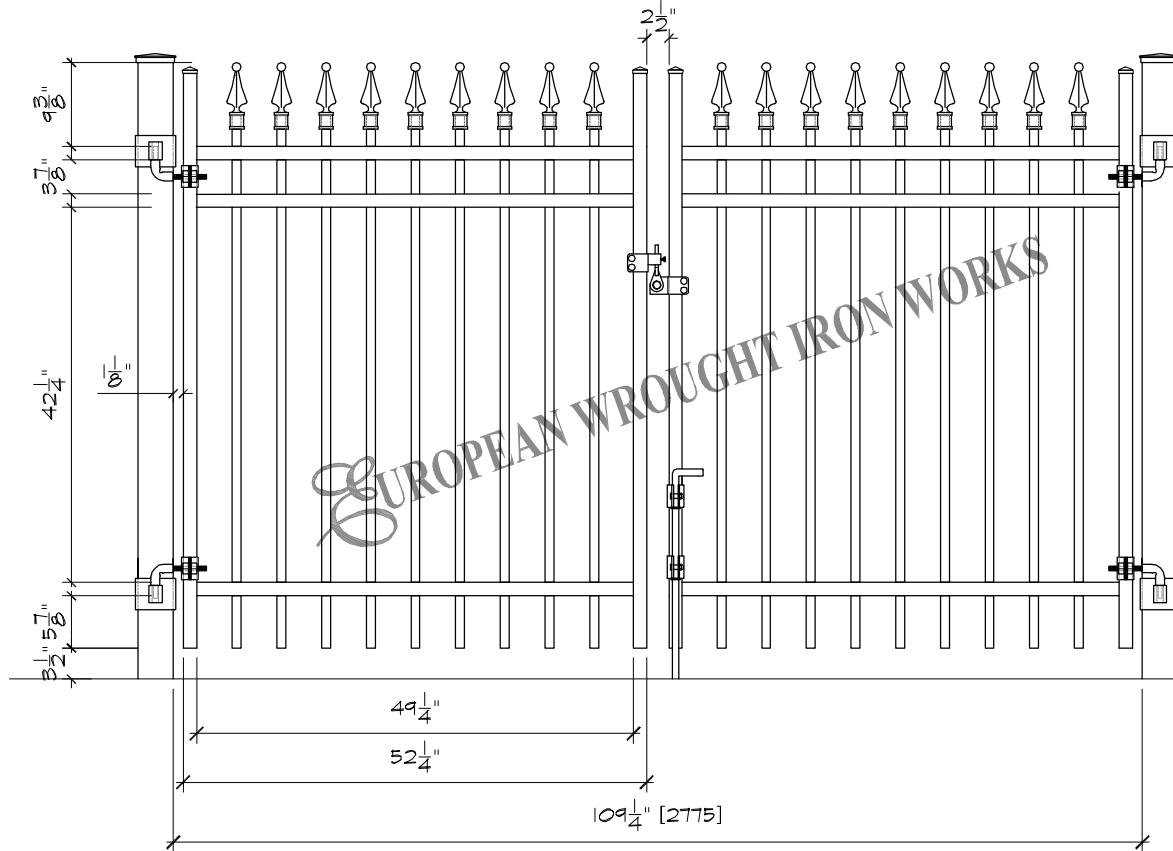

Specifications

POST, RAILS & PICKETS: Cold Formed Steel Tubing
Interior And Exterior Galvalume Coating
Chromate Conversion Coating
Electrostatically Applied
Thermally Bonded Polyester Powder Coating
Minimum Film Thickness 2.5 Mils

POSTS: 4" x 4" (100mm x 100mm)
.150 or .250 Wall

POST CAP: Pyramid, Ball or Spear

RAILS: 1-1/2" x 1-1/2" (38mm x 38mm) 14 Gauge

PICKETS: 1" x 1" (25mm x 25mm) 16 Gauge

FITTINGS: Stamp Forged Factory Finish. As Above

WELDS: Stainless Steel

STANDARD GATE WIDTH: 109-1/4" (2775mm)

AVAILABLE GATE HEIGHTS: 48" (1219mm)
(plus finial if applicable) 60" (1524mm)
72" (1828mm)

NOTE: Tamper Proof Nut Available For Brackets

COLOURS: Standard - High Gloss Black
Optional Colours - Brown, Forest Green & Matt Black

Custom Colours Available Upon Request.

The following note shall apply to all drawings and associated documents:
1. Copyright of this drawing and design is reserved by the Designer & European Wrought Iron Works Ltd.. The drawing and all associated documents are an instrument of service by the Designer & European Wrought Iron Works Ltd.. The drawing and the information contained therein may not be reproduced in whole or in part without prior written or verbal permission of the designer or European Wrought Iron Works Ltd..
2. Drawings are not to be scaled for construction. All existing site conditions and dimensions required to perform the work are to be verified and any discrepancies are to be reported to the designer & European Wrought Iron Works Ltd..
3. These drawings are not to be used for construction unless noted below as "Issued for Construction"
4. All work to be carried out in conformance with the Code and Bylaws of the authorities having jurisdiction.
5. The Designer of these plans and specifications gives no warranty or representation to any party about the constructability of the item represented by them.

CONFIDENTIAL: NOT TO BE DISCLOSED OR REPRODUCED



European Collection
Gates

TOLERANCES
INCHES
UNLESS OTHERWISE NOTED
X.XXX" ±0.005"
X.XX" ±0.05"
X.X" ±0.25"
FRACTIONAL ±1/16"
ANGULAR ±1°

SCALE: NTS.
DATE DRAWN: Feb 2009
DRAWN BY: DCM

DO NOT
MODIFY OR
SCALE DRAWING

PROJECT TITLE:
DESIGN: P.D.
SHEET NO: 1

DRAWING & DESIGN REMAIN THE PROPERTY OF EUROPEAN WROUGHT IRON WORKS LTD.

FINISH: Custom
DRAWING NUMBER: EWIW-GD02
REV: 1-
A

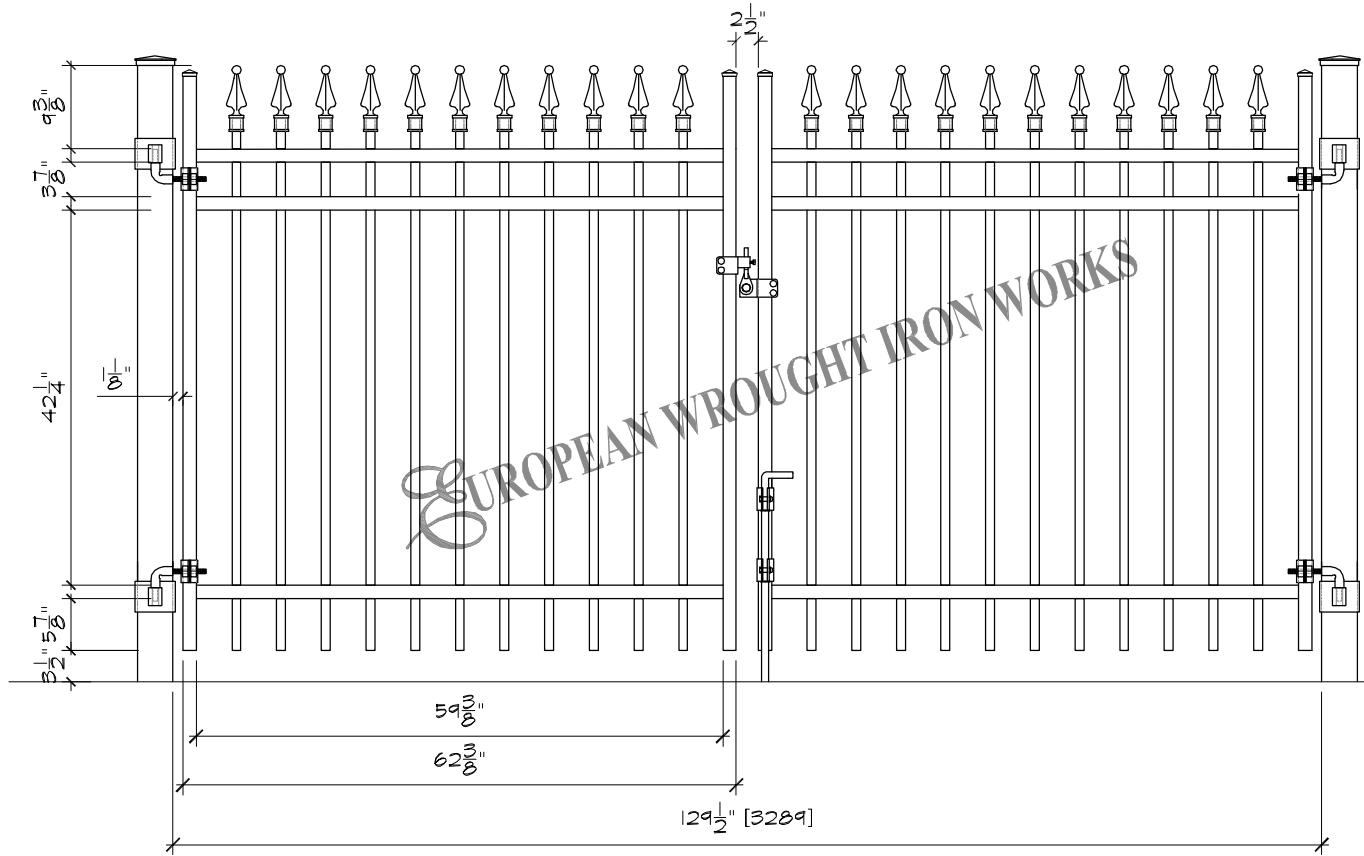

Specifications

POST, RAILS & PICKETS: Cold Formed Steel Tubing
Interior And Exterior Galvalume Coating
Chromate Conversion Coating
Electrostatically Applied
Thermally Bonded Polyester Powder Coating
Minimum Film Thickness 2.5 Mils

POSTS: 4" x 4" (100mm x 100mm)
.150 or .250 Wall

POST CAP: Pyramid, Ball or Spear

RAILS: 1-1/2" x 1-1/2" (38mm x 38mm) 14 Gauge

PICKETS: 1" x 1" (25mm x 25mm) 16 Gauge

FITTINGS: Stamp Forged Factory Finish. As Above

WELDS: Stainless Steel

STANDARD GATE WIDTH: 129-1/2" (3289mm)

AVAILABLE GATE HEIGHTS: 48" (1219mm)
(plus finial if applicable)
60" (1524mm)
72" (1828mm)

NOTE: Tamper Proof Nut Available For Brackets

COLOURS: Standard - High Gloss Black
Optional Colours - Brown, Forest Green & Matt Black
Custom Colours Available Upon Request.

The following note shall apply to all drawings and associated documents:
1. Copyright of this drawing and design is reserved by the Designer & European Wrought Iron Works Ltd. The drawing and all associated documents are an instrument of service by the Designer & European Wrought Iron Works Ltd. The drawing and the information contained therein may not be reproduced in whole or in part without prior written or verbal permission of the designer or European Wrought Iron Works Ltd.
2. Drawings are not to be scaled for construction. All existing site conditions and dimensions required to perform the work are to be verified and any discrepancies are to be reported to the designer & European Wrought Iron Works Ltd.
3. These drawings are not to be used for construction unless noted below as "Issued for Construction"
4. All work to be carried out in conformance with the Code and Bylaws of the authorities having jurisdiction.
5. The Designer of these plans and specifications gives no warranty or representation to any party about the constructability of the item represented by them.

CONFIDENTIAL: NOT TO BE DISCLOSED OR REPRODUCED



European Collection
Gates

TOLERANCES
INCHES
UNLESS OTHERWISE NOTED
X.XXX" ±0.005"
X.XX" ±0.05"
X.X" ±0.25"
FRACTIONAL ±1/16"
ANGULAR ±1°

SCALE: NTS.
DATE DRAWN: Feb 2009
DRAWN BY: DCM

DO NOT
MODIFY OR
SCALE DRAWING

PROJECT TITLE:
DESIGN: P.D.
SHEET NO: 1

DRAWING & DESIGN REMAIN THE PROPERTY OF EUROPEAN WROUGHT IRON WORKS LTD.

FINISH: Custom
DRAWING NUMBER: EWIW-GD03
REV: 1- A

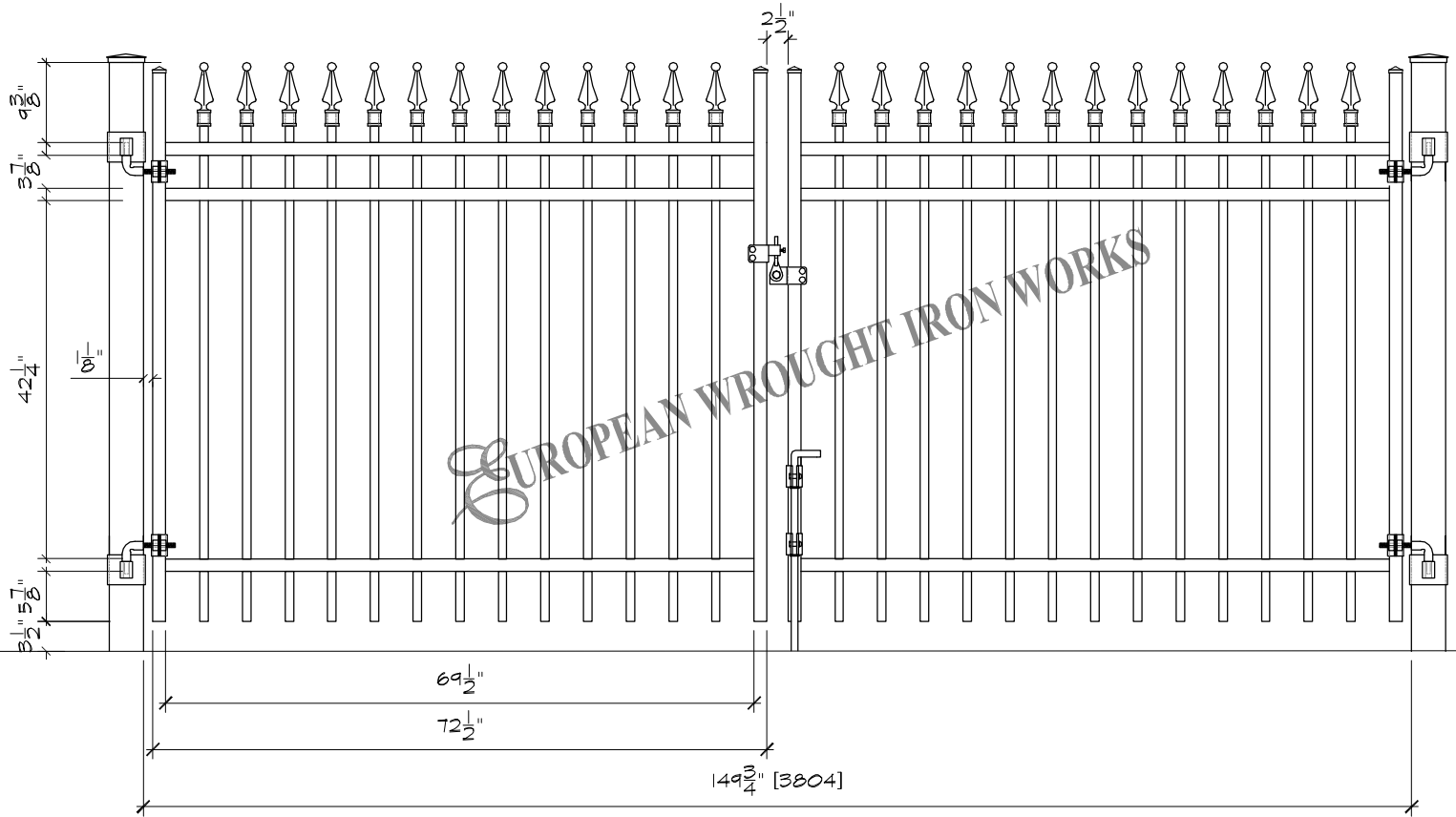

Specifications

POST, RAILS & PICKETS: Cold Formed Steel Tubing
Interior And Exterior Galvalume Coating
Chromate Conversion Coating
Electrostatically Applied
Thermally Bonded Polyester Powder Coating
Minimum Film Thickness 2.5 Mils

POSTS: 4" x 4" (100mm x 100mm)
.150 or .250 Wall

POST CAP: Pyramid, Ball or Spear

RAILS: 1-1/2" x 1-1/2" (38mm x 38mm) 14 Gauge

PICKETS: 1" x 1" (25mm x 25mm) 16 Gauge

FITTINGS: Stamp Forged Factory Finish. As Above

WELDS: Stainless Steel

STANDARD GATE WIDTH: 149-3/4" (3804mm)

AVAILABLE GATE HEIGHTS: 48" (1219mm)
(plus finial if applicable) 60" (1524mm)
72" (1828mm)

NOTE: Tamper Proof Nut Available For Brackets

COLOURS: Standard - High Gloss Black
Optional Colours - Brown, Forest Green & Matt Black

Custom Colours Available Upon Request.

The following note shall apply to all drawings and associated documents:

- Copyright of this drawing and design is reserved by the Designer & European Wrought Iron Works Ltd.. The drawing and all associated documents are an instrument of service by the Designer & European Wrought Iron Works Ltd.. The drawing and the information contained therein may not be reproduced in whole or in part without written or verbal permission of the designer or European Wrought Iron Works Ltd..
- Drawings are not to be scaled for construction. All existing site conditions and dimensions required to perform the work are to be verified and any discrepancies are to be reported to the designer & European Wrought Iron Works Ltd..
- These drawings are not to be used for construction unless noted below as "Issued for Construction"
- All work to be carried out in conformance with the Code and Bylaws of the authorities having jurisdiction.
- The Designer of these plans and specifications gives no warranty or representation to any party about the constructability of the item represented by them.

CONFIDENTIAL: NOT TO BE DISCLOSED OR REPRODUCED



European Collection
Gates

TOLERANCES
INCHES
UNLESS OTHERWISE NOTED
X.XXX" $\pm 0.005"$
X.XX" $\pm 0.05"$
X.X" $\pm 0.25"$
FRACTIONAL $\pm 1/16"$
ANGULAR $\pm 1^\circ$

SCALE: NTS.
DATE DRAWN: Feb 2009
DRAWN BY: DCM

DO NOT
MODIFY OR
SCALE DRAWING

PROJECT TITLE:

DRAWING & DESIGN REMAIN THE PROPERTY OF EUROPEAN WROUGHT IRON WORKS LTD.

DESIGN: P.D.
SHEET NO: 1

FINISH: Custom
DRAWING NUMBER: EWIW-GD04

REV 1- A

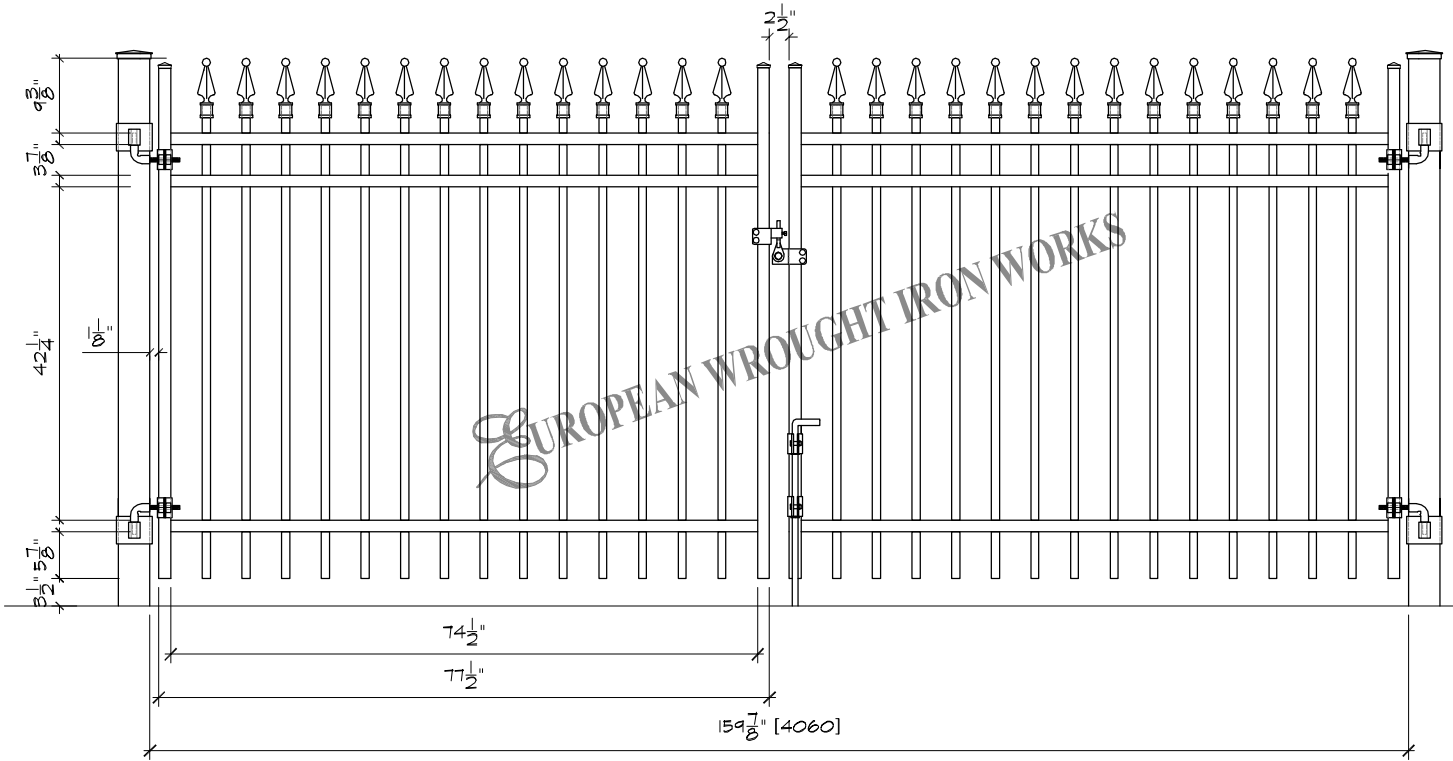

Specifications

POST, RAILS & PICKETS: Cold Formed Steel Tubing
Interior And Exterior Galvalume Coating
Chromate Conversion Coating
Electrostatically Applied
Thermally Bonded Polyester Powder Coating
Minimum Film Thickness 2.5 MILS

POSTS: 4" x 4" (100mm x 100mm)
.150 or .250 Wall

POST CAP: Pyramid, Ball or Spear

RAILS: 1-1/2" x 1-1/2" (38mm x 38mm) 14 Gauge

PICKETS: 1" x 1" (25mm x 25mm) 16 Gauge

FITTINGS: Stamp Forged Factory Finish. As Above

WELDS: Stainless Steel

STANDARD GATE WIDTH: 159-7/8" (4060mm)

AVAILABLE GATE HEIGHTS: 48" (1219mm)
(plus finial if applicable)
60" (1524mm)
72" (1828mm)

NOTE: Tamper Proof Nut Available For Brackets

COLOURS: Standard - High Gloss Black
Optional Colours - Brown, Forest Green & Matt Black

Custom Colours Available Upon Request.

The following note shall apply to all drawings and associated documents:

1. Copyright of this drawing and design is reserved by the Designer & European Wrought Iron Works Ltd. The drawing and all associated documents are an instrument of service by the Designer & European Wrought Iron Works Ltd. The drawing and the information contained therein may not be reproduced in whole or in part without prior written or verbal permission of the designer or European Wrought Iron Works Ltd.

2. Drawings are not to be scaled for construction. All existing site conditions and dimensions required to perform the work are to be verified and any discrepancies are to be reported to the designer & European Wrought Iron Works Ltd.

3. These drawings are not to be used for construction unless noted below as "Issued for Construction"

4. All work to be carried out in conformance with the Code and Bylaws of the authorities having jurisdiction.

5. The Designer of these plans and specifications gives no warranty or representation to any party about the constructability of the item represented by them.

CONFIDENTIAL: NOT TO BE DISCLOSED OR REPRODUCED



European Collection
Gates

TOLERANCES
INCHES
UNLESS OTHERWISE NOTED
X.XXX" ±0.005"
X.XX" ±0.05"
X.X" ±0.25"
FRACTIONAL ±1/16"
ANGULAR ±1°

SCALE: NTS.
DATE DRAWN: Feb 2009
DRAWN BY: DCM

DO NOT
MODIFY OR
SCALE DRAWING

PROJECT TITLE:

DRAWING & DESIGN REMAIN THE PROPERTY OF EUROPEAN WROUGHT IRON WORKS LTD.

DESIGN: P.D.
SHEET NO: 1

FINISH: Custom

DRAWING NUMBER: EWIW-GD05

REV 1- A

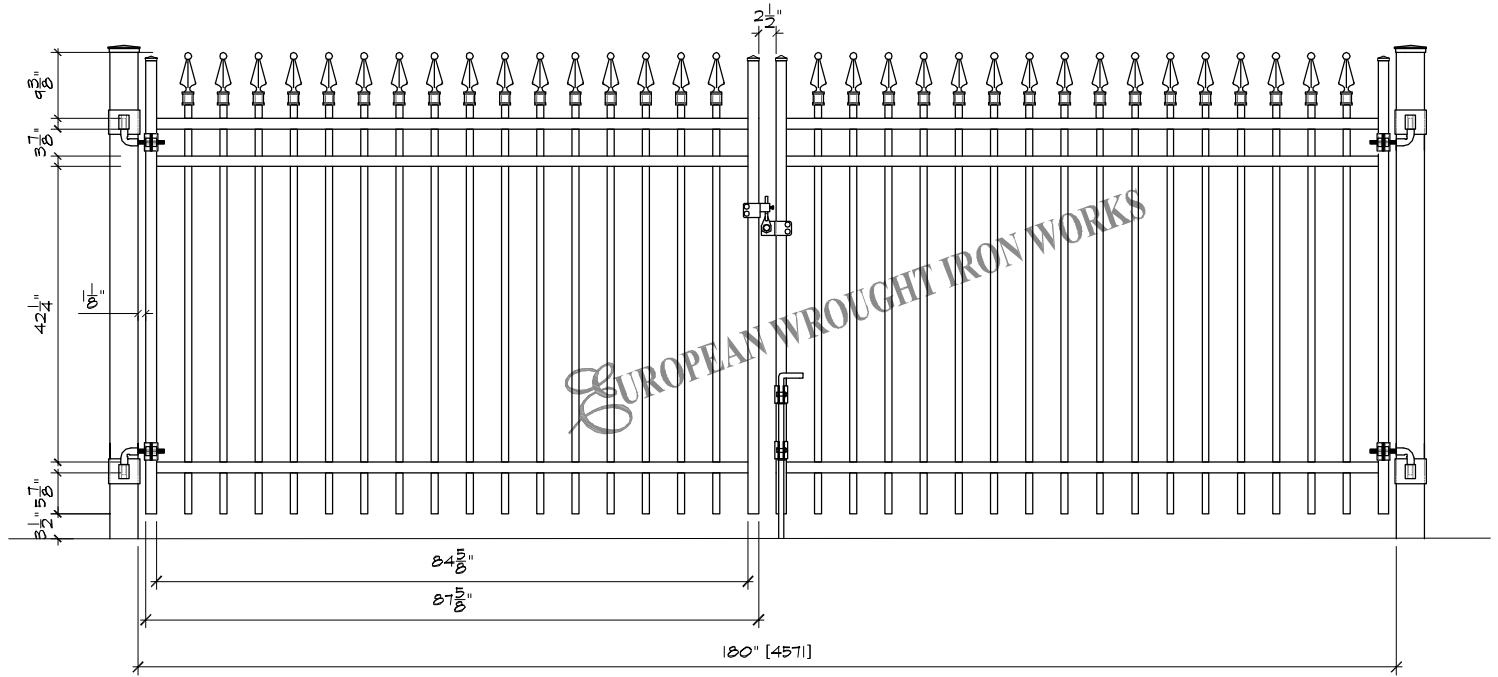

Specifications

POST, RAILS & PICKETS: Cold Formed Steel Tubing
Interior And Exterior Galvalume Coating
Chromate Conversion Coating
Electrostatically Applied
Thermally Bonded Polyester Powder Coating
Minimum Film Thickness 2.5 Mils

POSTS: 4" x 4" (100mm x 100mm)
.150 or .250 Wall

POST CAP: Pyramid, Ball or Spear

RAILS: 1-1/2" x 1-1/2" (38mm x 38mm) 14 Gauge

PICKETS: 1" x 1" (25mm x 25mm) 16 Gauge

FITTINGS: Stamp Forged Factory Finish. As Above

WELDS: Stainless Steel

STANDARD GATE WIDTH: 180" (4571mm)

AVAILABLE GATE HEIGHTS: 48" (1219mm)
(plus finial if applicable)
60" (1524mm)
72" (1828mm)

NOTE: Tamper Proof Nut Available For Brackets

COLOURS: Standard - High Gloss Black
Optional Colours - Brown, Forest Green & Matt Black

Custom Colours Available Upon Request.

The following note shall apply to all drawings and associated documents:

1. Copyright of this drawing and design is reserved by the Designer & European Wrought Iron Works Ltd. The drawing and all associated documents are an instrument of service by the Designer & European Wrought Iron Works Ltd. The drawing and the information contained therein may not be reproduced in whole or in part without prior written or verbal permission of the designer or European Wrought Iron Works Ltd.

2. Drawings are not to be scaled for construction. All existing site conditions and dimensions required to perform the work are to be verified and any discrepancies are to be reported to the designer & European Wrought Iron Works Ltd.

3. These drawings are not to be used for construction unless noted below as "Issued for Construction"

4. All work to be carried out in conformance with the Code and Bylaws of the authorities having jurisdiction.

5. The Designer of these plans and specifications gives no warranty or representation to any party about the constructability of the item represented by them.

CONFIDENTIAL: NOT TO BE DISCLOSED OR REPRODUCED



European Collection
Gates

TOLERANCES
INCHES
UNLESS OTHERWISE NOTED
X.XXX" ±0.005"
X.XX" ±0.05"
X.X" ±0.25"
FRACTIONAL ±1/16"
ANGULAR ±1°

SCALE: NTS.
DATE DRAWN: Feb 2009
DRAWN BY: DCM

DO NOT
MODIFY OR
SCALE DRAWING

PROJECT TITLE:
DESIGN: P.D.
SHEET NO: 1

DRAWING & DESIGN REMAIN THE PROPERTY OF EUROPEAN WROUGHT IRON WORKS LTD.

FINISH: Custom
DRAWING NUMBER: EWIW-GD06
REV 1-
A

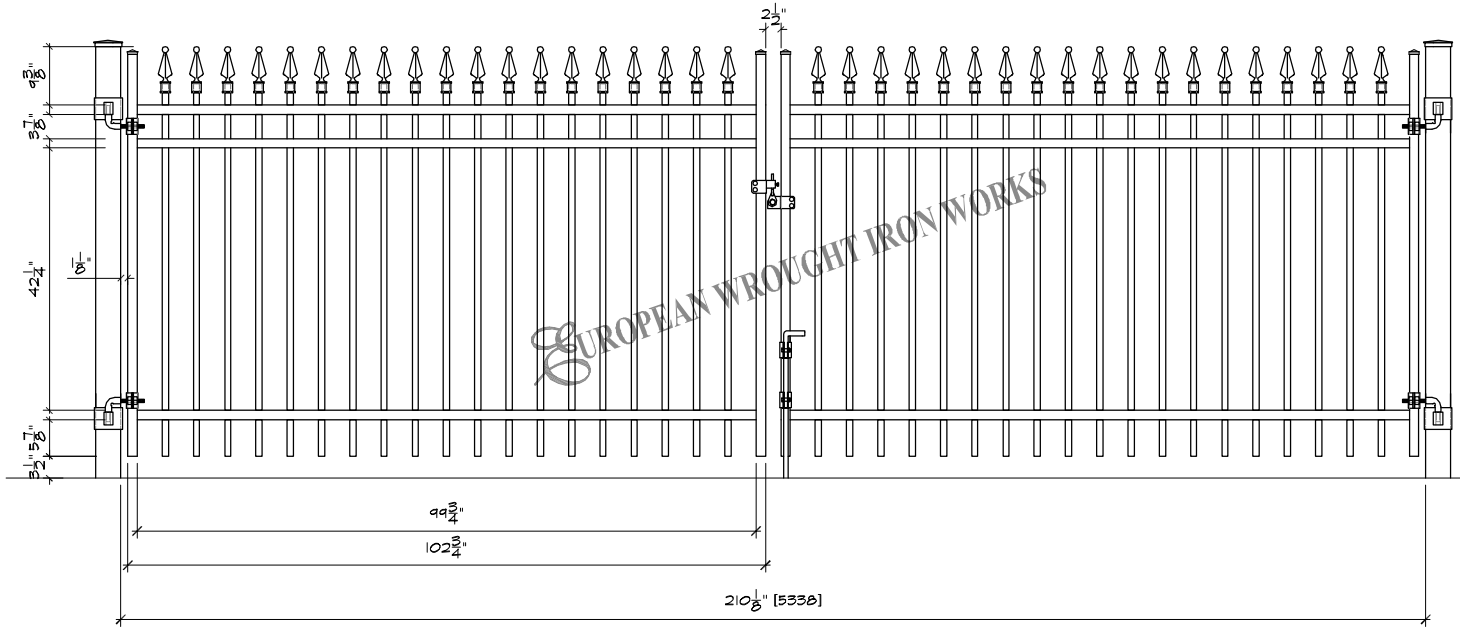

Specifications

POST, RAILS & PICKETS: Cold Formed Steel Tubing
Interior And Exterior Galvalume Coating
Chromate Conversion Coating
Electrostatically Applied
Thermally Bonded Polyester Powder Coating
Minimum Film Thickness 2.5 Mils

POSTS: 4" x 4" (100mm x 100mm)
.150 or .250 Wall

POST CAP: Pyramid, Ball or Spear

RAILS: 1-1/2" x 1-1/2" (38mm x 38mm) 14 Gauge

PICKETS: 1" x 1" (25mm x 25mm) 16 Gauge

FITTINGS: Stamp Forged Factory Finish. As Above

WELDS: Stainless Steel

STANDARD GATE WIDTH: 210-1/8" (5338mm)

AVAILABLE GATE HEIGHTS: 48" (1219mm)
(plus finial if applicable)
60" (1524mm)
72" (1828mm)

NOTE: Tamper Proof Nut Available For Brackets

COLOURS: Standard - High Gloss Black
Optional Colours - Brown, Forest Green & Matt Black

Custom Colours Available Upon Request.

The following note shall apply to all drawings and associated documents:

- Copyright of this drawing and design is reserved by the Designer & European Wrought Iron Works Ltd. The drawing and all associated documents are an instrument of service by the Designer & European Wrought Iron Works Ltd. The drawing and the information contained therein may not be reproduced in whole or in part without prior written or verbal permission of the designer or European Wrought Iron Works Ltd.
- Drawings are not to be scaled for construction. All existing site conditions and dimensions required to perform the work are to be verified and any discrepancies are to be reported to the designer & European Wrought Iron Works Ltd.
- These drawings are not to be used for construction unless noted below as "Issued for Construction"
- All work to be carried out in conformance with the Code and Bylaws of the authorities having jurisdiction.
- The Designer of these plans and specifications gives no warranty or representation to any party about the constructability of the item represented by them.

CONFIDENTIAL: NOT TO BE DISCLOSED OR REPRODUCED

EUROPEAN
WROUGHT IRON WORKS

TITLE:
European Collection
Gates

TOLERANCES
INCHES
UNLESS OTHERWISE NOTED
X.XXX" ±0.005"
X.XX" ±0.05"
X.X" ±0.25"
FRACTIONAL ±1/16"
ANGULAR ±1°

SCALE: NTS.
DATE DRAWN: Feb 2009
DRAWN BY: DCM

DO NOT
MODIFY OR
SCALE DRAWING

DRAWING & DESIGN REMAIN THE PROPERTY OF EUROPEAN WROUGHT IRON WORKS LTD.

PROJECT TITLE:

DESIGN: P.D.
SHEET NO: 1

FINISH: Custom

DRAWING NUMBER: EWIW-GD07

REV 1- A

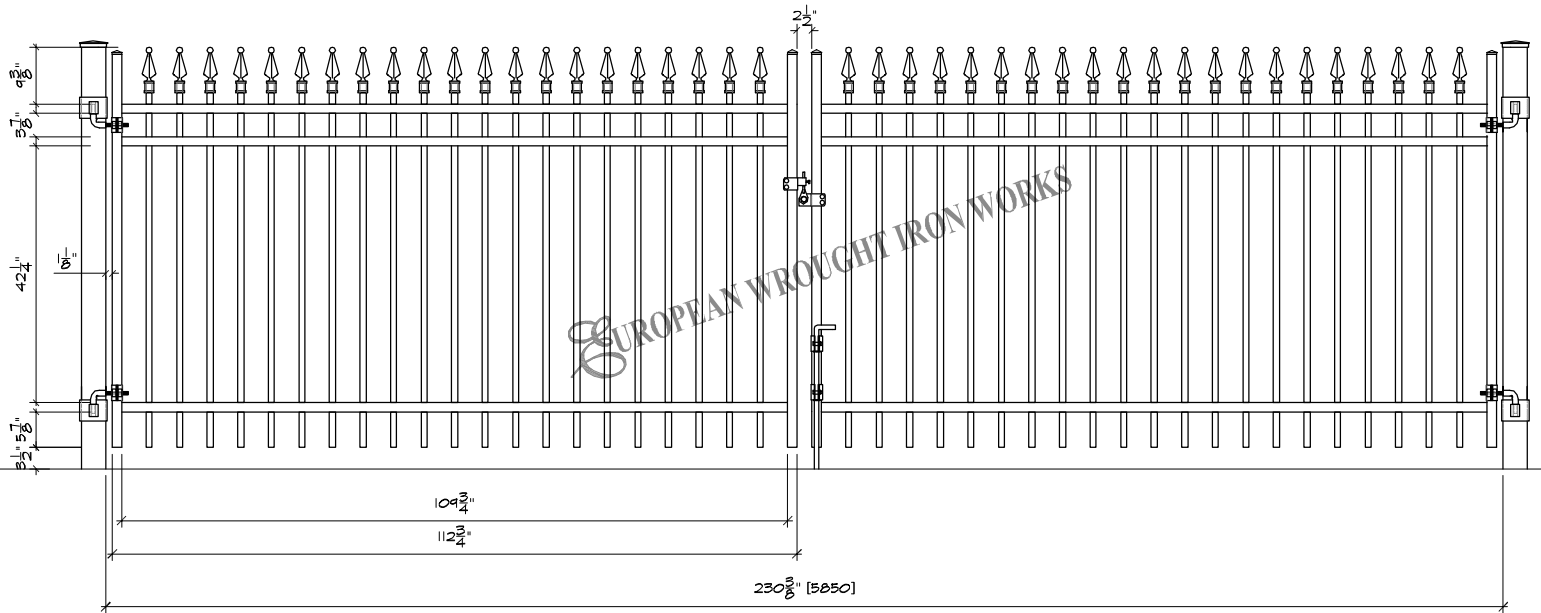

Specifications

POST, RAILS & PICKETS: Cold Formed Steel Tubing
Interior And Exterior Galvalume Coating
Chromate Conversion Coating
Electrostatically Applied
Thermally Bonded Polyester Powder Coating
Minimum Film Thickness 2.5 Mils

POSTS: 4" x 4" (100mm x 100mm)
.150 or .250 Wall

POST CAP: Pyramid, Ball or Spear

RAILS: 1-1/2" x 1-1/2" (38mm x 38mm) 14 Gauge

PICKETS: 1" x 1" (25mm x 25mm) 16 Gauge

FITTINGS: Stamp Forged Factory Finish. As Above

WELDS: Stainless Steel

STANDARD GATE WIDTH: 230-3/8" (5850mm)

AVAILABLE GATE HEIGHTS: 48" (1219mm)
(plus finial if applicable)
60" (1524mm)
72" (1828mm)

NOTE: Tamper Proof Nut Available For Brackets

COLOURS: Standard - High Gloss Black
Optional Colours - Brown, Forest Green & Matt Black

Custom Colours Available Upon Request.

The following note shall apply to all drawings and associated documents:
1. Copyright of this drawing and design is reserved by the Designer & European Wrought Iron Works Ltd. The drawing and all associated documents are an instrument of service by the Designer & European Wrought Iron Works Ltd. The drawing and the information contained therein may not be reproduced in whole or in part without prior written or verbal permission of the designer or European Wrought Iron Works Ltd.
2. Drawings are not to be scaled for construction. All existing site conditions and dimensions required to perform the work are to be verified and any discrepancies are to be reported to the designer & European Wrought Iron Works Ltd.
3. These drawings are not to be used for construction unless noted below as "Issued for Construction"
4. All work to be carried out in conformance with the Code and Bylaws of the authorities having jurisdiction.
5. The Designer of these plans and specifications gives no warranty or representation to any party about the constructability of the item represented by them.



TITLE:
European Collection
Gates

TOLERANCES
INCHES
UNLESS OTHERWISE NOTED
X.XXX" ±0.005"
X.XX" ±0.05"
X.X" ±0.25"
FRACTIONAL ±1/16"
ANGULAR ±1°

SCALE: NTS.

DATE DRAWN: Feb 2009

DRAWN BY: DCM

DO NOT MODIFY OR SCALE DRAWING

PROJECT TITLE:

DESIGN: P.D.

SHEET NO: 1

DRAWING & DESIGN REMAIN THE PROPERTY OF EUROPEAN WROUGHT IRON WORKS LTD.

FINISH: Custom

DRAWING NUMBER: EWIW-GD08

REV 1- A

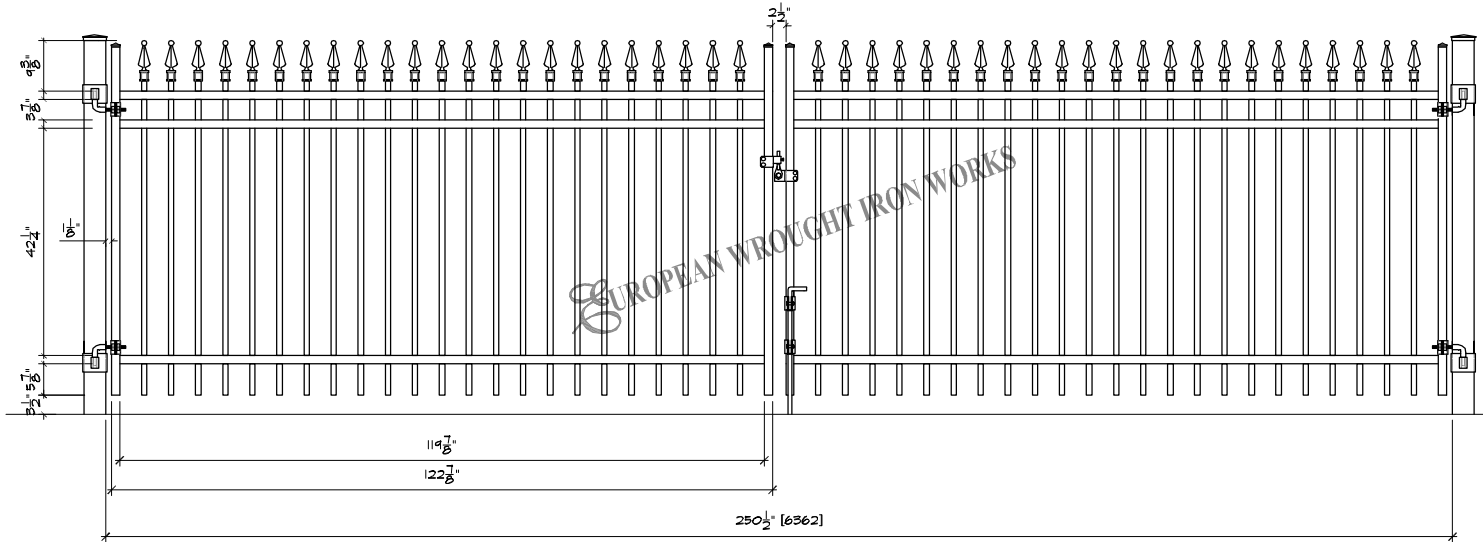

Specifications

POST, RAILS & PICKETS: Cold Formed Steel Tubing
Interior And Exterior Galvalume Coating
Chromate Conversion Coating
Electrostatically Applied
Thermally Bonded Polyester Powder Coating
Minimum Film Thickness 2.5 Mils

POSTS: 4" x 4" (100mm x 100mm)
.150 or .250 Wall

POST CAP: Pyramid, Ball or Spear

RAILS: 1-1/2" x 1-1/2" (38mm x 38mm) 14 Gauge

PICKETS: 1" x 1" (25mm x 25mm) 16 Gauge

FITTINGS: Stamp Forged Factory Finish. As Above

WELDS: Stainless Steel

STANDARD GATE WIDTH: 250-1/2" (6362mm)

AVAILABLE GATE HEIGHTS: 48" (1219mm)
(plus finial if applicable)
60" (1524mm)
72" (1828mm)

NOTE: Tamper Proof Nut Available For Brackets

COLOURS: Standard - High Gloss Black
Optional Colours - Brown, Forest Green & Matt Black

Custom Colours Available Upon Request.

The following note shall apply to all drawings and associated documents:

- Copyright of this drawing and design is reserved by the Designer & European Wrought Iron Works Ltd. The drawing and all associated documents are an instrument of service by the Designer & European Wrought Iron Works Ltd. The drawing and the information contained therein may not be reproduced in whole or in part without prior written or verbal permission of the designer or European Wrought Iron Works Ltd.
- Drawings are not to be scaled for construction. All existing site conditions and dimensions required to perform the work are to be verified and any discrepancies are to be reported to the designer & European Wrought Iron Works Ltd.
- These drawings are not to be used for construction unless noted below as "Issued for Construction"
- All work to be carried out in conformance with the Code and Bylaws of the authorities having jurisdiction.
- The Designer of these plans and specifications gives no warranty or representation to any party about the constructability of the item represented by them.

CONFIDENTIAL: NOT TO BE DISCLOSED OR REPRODUCED



European Collection
Gates

TOLERANCES
INCHES
UNLESS OTHERWISE NOTED
X.XXX" ±0.005"
X.XX" ±0.05"
X.X" ±0.25"
FRACTIONAL ±1/16"
ANGULAR ±1°

SCALE: NTS.
DATE DRAWN: Feb 2009
DRAWN BY: DCM

DO NOT
MODIFY OR
SCALE DRAWING

DRAWING & DESIGN REMAIN THE PROPERTY OF EUROPEAN WROUGHT IRON WORKS LTD.

PROJECT TITLE:

DESIGN: P.D.
SHEET NO: 1

FINISH: Custom

DRAWING NUMBER: EWIW-GD09

REV 1- A